

Compact Carrier

EK404

Operator's Manual

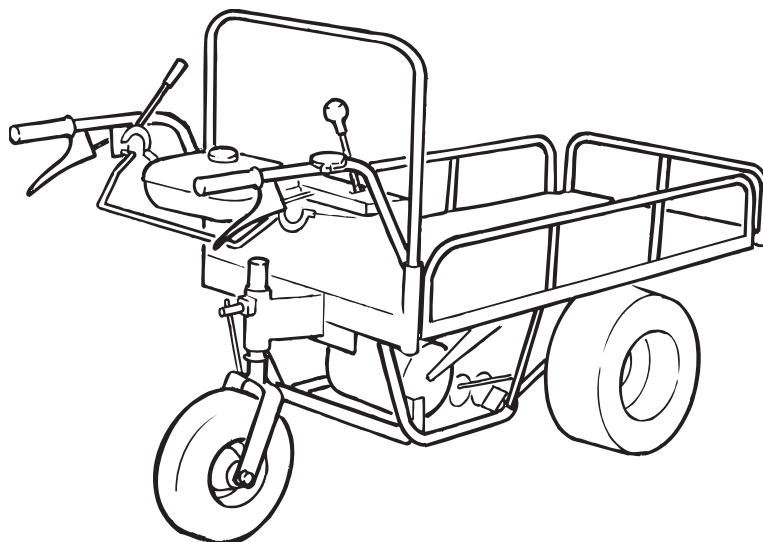

⚠ WARNING!

Read this manual completely before operating or maintaining this machine. Failure to follow safety precautions could result in serious injury or death. Keep this manual for future reference by you and by all those who operate and maintain this machine.

CHIKUSUI CANYCOM, INC.

<http://www.canycom.co.jp/>

CHIKUSUI CANYCOM, INC.
90-1 Fukumasu, Yoshii-machi,
Ukiha-shi, Fukuoka, Japan 839-1396

Sales Headquarters (International) TEL +81-(0)943-75-2195
FAX +81-(0)943-75-4396

Authorized Dealer

Notice to Users and Maintenance Personnel

Thank you for purchasing this machine.

This manual provides information needed for safe and effective use of this machine to those who operate or maintain this machine. Make sure to read and understand this manual thoroughly before operating this product. Also make sure to read the separate operator's manual for the engine.

WARNING!

- **This machine can be very dangerous if the safety precautions in this manual and on labels attached to this machine are not followed. Read and understand this manual and safety labels on machine thoroughly before using this machine. Always follow the instructions and safety precautions, or serious injury or death could result.**
- **This machine should only be used for its intended purpose: hauling materials. Any other use could be dangerous.**
- **This machine may not be operated on public road or what is considered to be public road. It is the sole responsibility of the operator to consult the local regulations.**
- **Do not modify this machine, or do not operate this machine with safety covers removed or open. A serious accident could result.**

CAUTION!

- **Store this manual in a safe, accessible place for easy reference.**
-



Notice to Owner

CAUTION!

- Be sure that everyone who uses this machine, including those who rent or lease this machine, receives a copy of this Operator's Manual and understands the importance of reading and following the information in this manual.

Warning Terms Used in this Manual

In this manual, the following four warning terms are used to signal the four levels of hazard (or seriousness of possible accidents). Read and understand what they mean and always follow the instructions in this manual.

Warning Term	Definition
 DANGER!	Indicates an imminently hazardous situation which will result in death or serious injury if the user does not follow the procedures or the instructions.
 WARNING!	Indicates a potentially hazardous situation which could result in death or serious injury if the user does not follow the procedures or the instructions.
 CAUTION!	Indicates a potentially hazardous situation which could result in minor to moderate injury or damage to the machine if the user does not follow the procedures or the instructions.
<u>NOTE</u>	Indicates important information which needs particular attention.

Warranty and After-Sales Service

Warranty

CHIKUSUI CANYCOM, INC. provides a warranty through your local CANYCOM dealer.

After-Sales Service

Consult your local CANYCOM dealer or our company's sales department regarding service orders or any questions or problems that may arise when using this machine. Please make sure to have the product name, serial number, and the make and type of engine handy at the time of contact. The model and serial number can be found on the model label as shown below, and the make and type of engine can be found in Chapter 3 "**Specifications**" of this manual (Page 10).

Position of Model Label

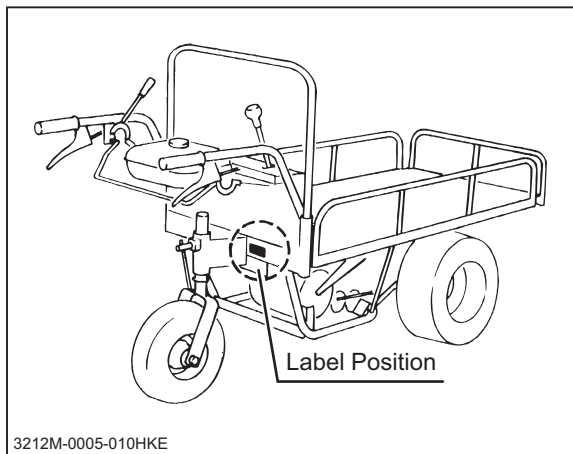

Model Label



Availability of Spare Parts

The replacement or repair parts for this product shall remain available for seven years after the production of this type of machine is discontinued.

Contents

1. Safety	1
Safety Labels	1
Safety Precautions	2
Training	2
Preparation	3
Operation	3
Servicing	7
2. Controls and Components	8
Name and Function of Controls	8
3. Specifications	10
Product Specifications	10
Contents of the Tool Bag	11
4. Operation	12
Preparation	12
Pre-start up Inspection	12
Checking and Filling Fuel	12
Driving	13
Starting	13
Driving	16
Parking	20
5. Maintenance	22
Maintenance Schedule	22
Engine	22
Chassis	23
List of Fluids and Lubricants	25
Lubrication	25
List of Consumables and Spares	26

Engine	27
Engine Oil	27
Air Cleaner Element	28
Spark Plug	29
Fuel Filter	29
Drive Train	30
Tires	30
Transmission Oil	31
Drive Belt	32
Parking Brake	33
Side Clutch	34
After Use Care	35
After Normal Use	35
After Cold Weather Use	35
Storage	36

6. Troubleshooting	37
---------------------------	-----------

Troubleshooting	37
---------------------------	----

7. Transporting	40
------------------------	-----------

Hauling	40
Loading and Unloading	40

Warranty

Warranty Certificate is attached at the end of this manual.

- * Have the warranty certificate signed and sealed after you have received and fully understood the instructions for handling this machine and received the receipt.

Appendix

- Operator's Manual for the Engine
 - * Be sure to read and understand it together with this manual .
-

Safety Labels



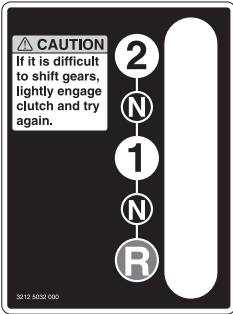

The safety labels shown below are attached to the machine. See the illustration for the location and the content of each label on the machine.

- **Locate all the warning labels attached to this machine. Read and follow the instructions and precautions in them. Failure to do so could result in serious injury or death to the operator or bystanders.**
- **Keep the labels clean and legible. Do not use solvents or gasoline to clean the labels.**
- **Replace these labels immediately if they have been removed, have fallen off or become illegible. Use the part number, on the label or shown in this manual, to order a replacement label from your CANYCOM representative.**

① 3212 5032 000



② 3212 5036 000

⚠ DANGER	⚠ DANGER	⚠ DANGER	⚠ WARNING	⚠ WARNING
				
Shift gears positively. If transmission jumps out of gear on an incline, the machine can run out of control, causing injuries or death.	Load evenly and securely. Unsecured or loose load can fall or throw the machine offbalance.	When driving on an incline, drive carefully. A small bump or sudden braking can tip over the machine and cause serious injuries or death.	Do not operate this machine with safety covers removed. Hands, hair, other body parts, or clothes can be caught, resulting in injuries.	Read the operator's manual thoroughly before operating or servicing this machine.

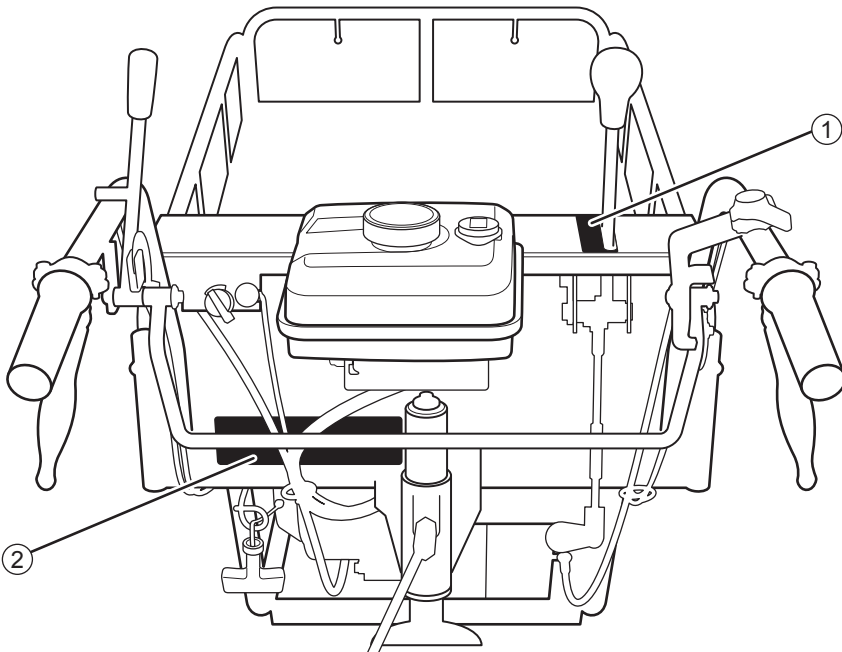

3212M-0104-011HKE

Safety Precautions

This section contains safety precautions to follow when operating and maintaining this machine. Read and understand the precautions in this section as well as throughout this manual and follow them when operating or maintaining the machine. Failure to follow safety precautions could result in property damage, serious injury or death to the operator or bystanders.

Training

All operators should be familiar with the following issues when using this machine. In case the machine is used by a hired worker or is rented, the employer or renter shall give practical instructions covering the following issues to the user.

- **It is essential to familiarize yourself with the controls, safety labels and proper use of the machine.**
- **Never allow people unfamiliar with these instructions to operate or service the machine. Do not let anyone under 18 years of age to operate this machine. Local regulations may restrict the minimum age for operating a machine. Consult your local authority.**
- **This machine is not intended to carry a person. Do not carry a person.**
- **The operator is responsible for the accidents or hazards caused to other people or their property.**
- **Always keep in mind that care and concentration is required when working with a load-carrying machine.**
- **Loss of control on a slope cannot be regained by the application of brake. Main reasons for the loss of control are:**
 - **insufficient grip of tires.**
 - **excessive speed.**
 - **misjudging of the ground conditions, especially inclination.**
 - **excessive load.**
 - **incorrect distribution of load.**

Preparation

- **Always wear protective footwear, long trousers, hardhat, safety glasses and ear protection when operating or servicing a machine. Proper clothing will minimize the chance of injury. Do not operate a machine if you have long hair, loose clothing, or jewelry; all of which can get tangled in moving parts. Do not operate a machine barefoot or with open sandals.**
- **Prepare beforehand the working rules and procedures such as signaling and traffic control for the work place. Following such rules will reduce the risk of accidents.**
- **Perform daily pre-startup inspection (see Preparation, page 12) before starting a machine. Repair or replace damaged parts before starting a machine.**
- **Fuel is highly flammable. See Checking and Filling Fuel, page 12, for important safety information on handling fuel; keep fire and spark away. Stop the engine when refueling.**
- **Never handle oil or grease, service engine, or recharge battery in the presence of fire or spark.**

Operation

This machine is intended for carrying grains, produce, dirt and similar materials. Carrying other objects may damage the machine.

The stability of a machine is affected by speed, rate of steering, terrain and load. Always pay close attention to these factors or loss of control or tipping over could occur, resulting in property damage, serious injury or death.

General Driving

- Do not operate the engine in a confined space where dangerous carbon monoxide fumes can accumulate.
- Do not touch the engine, muffler or exhaust pipe while the engine is running or soon after it has stopped. These areas will be very hot and can cause burns.
- Do not operate the machine under the influence of alcohol or drugs. Do not operate the machine when you are tired, ill, or not fit to operate a machine.
- Before starting the engine and moving the machine, scan around your surroundings and make sure all persons and other vehicles are a safe distance away from the machine.
- Never operate on a terrain that you are not comfortable with. Avoid the terrain that is so rough, slippery or loose that you feel like the machine could tip over.
- Always check for obstacles before operating on a new terrain.
- Always travel slowly and use extra caution when operating on an unfamiliar terrain. Be alert when traveling on a changing terrain.
- Drive at a safe speed, taking into account the surface gradient, surface conditions and load.
- Do not make sudden maneuvers. Sudden start, stop, or turn can make the machine lose control and could cause a tip over. Be especially cautious when traveling on soft or wet ground.
- On a slippery surface, travel slowly and exercise caution to reduce the chance of skidding or sliding out of control. Never operate on ice.
- Always make certain that there is no obstacle or person behind the machine when backing up. Make certain that it is safe to back up, then move slowly and avoid sharp turns.

- To reduce the risk of tipping over, pay special attention when encountering an obstacle or a slope, or when braking on a slope or during a turn. See Driving on a slope on below.
- Never attempt to drive over a large obstacle such as rock or fallen tree.
- Do not operate the machine near the edge of a cliff, an overhang or a landslide area.
- Use an observer to help direct the machine when visibility is poor, terrain is rugged or hilly, or maneuvering room is limited. An observer should be able to see the machine and its immediate surroundings, and should give pre-arranged signals to direct the operator.

Driving on a Slope

- Driving on a slope can be dangerous. It can result in tip over and cause serious injury or death. Always follow proper procedures for driving on a slope as described in this manual.
- When carrying no load, do NOT use this machine on a slope steeper than 15 degrees. When carrying a load, observe the load limit according to the inclination (see Loading and Driving with the Load, page 6). Do not perform lifting or dumping on a slope.
- Driving on a slope in a wrong manner can cause loss of control or vehicle tip over. Check the terrain carefully before attempting to drive on a slope.
- Never drive on a slope that you are not comfortable with. Avoid the slope that is so rough, slippery, or loose that you feel like the machine could tip over.
- When driving down a slope, stop and shift to lowest gear. Go down at a reduced speed. Use engine speed to help keep the machine speed low.

- When driving up a slope, proceed at a steady rate of speed and throttle position.
- Never move the throttle lever or operate the side clutch suddenly.
- Drive straight up or down a slope. Avoid turning on a slope. Avoid driving the machine across a slope.
- If the engine stalls or loses traction during a climb and cannot make it to the top of a slope, do not try to turn the machine around. Carefully back down slowly, straight down a slope.
- When going over the top of a slope, go slow; an obstacle, a sharp drop, or another vehicle or person could be on the other side of the crest.
- Without a load, drive the machine backwards up a slope (operator's handle toward the top) when climbing, and drive it forward when going down a slope.
- With a load, drive the machine forward up a slope (operator's handle away from the top) when climbing, and drive it backwards when going down a slope. Be especially cautious when operating on a slope with a load.

Loading and Driving with a Load

- The maximum payload for this machine is 250kg. Do not exceed this maximum payload under any circumstance.
- Do not operate this product on a slope steeper than 15 degrees. Do not carry more than 150kg when operating on a slope between 10 and 15 degrees.
- Place a load in the bed so that the weight is evenly distributed. When carrying a load, strap it to the bed to prevent it from shifting. Ensure that the load does not obstruct the operator's field of view.
- When carrying a load, drive at a reduced speed. Allow greater distance for braking.
- Before crossing a bridge or an overpass, make certain that the total combined weight of the machine, load and operator is within the stated weight limit of the bridge or the overpass. Then, proceed carefully and at a constant speed.

Parking

- Park the machine on a flat, level and stable surface. Do not park in a dangerous place. Never park the machine on a slope steeper than 15 degrees. Avoid parking on a slope less than 15 degrees. If parking on a slope less than 15 degrees is unavoidable, chock the drive wheels.
 - Without a load, park the machine with operator's handle uphill
 - With a load, park the machine with operator's handle downhill
 - Do not park sideways on a slope.
- Observe all the previous precautions for general driving, driving on a slope, and loading and driving with a load.
- Whenever you park the machine, disengage clutch and stop the engine.
- Gasoline is highly flammable and can be explosive. When parking the machine indoors, make certain that the building is well ventilated and that the machine is not close to any source of flame or spark, including appliances with pilot lights.

Servicing

- Do not service the machine when the engine is running. If it is absolutely necessary to run the engine while servicing, keep hands, feet, clothing and any part of the body away from any moving part, especially belts at the side of the engine.
- Do not operate the engine in a confined space where dangerous carbon monoxide fumes can accumulate.
- Check all fuel lines on a regular basis for fit and wear. Tighten or repair them as needed.
- Do not touch the engine, muffler, or exhaust pipe while the engine is running or soon after it has stopped. These areas will be very hot and can cause burns.
- The engine must be shut off before checking or adding oil.

2

Controls and Components

Name and Function of Controls

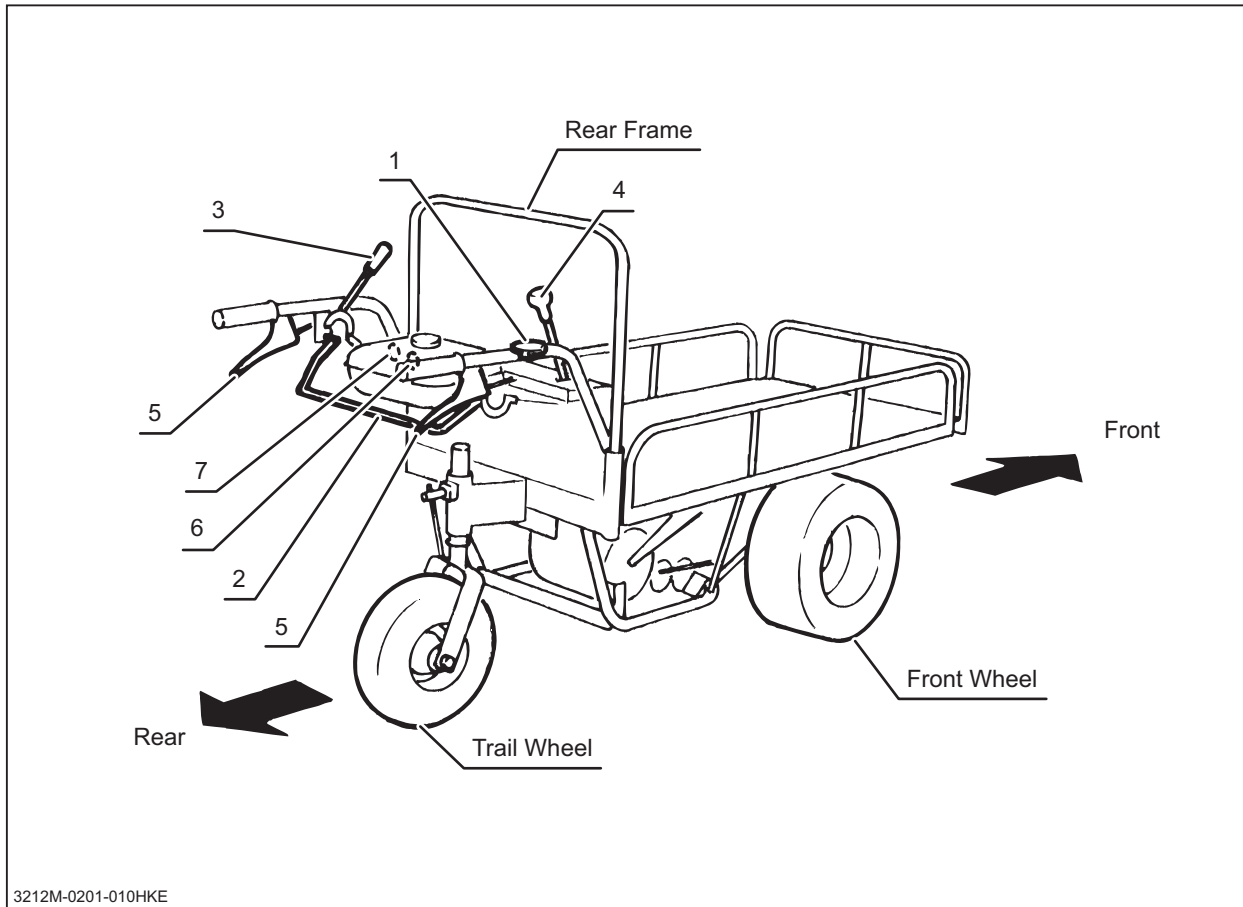

- 3212M-0201-010HKE
- 1 Throttle Lever** Throttle Lever is used to control engine speed.
 - 2 Drive Clutch Lever** Drive Clutch Lever is used to engage or disengage the drive clutch. Pull up the drive clutch lever to [Drive] to engage and push down the lever to [Stop] to disengage the drive clutch.
 - 3 Parking Brake Lever** Parking Brake Lever is used to park the machine firmly. Pushing the lever forward to [OFF] to disengage, pulling the lever toward to [ON] to engage parking brake.
 - 4 Shift Lever.** Shift Lever is used to shift gears. Move the drive clutch lever to [Stop] when you shift gears.

- 5 **Side Clutch Lever** Side Clutch Lever is used to steer the machine by engaging the side clutch. Grip the side clutch lever on the left to turn left and do the opposite to turn right. Be cautious when going down a slope because the machine may turn to the opposite direction. Gripping both clutch levers brake the front wheels.

- 6 **Choke knob**. Choke knob is used to help start the engine by closing the choke valve.

- 7 **Main Switch** Main Switch is used to start or stop the engine.

Product Specifications

⚠ CAUTION!

- Use this product properly after understanding its specifications thoroughly.

Model and Type		EK 404		
Machine Mass		kg	115	
Maximum Payload		kN (kgf)	2.45 (250)	
Dimensions	Overall Length	mm	1825	
	Overall Width	mm	675	
	Overall Height	mm	990	
	Wheel Base	mm	1020	
	Tread	mm	425	
	Ground Clearance	mm	145	
	Loading Deck Height	mm	485	
Loading Deck	Inside Dimensions	Length	mm	1255<1595>
		Width	mm	580<960>
		Height	mm	160
Engine	Model		Mitsubishi GB130	
	Type		Air-cooled 4-cycle gasoline, OHV	
	Cylinder (Bore×Stroke)		mm	62×42
	Displacement		cm ³	126
	Max. Output		kw(PS)/rpm	3.0 (4.2)/2000
	Rated Output		kw(PS)/rpm	2.3 (3.1)/1800
	Maximum Torque		N•m(kgf•m)/rpm	15.3 (1.56)
	Starter System			Recoil
	Fuel			Automotive Unleaded Gasoline
	Fuel Consumption		g/kW•h(g/PS•h)	313 (230)
	Fuel Tank Capacity		L	2.5
	Oil Capacity		L	0.5
	Ignition System			Contactless Magneto
Spark Plug			NGK BP6HS	

Model and Type			EK 404	
Performance	Speed	Forward 1st	km/h	2.9
		Forward 2nd	km/h	5.1
		Reverse 1st	km/h	3.0
	Minimum Turning Radius		m	1.1
Gradeability		Degrees	15 (unloaded)	
Transmissino Oil Capacity		L	1.0	
Drivetrain	Clutch		Belt Tension	
	Main Transmission		Gear Slide	
	Steering Mechanism		Dog Clutch	
	Brake		Internally Expanding	
	Tire	Front	mm	AGP 16 x 7.00 - 8 2PR
Rear		L	HC 3.50 - 5 2PR	

< > indicates when slide frames are extended.

*These specifications are subject to change without notice.

Contents of the Tool Bag

No.	Content	Quantitiy	Note
1	Operator's Manual	1	This Manual
2	Operator's Manual for the Engine	1	
3	Engine Service Tool	1	for Servicing the Engine

Preparation

Pre-start up Inspection

Always perform an inspection before use.

Refer to "**Maintenance Schedule**" (page 22) for the inspection schedule and procedure.

Checking and Filling Fuel

⚠ WARNING!

- Keep fire and spark away when handling fuel.
- Always stop the engine before refueling.
- Keep the fuel level below the bottom of the fuel filter inside the fuel filler. Do not overfill fuel so that fuel will not overflow. In case fuel is spilt, wipe out immediately.

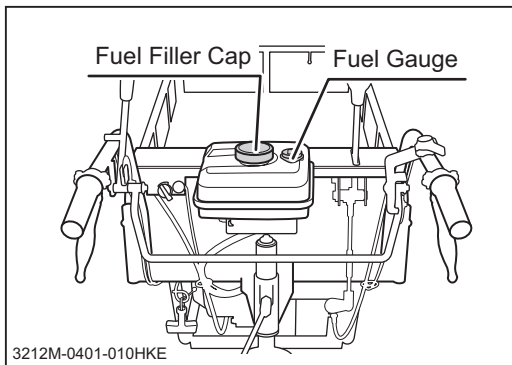

1. Check the fuel gauge. If fuel level is low, fill fuel.
2. Open the fuel filler cap and fill fuel.
3. Close the fuel filler cap securely.

NOTE

- Fuel : Automotive Unleaded Gasoline
- Fuel Tank Capacity: 2.5L

Driving

Starting

⚠ WARNING!

- Always start and run the engine in a well ventilated place.
- Always make certain of the safety of your surroundings when starting the engine.

⚠ CAUTION!

- Do not turn the starter when the engine is running. The starter motor and/or the engine may be damaged.
- Do not use this machine in temperatures above 40°C or below -15°C. This machine cannot perform adequately in these temperature ranges. Using this machine under such conditions may result in an accident or cause damage to machine.
- In the winter or cold climate, warm up the engine thoroughly before driving the machine. A cold engine delivers poor performance, which may result in an accident. It also causes excessive wear.
- Do not use this machine in dusty places such as desert. Dust may clog air cleaner or enter the engine, which may result in loss of performance and an accident. It also causes excessive wear.
- Do not use this machine in the altitude above 1500m in its original configuration. This machine cannot perform adequately above that altitude. Using this machine under such conditions may result in an accident or cause damage to the machine. If you need to use this machine above that altitude, contact your CANYCOM representative.

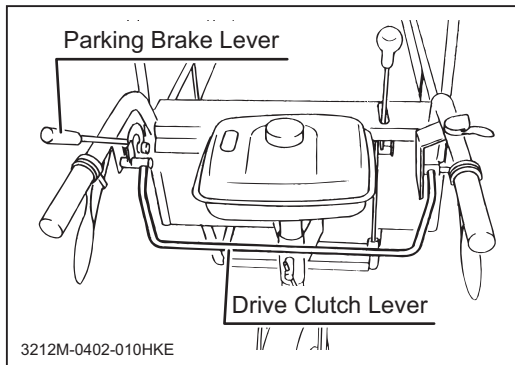

1. Make sure the drive clutch lever is in [Stop] position.

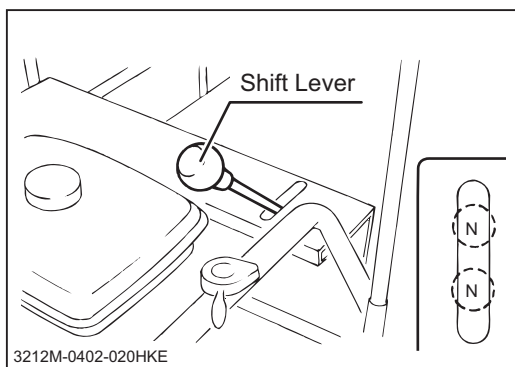

2. Make sure the shift lever is in [N (neutral)] position.

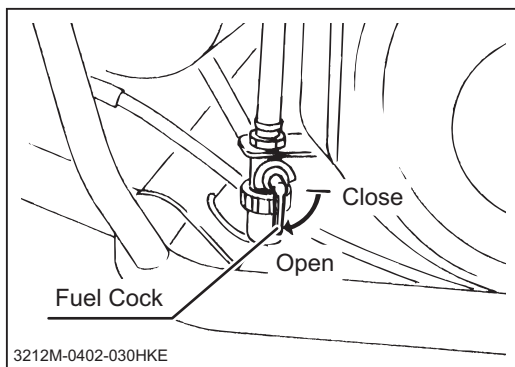

3. Open the fuel cock.

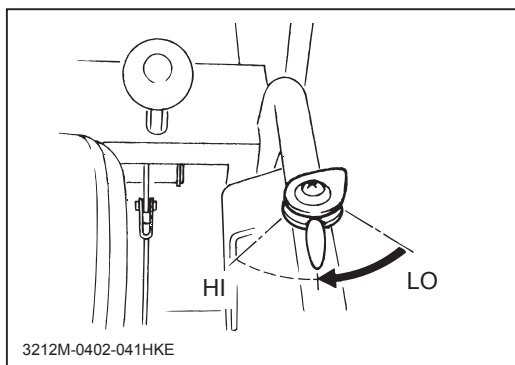

4. Move the throttle lever between [HI] and [LO].

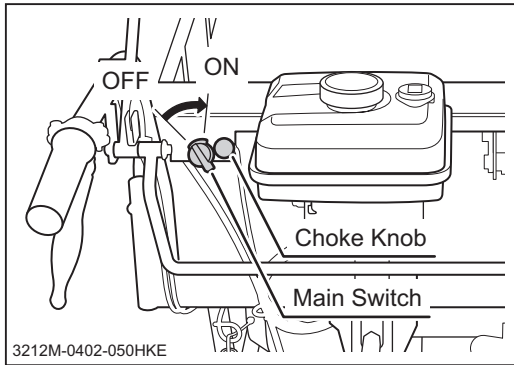

5. Turn the main switch [ON].
6. Pull the choke knob and close the choke valve.

NOTE

- Choke valve does not need to be closed when the engine is warm

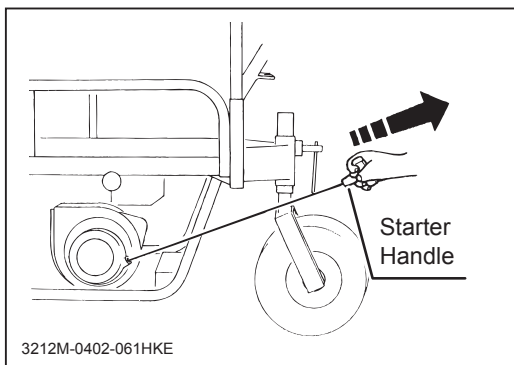

7. Hold the starter handle and pull it lightly until the rope gets tight. Then pull the handle rapidly.

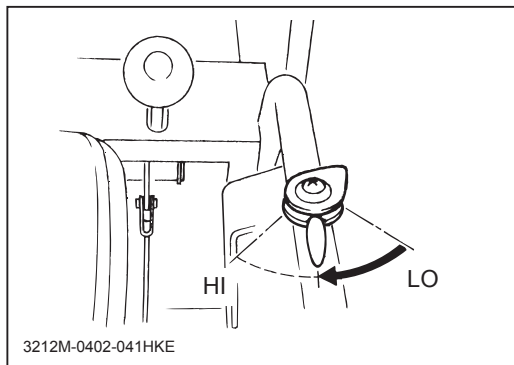

8. Release the starter handle when the engine starts.
9. Once the engine starts, return the throttle lever to [LO] position.

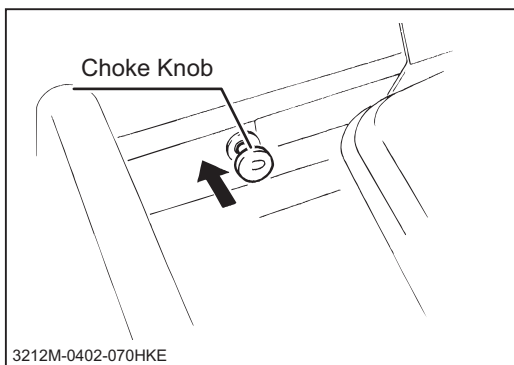

10. Move the choke knob back and warm up the engine for about 3 to 5 minutes.

NOTE

- Drive the machine gently in the first 40 to 50 hours of use after purchase for breaking-in.

Driving

⚠️ WARNING!

- Do not allow bystanders to come near the machine when driving.
- Always make certain of the safety of your surroundings before driving; start slow. Adjust speed according to the condition and gradient of the surface on which you are traveling.
- Do not make sudden start, acceleration, change of speed, change of direction, or stop. Do not turn at high speed. Avoid sudden maneuvers; this may cause the operator to be dragged or to be thrown, or the machine to tip over.
- Drive slowly when traveling on a slope. Operator can be dragged or thrown, or the machine can tip over.
- Be cautious when driving on the steep slope because the machine may move opposite to your operation depending on the pull force on the side clutch lever. Avoid turning on the steep slope.
- Use an observer to help direct the machine when the visibility is poor, terrain is rugged or hilly, or maneuvering room is limited. The observer should be able to see the machine and its immediate surroundings, and should give pre-arranged signals to direct the operator.
- Do not turn the main switch to [Stop] position while driving.
- Always shift gears firmly. When the transmission is not firmly shifted into a gear, it may jump out of the gear, resulting in loss of control of the machine.

⚠ CAUTION!

- Pinch hazard. Make certain that hands or fingers are not in the way to be caught when operating the clutch lever.
- You can not shift gears during driving. Always stop the machine when you shift the gears.
- Avoid sharp turns except in emergency situation.

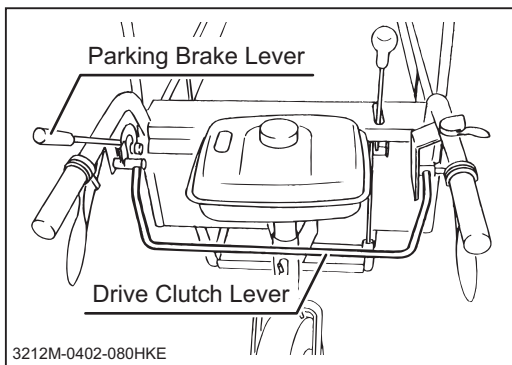

1. Make certain of the safety of your surroundings.
2. Make certain that the parking brake lever is in [ON] and the drive clutch lever is in [Stop] position.

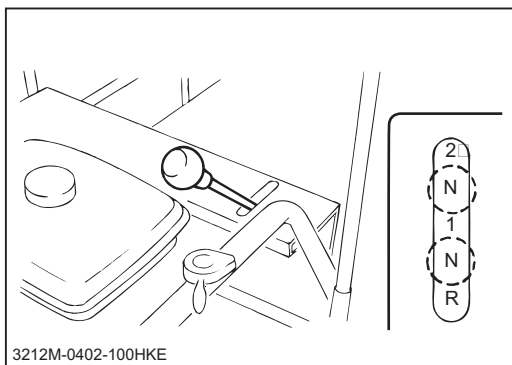

3. Move the shift lever into a desired position firmly.

NOTE

- Refer page 11 for the speed in each gear.
- When it is difficult to shift gear, move the clutch lever toward [Drive] position slightly and try again. It may help shifting smoothly.

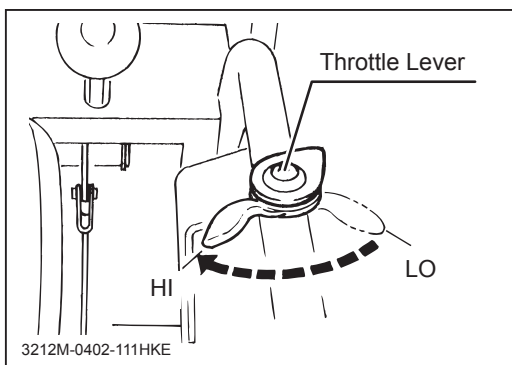

4. Move the throttle lever from [LO] to [HI] speed gently to increase engine speed.

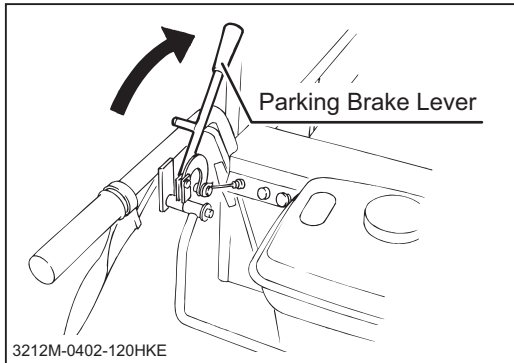

5. Move the parking brake lever forward to [OFF].

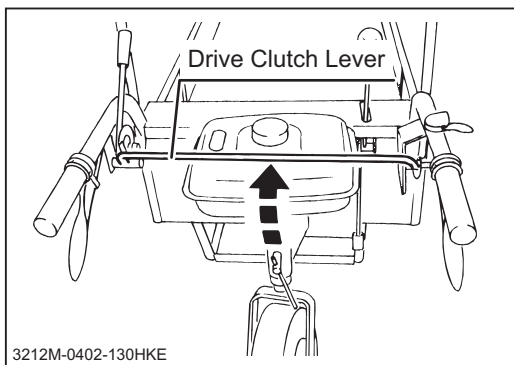

6. Pull up the drive clutch lever gently then move to [Drive] to start the machine.

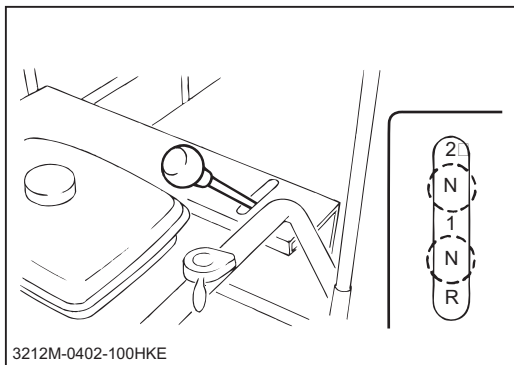

Shifting

7. After stopping the machine, do operation 1 to 3 when you shift gears.

NOTE

- For stopping the machine, refer to page 20, Parking.

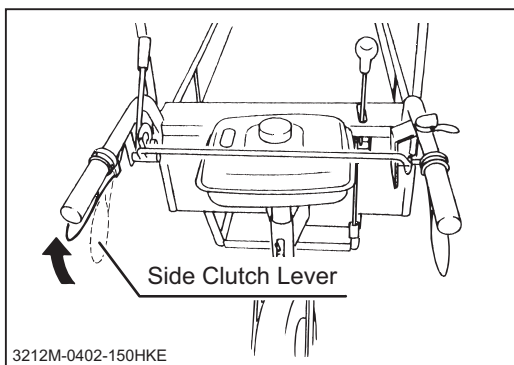

Turning - Left

8. Grasp the side clutch lever on the left hand side and steer the handle to the left a little.

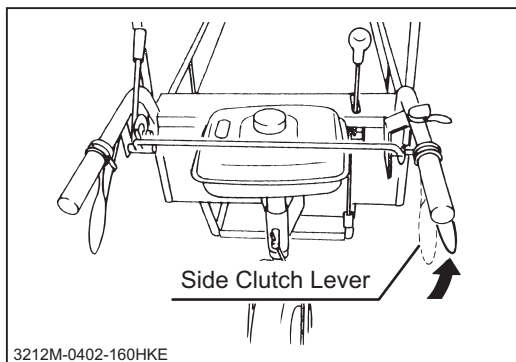

Turning - Right

8. Grasp the side clutch lever on the right hand side and steer the handle to the right a little.

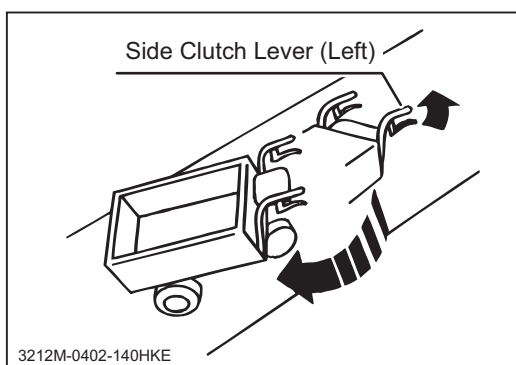

NOTE

- Be cautious when driving down a slope because the machine may move opposite to the intended operation.

Parking

⚠ WARNING!

- Do not make a sudden stop. The machine may skid or tip over.
- Always park on a firm, level place. Never park on a potentially dangerous place.

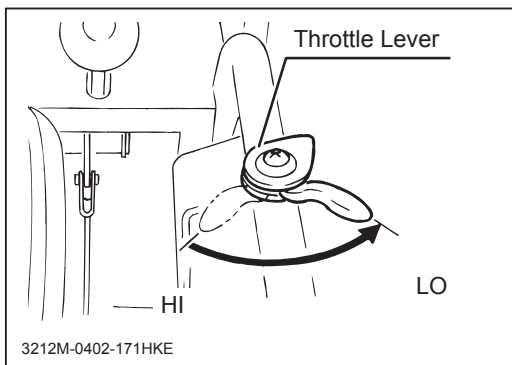

1. Move the throttle lever toward [LO] position to slow down.

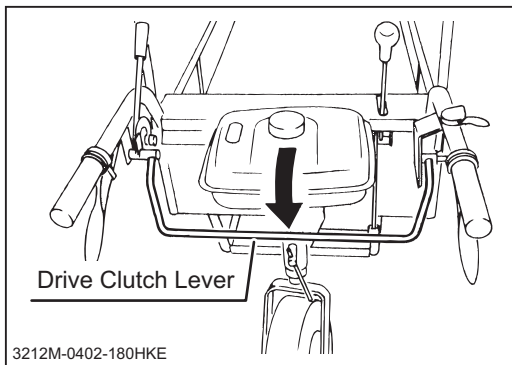

2. Move the drive clutch lever to [Stop] position to stop.

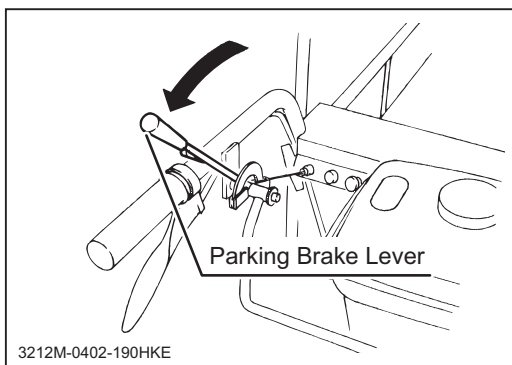

3. Pull the parking brake lever and move to [ON] position to stop the machine firmly.
4. Move the shift lever to [Neutral] position.

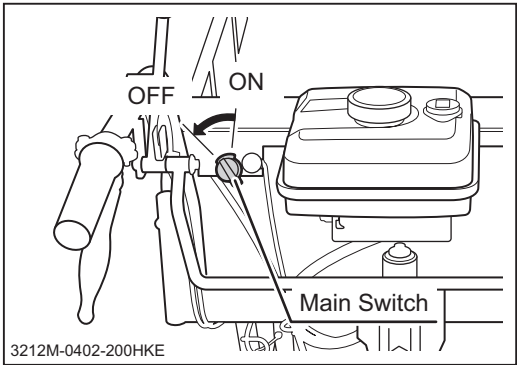

5. Turn the main switch [OFF] to stop the engine.

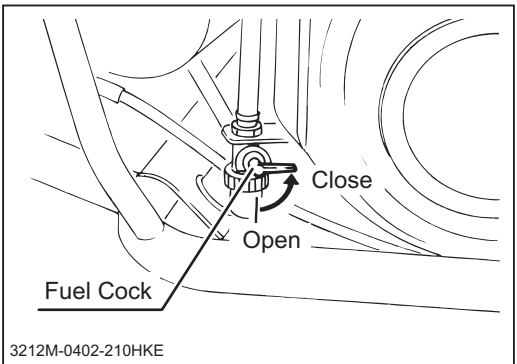

6. Close the fuel cock.

Maintenance Schedule

⚠ WARNING!

- Follow the scheduled maintenance as described below. Failure to do so may result in mechanical or property damage, injury or death.

Engine

Daily Inspection

- Fuel - not to be empty or dirty. no sediment or water in it.
- Air Cleaner Element - to be clean and free of damage.
- Engine Oil - to be clean and at the correct level.
- Bolts, Nuts, Fasteners - not to be loose or missing.
- Leaks - no fuel or oil leaks to be found.
- Sound, Vibration - no abnormal noise or excessive vibration.
- Overall - to be clean, without missing pieces.

Scheduled Maintenance

Hours used	Before use (daily)	25 hours	50-100 hours	100-300 hours
Check and tighten fasteners	○			
Check and fill oil	○			
Change oil		● (1st time only)	○	
Check fuel or oil leaks	○			
Check and clean air cleaner element	○			
Clean recoil starter	○			
Clean muffler and muffler cover	○			
Check and clean spark plug			○	
Check and clean fuel filter			○	
Remove carbon deposit from cylinder head				◎
Check and adjust valve clearance				◎
Replace fuel hose	Every three years (or as needed)			

◎: for the items made with this symbol, please consult with your CANYCOM representative.

Chassis

- Perform a pre-startup inspection (PSI) before each use, a monthly inspection once a month, and a yearly inspection once a year.
- Some maintenance procedures described below may require special knowledge or tools and instruments. Contact your CANYCOM representative to perform such procedures.

Item	Description	Schedule			Note		
		PSI	Mon	Year			
Drive Train	Drive Clutch	- Clutch shall not make any abnormal noise and shall disengage completely when operated at idle.	Clutch shall disengage completely without any abnormal noise.	√	√	√	Page 32
		- Engage clutch gradually and check for slippage.	Clutch shall engage smoothly without slipping.	√	√	√	Page 32
	V - Belt	- Belt shall be free of crack or damage.	There shall be no crack or damage. No oil shall be on found the belt.		√	√	Page 32
		- Belt tension shall be properly adjusted.	Tension shall be appropriate.		√	√	Page 32
	Transmission	- Transmission shall not jump out of the gear. Irregular noise or overheating shall not be observed.	Transmission shall not jump out of gear, and no irregular noise or overheating to be found.	√	√	√	
		- Check oil level inside the transmission.	Oil must be at the correct level.		√	√	Page 31
		- Check for the condition of oil.	Oil must be clean.		√	√	
		- Check for oil leakage from transmission.	There shall be no oil leak.		√	√	
	Side Clutch	- Side clutch levers shall work normally without abnormal noise.	Side clutch works properly without abnormal noise.	√	√	√	
		- Check for play and stroke of the levers.	Appropriate play and stroke for the levers.	√	√	√	Page 34
		- Check for excessive play and rust on the pins, rods, links, bearings and connectins.	There shall be no excessive play or rust found in these parts.		√	√	

Item	Description	Schedule			Note		
		PSI	Mon	Year			
Tyres and Wheels	- Check for air pressure and tread depth.	Air pressure and tread depth shall be within the wear limit.	√	√	√		
	- Check for crack, damage or wear of tire and wheel.	There shall not be any crack or damage, and not worn beyond wear limit.	√	√	√		
	- See if metal pieces, stones, or other foreign objects are not jammed in the tread.	No foreign object shall be found in the tread.	√	√	√		
	- See if wheel bolts or hub are not loose or missing.	No bolts, nuts, or hubs shall be loose or missing.	√	√	√		
	- Check the play on the wheel bearing. See if there is abnormal noise or overheating.	Wheel bearing shall not have excessive play, and no abnormal noise or overheating to be observed.		√	√		
Brake System	- Drive the machine and see if the brake works properly	Brake must work properly.		√	√	Page 33	
	- Park the machine on a 20 degree slope unloaded and see if the machine stays.	The machine shall stay stationary on such a slope.	√	√	√	Page 33	
	- Check the pulling force and see if the brake lever returns normally.	The brake lever shall have correct pulling force and shall return normally.	√	√	√		
	Rods, Links, and Wires	- Check the rods, links, and wires for damage and tightness.	Rods, links, and wires shall not be damaged or loose.	√	√	√	
- Apply brake on and off to see if there is an excessive play. See if pins are not loose or missing.		There shall not be an excessive amount of play. No pins shall be loose or missing.	√	√	√		
Body, Chassis	Bed	- Check for crack, deformation or wear.	There shall not be any crack, deformation or wear.	√	√	√	
		- See if all the bolts and nuts are tightly fastened.	No bolt and nut shall be loose or missing.	√	√	√	
	Body	- See if covers are not cracked, deformed, loose or with missing fasteners.	No covers shall be cracked, deformed, loose, or with missing fasteners.		√	√	

List of Fluids and Lubricants

Item	Schedule	Grade	Capacity
Fuel	As needed.	Automotive unleaded gasoline.	2.5L
Engine Oil	Fill Inspect daily. Fill as needed. Change Initially - After 25 hours of use. Every 50 hours afterwards.	Automotive gasoline engine oil API rating: SE or better. SAE rating: 10W-30 or 10W-40	0.5L
Transmission Oil	Change Initially - After 50 hours of use. Every 500 hours afterwards.	Gear Oil API rating: GL-4 or 5 SAE rating: #80	1.0L
Lubrication Points (Drive clutch lever and tension arm pivots)	Every 6 months No need to lubricate for 6months after purchase.	Gear Oil API rating: GL-4 or 5 SAE rating: #80	—

Lubrication

⚠ CAUTION!

- Follow the maintenance schedule to lubricate the machine. Lack of lubrication may result in rust, excessive wear or seizure.

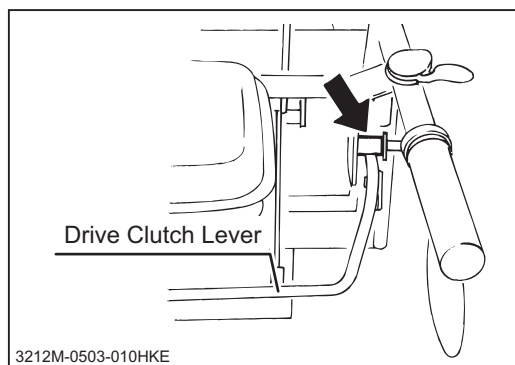

Lubricate the following points

- Drive clutch lever pivot (Right)

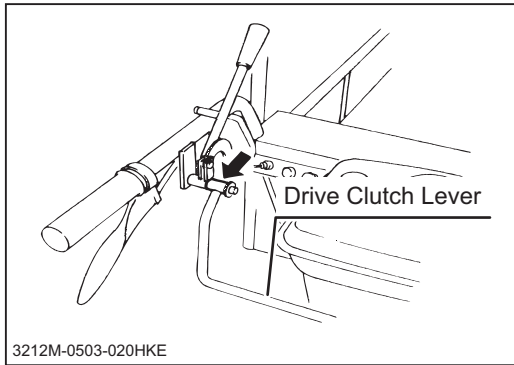

b. Drive clutch lever pivot (Left)

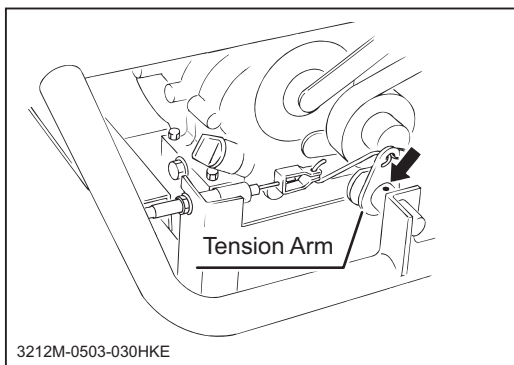

c. Drive clutch tension arm pivot

List of Consumables and Spares

⚠ CAUTION!

- When replacing a consumable or spare, always use the CANYCOM genuine part.

Item		Part Number	Schedule	Quantity
Air Cleaner Element		KA01049AA 003	Check every 50 hours (every week). Replace as needed	1
Fuel Filter		KF31035AA003	Check every 200 hours (every month). Replace as needed	1
V- Belt		08521300049	Replace if defective.	1
Brake Lining		79539901000	Replace if defective.	1 set (replace as a set)
Tire	Front	53042301000	Replace if defective.	2
	Rear	32052205000	Replace if defective.	1
Others			Please contact your CANYCOM representative	

Engine

⚠ WARNING!

- Always stop the engine before servicing.
- Allow the engine to cool off before servicing. The engine is very hot after operation and may pose a burn hazard.
- Keep fire and spark away when handling fuel.

Engine Oil

⚠ CAUTION!

- Dispose of drained oil properly.
- Make certain to fill the engine with correct grade of oil to the specified level. Insufficient amount or wrong grade of oil reduces performance and may cause permanent damage to the engine.

NOTE

- To obtain correct reading, check oil level before starting, or wait about 10 minutes after stopping the engine to allow oil to drain back to oil pan. Circulating oil stays in various parts of the engine right after stopping.
- Always check oil level on a level ground.
- Recommended Oil and Quantity: see "List of Fluids and Lubricants" (page 25)

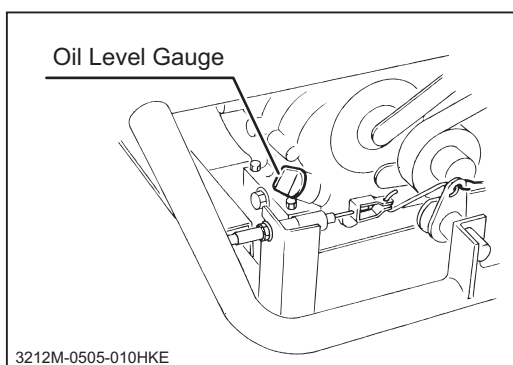

Inspection / Filling

1. Remove the oil gauge



2. Visually check oil level and condition of oil. Fill oil if level is low. Change, if dirty.
3. Install the oil level gauge.

NOTE

- Oil to use : see page 25
- Oil Level : between "F" and "L" of oil gauge

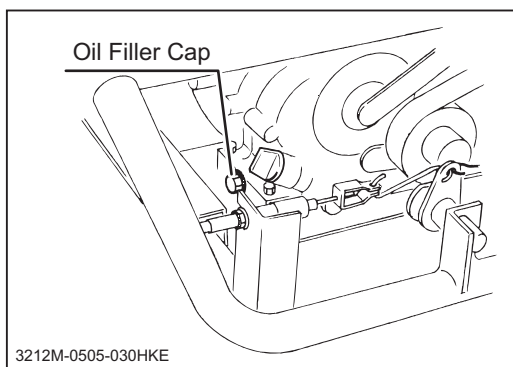
**Changing**

1. Prepare a suitable container to drain oil
2. Remove the oil drain plug and drain oil inside of the crank case.
3. Install the oil drain plug.
4. Remove the oil drain plug and refill specified oil. (Refer to "Inspection/ Refilling" above.)

Air Cleaner Element**⚠ CAUTION!**

- Clean the air cleaner element regularly. Dirty cleaner element reduces engine performance and life.
- Type of air cleaner element and cleaning method vary depending on the engine type. Refer to the attached manual for the engine and clean the element accordingly.

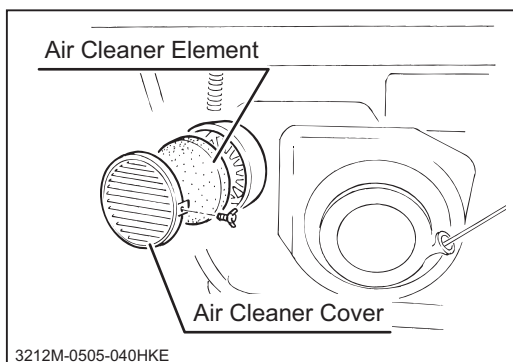
**Cleaning / Replacing**

1. Follow the instructions in "**Operator's Manual for the Engine**" to clean or replace the air cleaner element.

Spark Plug

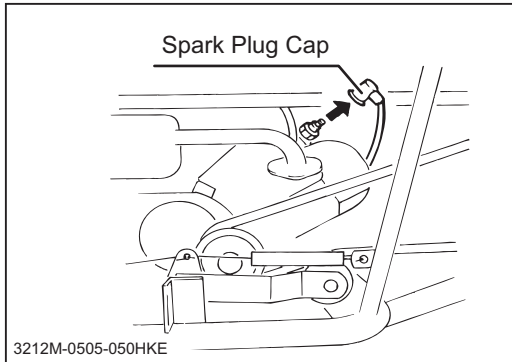

Inspecting

1. Remove the spark plug cap and spark plug.
2. Follow the instructions in "**Operator's Manual for the Engine**" to inspect, clean, or replace the spark plug.
3. Put the spark plug and spark plug cap back in place.

Fuel Filter

⚠ WARNING!

- Fuel is highly flammable. Keep fire and spark away when servicing the fuel filter.
- If fuel is spilt, wipe it off immediately.
- Dispose of waste fuel properly.

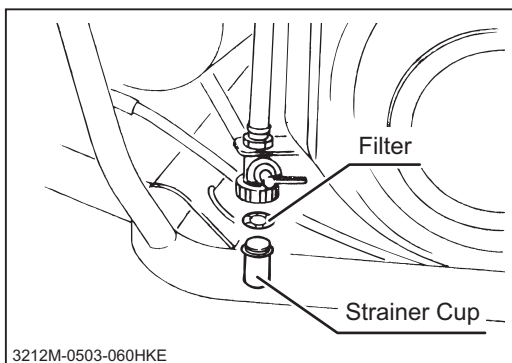

1. Follow the instructions in "**Operator's Manual for the Engine**" to clean the fuel filter.
2. Start the engine and visually inspect the fuel filter cup so that there is no leak.

Drive Train

⚠ WARNING!

- Stop the engine when servicing the drive train.
- Allow the machine to cool off before servicing. The engine is very hot after operation and may pose a burn hazard.

⚠ CAUTION!

- Dispose of drained oil and fluids properly.

Tires

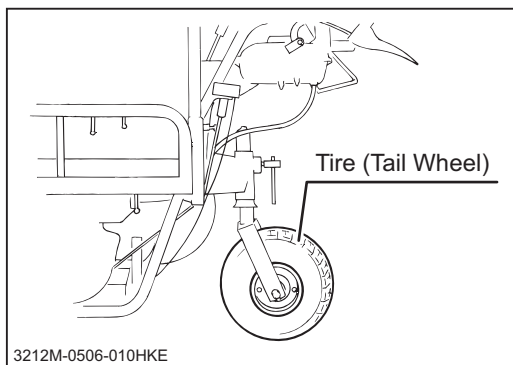

1. Check air pressure of the front and tail wheels and adjust if needed.

Tire		Air Pressure
		kPa(Kgf/cm ²)
Front	AGP 16x7.00-8 2PR	60 (0.6)
Tail	HC 3.50-5 2PR	180 (1.8)

Transmission Oil

⚠ CAUTION!

- Make certain to fill transmission with the correct grade of oil to the specified level. Insufficient amount or wrong grade of oil reduces performance and may cause permanent damage to the transmission.

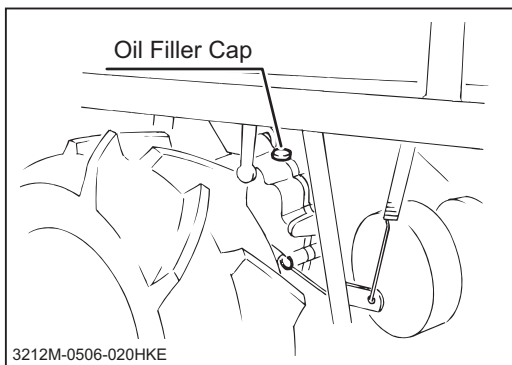

Inspection / Refilling

1. Park the machine on a level surface.
2. Remove the transmission oil filler cap.
3. Visually check the oil level and condition of oil. Fill oil if the level is low. Change, if dirty.

NOTE

- Oil Capacity : see page 25
- Oil to Use : see page 25

4. Install the oil filler cap.

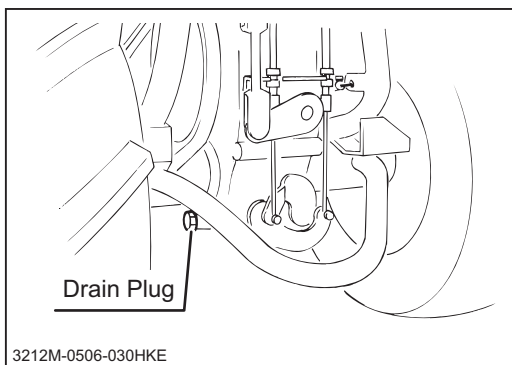

Replacing

1. Prepare a suitable container to drain oil
2. Remove the oil drain plug and drain oil.
3. Install the oil drain plug.
4. Remove the oil filler plug and refill specified oil. (Refer Inspection / Refilling)

NOTE

- Removing the oil filler cap will help drain oil faster.

Drive Belt

⚠ CAUTION!

- Adjust belt tension properly. An improperly tensioned belt may reduce performance and its service life.
- Dragging of clutch may be caused by the inappropriately adjusted belt stopper. Adjust the belt stopper after replacing the drive belt.

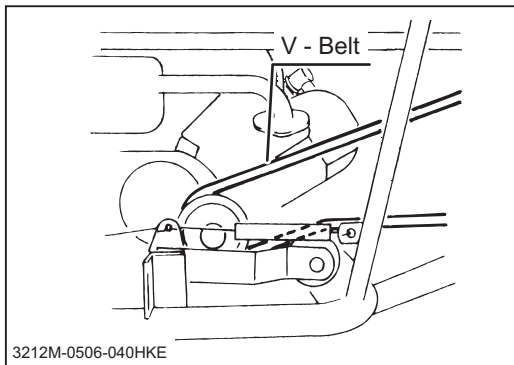

Inspecting

1. Visually check if the drive belt is damaged. Replace the belt if necessary. (Please contact your CANYCOM representative for replacing the belt.) Refer to "Drive Clutch" section.

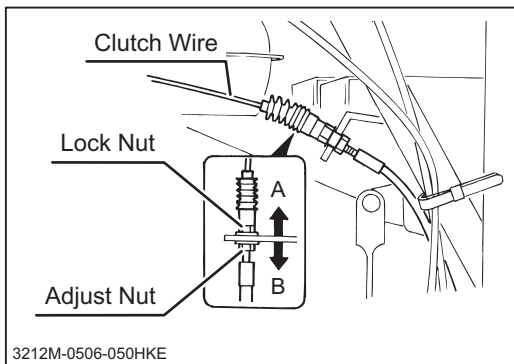

Adjusting - Drive Clutch

1. Move the drive clutch lever to [Stop] so that the clutch wire is not tensioned.
2. Loosen the lock nut on the clutch wire.
3. Rotate the adjust nut to adjust the clutch wire.
 - When the clutch does not disengage well, turn the adjust nut toward B
 - When the V-belt slips, turn the adjust nut toward A
4. Tighten the lock nut securely after adjusting.

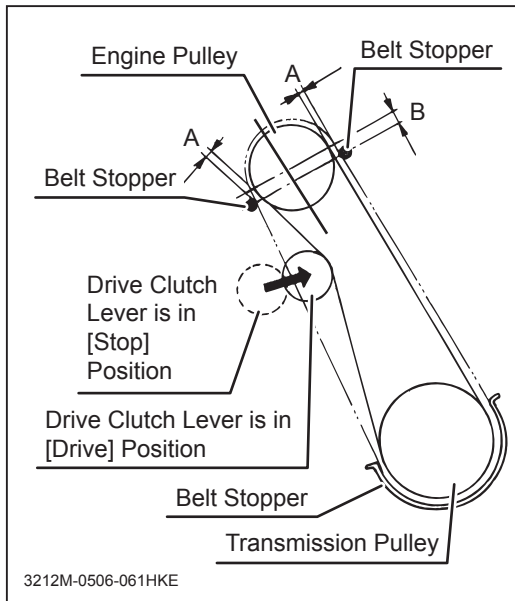

Adjusting - Belt Stopper

1. Remove the safety cover.
2. Shift the drive clutch lever to [Drive] then adjust the clearance A between the V- belt and the belt stopper to be about 5 mm and the clearance B to be between 10 and 20 mm.
3. Set the clearance around the transmission pulley between the belt and the belt stopper to be even for whole circumference.

Parking Brake

⚠ WARNING!

- Always keep the brake adjusted for maximum performance. Improperly adjusted brakes may result in property damage, serious injury, or death.

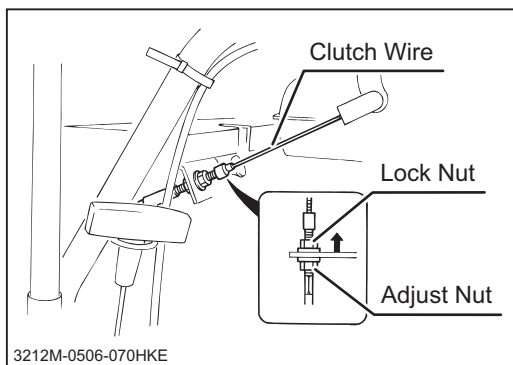

1. Move the parking brake lever to [OFF] to take tension off the brake wire.
2. Loosen the lock nut on the brake wire.
3. Rotate the adjust nut to adjust the brake wire.
 - When the brake does not work well, turn the adjust nut toward the direction of the arrow (see illustration).
4. Tighten the lock nut firmly after adjusting.

Side Clutch

⚠ CAUTION!

- In case there is too much play on the side clutch lever, adjust it with the adjust nut on the side clutch rod.
- If the play increases or the machine does not turn smoothly, adjust the side clutch with the adjust nut on the side clutch wire.

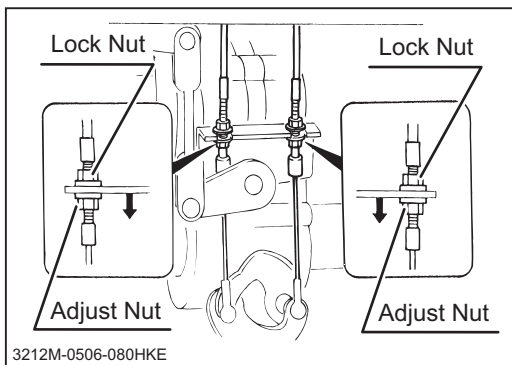
**When There is Too Much Play**

1. Loosen the lock nut on the side clutch wire.
2. Rotate the adjust nut toward the direction indicated with an arrow (see illustration) to adjust the play on the side clutch lever.

NOTE

- Play on the side clutch lever: 1 to 5 mm (at the lever end)

3. Tighten the lock nut firmly after adjusting.

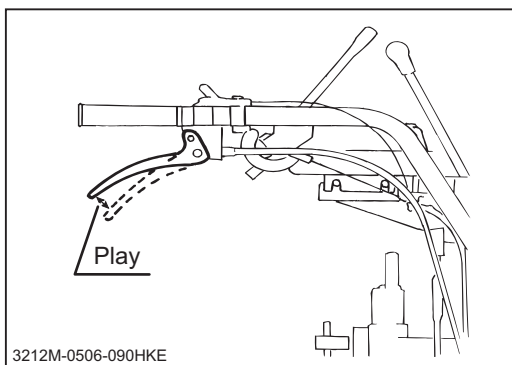

After Use Care

⚠ CAUTION!

- Do not wash the engine, control panel, electrical parts, or tank caps with air breather with running water; water may enter inside and cause rust or damage.
- Clean the machine after use; leaving dirt or foreign objects may cause damage.
- Do not attempt to move the machine when it becomes inoperable due to freezing.

After Normal Use

1. Clean the machine; wash off dirt, mud, and other foreign matter after use.
2. If the machine is to be parked outside, cover the machine with a protective, water-proof covering after the machine cools off.

After Cold Weather Use

1. Clean the machine; wash off dirt, mud, and other foreign matter after use.
2. Park the machine on a paved or firm, dry surface.
3. If the machine is to be parked outside, cover the machine with a protective, water-proof covering after it cools off.

Storage

⚠ WARNING!

- Fire hazard; do not store machine where there is a possibility of ignition.

⚠ CAUTION!

- Do not wash engine or control panel with running water; water may enter inside and cause rust or damage.
- Clean machine before storage; leaving dirt or foreign objects may cause rust or damage.
- Do not store machine in a humid, dusty, or hot place.
- Do not leave machine with petrol in the carburetor. It may cause difficulty with starting or irregular idling. Drain petrol in the carburetor when you store machine for long time period. Avoid use petrol left for long time.

1. Follow the instructions in "**Parking**" (page 22) to park machine.
2. Clean dirt off of machine.
3. Follow the instructions in "**Operator's Manual for the Engine**" to prepare engine for storage.
4. Remove battery from machine (electric start model).
5. Cover machine with a protective, water-proof covering after machine cools off.

NOTE

- Refer to "**Operator's Manual for the Engine**", for detailed instructions on preparing engine for storage.

Troubleshooting

- If any malfunction or abnormal condition is found, immediately stop using the machine and take an appropriate measure according to the Troubleshooting chart below. If the malfunction or abnormal condition is not listed in the chart, or the suggested measure does not solve the problem, consult with your CANYCOM representative.
- Some corrective measures listed below require special knowledge and/or equipment. Please contact your CANYCOM representative in such a case.

Area	Malfunction	Possible Cause	Corrective Measure	Ref.
Engine	Engine does not start, or is difficult to start.	Out of fuel.	→Fill fuel.	Page 12
		Engine is flooded (too much fuel fed into the engine).	→Wait and restart.	
		Fuel cock is closed	→Open fuel cock.	Page 14
		Poor ignition due to a problem with spark plug.	→Clean or replace spark plug.	Page 29
		Other (other than the above).	→Follow the instructions in " Starting " to restart. If problem persists, please contact your CANYCOM representative.	
	Engine stalls.	Engine is cold.	→Warm up engine.	
		Choke knob is in [Close] position.	→Move choke knob to [Open] position.	Page 15
		Other (other than the above).	→Please contact your CANYCOM representative.	
	Engine stops abruptly.	Out of fuel.	→Fill fuel.	Page 12
		Other (other than the above).	→Please contact your CANYCOM representative.	
	Irregular Idling	Air cleaner element is clogged	→Clean or replace air cleaner element.	Page 28
		Other (other than the above).	→Please contact your CANYCOM representative.	

Area	Malfunction	Possible Cause	Corrective Measure	Ref.
Engine	Poor power or acceleration	Bad fuel	→Change fuel.	
		Insufficient intake air (clogged air cleaner).	→Clean or replace air cleaner element.	Page 28
		Loose drive belt.	→Adjust drive belt.	Page 31
		Excessive load	→Reduce load.	
		Other (other than the above).	→Please contact your CANYCOM representative.	
	Irregular noise or vibration from or around the engine		→Please contact your CANYCOM representative.	
	Excessive oil consumption		→Please contact your CANYCOM representative.	
	Engine overheats	Insufficient amount of engine oil.	→Fill oil.	Page 27
		Other (other than the above).	→Please contact your CANYCOM representative.	
	Excessive Fuel consumption	Insufficient intake air (clogged air cleaner).	→Clean or replace air cleaner element.	Page 28
		Other (other than the above).	→Please contact your CANYCOM representative.	
	Black smoke comes out of exhaust	Choke knob is in [Close] position.	→Move choke knob to [Open] position.	Page 15
		Air cleaner is clogged.	→Clean or replace air cleaner element.	Page 28
		Other (other than the above).	→Please contact your CANYCOM representative.	
	White or blue smoke comes out of exhaust	Bad fuel.	→Change fuel.	
		Wrong engine oil.	→Change oil.	Page 27
		Other (other than the above).	→Please contact your CANYCOM representative.	
	Accelerator lever is catching		→Please contact your CANYCOM representative.	

Area	Malfunction	Possible Cause	Corrective Measure	Ref.
Drive Train	Machine does not move when clutch lever is in the [Run] position.	Transmission is not positively in the gear.	→Shift firmly.	
		Loose drive belt.	→Adjust drive belt	Page 31
		Other (other than the above).	→Follow instructions in "Driving" to drive. If problem persists, please contact your CANYCOM representative.	Page 16
	Clutch does not disengage positively.	Improperly adjusted drive belt.	→Adjust drive belt	Page 31
		Other (other than the above).	→Please contact your CANYCOM representative.	
	Drive belt slips.	Loose drive belt.	→Adjust drive belt	Page 31
		Other (other than the above).	→Please contact your CANYCOM representative.	
	Transmission jumps out of gear.	Transmission is not positively in the gear.	→Shift firmly.	
		Excessive load	→Reduce load.	
		Other (other than the above).	→Please contact your CANYCOM representative.	
	Machine does not turn smoothly.	Improperly adjusted side clutch.	→Adjust side clutch	Page 34
		Other (other than the above).	→Please contact your CANYCOM representative.	
	Irregular noise or abnormal heat from roller, sprocket, or idler.		→Please contact your CANYCOM representative.	
	Brake	Brake does not work well.	Improperly adjusted brake.	→Adjust brake.
Brake is wet with water.			→Apply brake a few times to dry.	
Excessive load			→Reduce load.	
Other (other than the above).			→Please contact your CANYCOM representative.	

Hauling

Loading and Unloading

⚠️ WARNING!

- Park the transporter (truck) on a level ground. Always use chocks to secure wheels.
- Do not allow bystandars to come close to the machine or transporter when loading or unloading the machine.
- Use only the loading ramps with sufficient strength (to withstand the combined weight of the machine and operator), width (more than 2 times the width of track), and length (more than 4 times the height of the bed of the transporter), and have anti-slip ramp surfaces.
- Secure hooks of the loading ramps firmly and flush with the bed of the transporter.
- Move slowly forward when loading onto, and move slowly backward when unloading off of the transporter. Pay special care when going over the joint between the bed and ramps; the machine may tip.
- Do not turn on the loading ramps. The machine may fall.
- Tie down the machine securely. Make sure the machine does not move around on the bed.

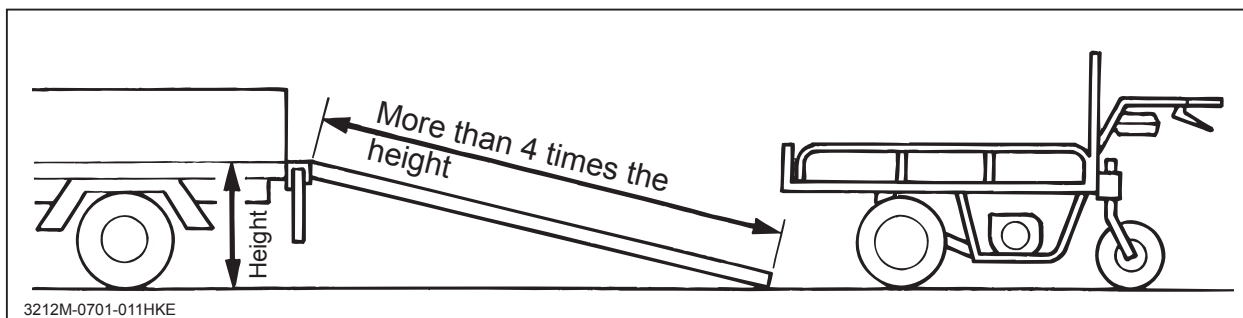

1. Park the transporter on a level ground. Secure the wheels with chocks.
2. Place the loading ramps. Secure the hooks of the ramps firmly and flush with the bed of the transporter.

3. Drive the machine slowly forward onto the bed.
4. Park the machine according to the instructions in "**Parking**" (page 20). Secure the machine firmly to the bed of the transporter with tie-down belts, rope, or wire.