

Front Flail Brushcutter

# CG431 Tractor

---

## Operator's Manual

---

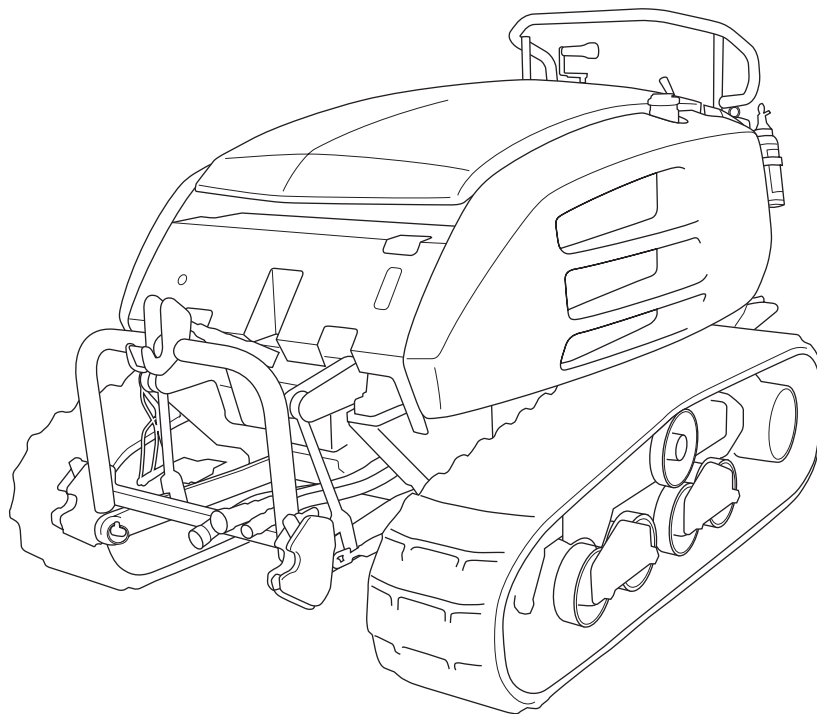

### **⚠ WARNING!**

Read this manual completely before operating or maintaining this machine. Failure to follow safety precautions could result in serious injury or death. Keep this manual for future reference by you and by all those who operate and maintain this machine.

5116 5103 000

---

**Original Instructions**  
(in English)

**CHIKUSUI CANYCOM, INC.**  
90-1 Fukumasu, Yoshii-machi,  
Ukiha-shi, Fukuoka, Japan 839-1396  
Tel.+81-(0)943-75-2195 Fax.+81-(0)943-75-4396

---

# CHIKUSUI CANYCOM, INC.

<http://www.canycom.co.jp/>

---

- Sales Headquarters TEL +81-(0)943-75-2195 FAX +81-(0)943-75-4396
- Foreign Trade Center TEL +81-(0)3-3552-6277 FAX +81-(0)3-3552-6288

Authorized Dealer

---

## Notice to Users and Maintenance Personnel

Thank you for purchasing this machine.

This manual provides information needed for safe and effective use and maintenance of this machine to those who operate or maintain the machine. Make sure to read and understand the manual thoroughly before operating or servicing the machine. Also make sure to read the separate operator's manual for engine.

### **⚠ WARNING!**

- **This machine can be very dangerous if the safety precautions in this manual and on the labels attached to this machine are not followed. Read and understand this manual and the safety labels on the machine thoroughly before using or servicing the machine. Always follow the instructions and safety precautions, or serious injury or death could result.**
- **This machine should only be used for its intended purpose: brushcutting. Any other use could be dangerous.**
- **This machine may not be operated on public road or what is considered to be public road. It is the sole responsibility of the operator to consult the local regulations.**
- **Do not modify this machine, or do not operate this machine with safety covers removed or open. A serious accident could result.**

### **⚠ CAUTION!**

- **Store this manual in a safe, accessible place for easy reference.**
-

---



## Notice to Owner

### CAUTION!

- Be sure that everyone who uses this machine, including those who rent or lease this machine, receives a copy of this Operator's Manual and understands the importance of reading and following the information in this manual.

## Warning Terms Used in this Manual

In this manual, the following four warning terms are used to signal the four levels of hazard (or seriousness of possible accidents). Read and understand what they mean and always follow the instructions in this manual.

Warning Term	Definition
 <b>DANGER!</b>	Indicates an imminently hazardous situation which will result in death or serious injury if the user does not follow the procedures or the instructions.
 <b>WARNING!</b>	Indicates a potentially hazardous situation which could result in death or serious injury if the user does not follow the procedures or the instructions.
 <b>CAUTION!</b>	Indicates a potentially hazardous situation which could result in minor to moderate injury or damage to the machine if the user does not follow the procedures or the instructions.
<u>NOTE</u>	Indicates important information which needs particular attention.

---

---

# Warranty and After-Sales Service

## Warranty

CHIKUSUI CANYCOM, INC. guarantees this product, based on the terms of warranty. A copy of this warranty is reproduced in the back of this manual.

## After-Sales Service

Consult your local CANYCOM dealer or our company's sales department regarding service orders or any questions or problems that may arise when using this machine. Please make sure to have the product name, serial number, and the make and type of engine handy at the time of contact. The model and serial numbers can be found on the model label as shown below, and the make and type of the engine can be found in Chapter 3 "Specifications" of this manual (Page14).

### Location of Model Label

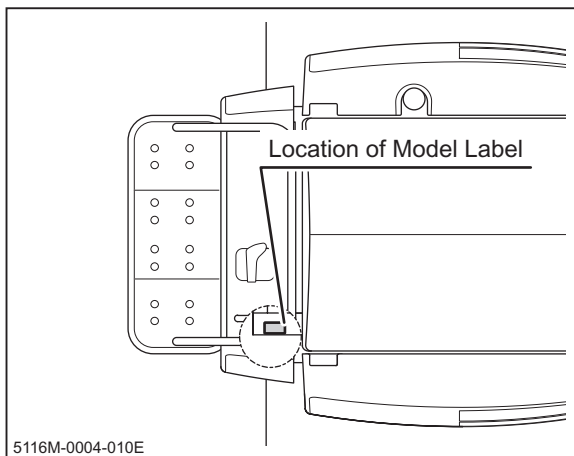

### Model Label



## Availability of Spare Parts

The replacement or repair parts for this product shall remain available for seven years after the production of this type of machine is discontinued.

---

---

# Contents

## **1. Safety 1**

Safety Labels ..... 1

Safety Precautions ..... 3

    Training ..... 3

    Preparation ..... 4

    Operation ..... 4

    Servicing ..... 8

## **2. Controls and Components 10**

Name and Function of Controls ..... 10

## **3. Specifications 14**

Product Specifications ..... 14

Contents of Tool Bag ..... 15

## **4. Operation 16**

Preparation ..... 16

    Pre-start up Inspection ..... 16

    Checking and Filling Fuel ..... 16

    Unfolding/Folding Step ..... 17

---

---

<b>Driving</b> .....	<b>18</b>
Starting .....	18
Driving .....	22
Stopping .....	24
<b>Working</b> .....	<b>26</b>
Operating Cutting Rotor .....	27
Changing PTO Speed (Variable PTO Speed Model Only) .....	29
Translating Cuttong Rotor .....	30
Levelling Step .....	31
Hydraulic Cooling Fan .....	32
<b>Fire Extinguisher</b> .....	<b>33</b>
Fire Extinguisher Location .....	33
Using Fire Extinguisher .....	33

## **5. Maintenance** **34**

<b>Maintenance Schedule</b> .....	<b>34</b>
<b>List of Fluids and Lubricants</b> .....	<b>39</b>
<b>Grease Points</b> .....	<b>40</b>
<b>List of Consumables and Spares</b> .....	<b>40</b>
<b>Body Panels</b> .....	<b>43</b>
Opening Top Cover .....	43
Removing Side Covers .....	44
Removing Front Cover .....	44
Removing Controls Cover .....	44

---

---

<b>Engine</b> .....	<b>45</b>
Engine Oil .....	45
Oil Filter .....	47
Coolant .....	47
Air Cleaner .....	50
Fan Belt .....	51
<b>Fuel System</b> .....	<b>52</b>
Bleeding .....	52
Draining Water .....	52
Fuel Filter Cartridge .....	53
<b>Hydraulic System</b> .....	<b>54</b>
Hydraulic Fluid .....	54
Suction Filter .....	56
Return Filter Element .....	57
<b>Drive Train</b> .....	<b>58</b>
Track .....	58
Drive Motor Lubricant .....	59
Greasing .....	60
Control Stick .....	61
<b>Electrical System</b> .....	<b>62</b>
Battery Fluid .....	62
Charging Battery .....	64
Fuses .....	65
Slow-Blow Fuses .....	66
<b>Implement</b> .....	<b>68</b>
Attaching/Detaching Implement .....	68

---



---

<b>After Use Care</b> .....	<b>69</b>
After Normal Use .....	69
After Cold Weather Use .....	69
<b>Storage</b> .....	<b>70</b>

## **6. Troubleshooting 71**

Troubleshooting .....	71
-----------------------	----

## **7. Transporting 76**

<b>Hauling</b> .....	<b>76</b>
Loading and Unloading .....	76
<b>Hoisting and Towing</b> .....	<b>78</b>

## **Warranty**

Warranty Certificate is attached at the end of this manual.

\* Have the warranty certificate signed and sealed after you have received and fully understood the instructions for handling this machine and received the receipt.

## **Appendix**

- Operator's Manual for Engine
  - \* Be sure to read and understand it together with this manual .
-

## Safety Labels

Safety labels shown on the next page are attached to the machine. See the illustration below for the location and the illustration on the next page for the content of each label on the machine.

- **Locate all warning labels attached to this machine. Read and follow the instructions and precautions in them. Failure to do so could result in serious injury or death to the operator or bystanders.**
- **Keep labels clean and legible. Do not use solvents or gasoline to clean labels.**
- **Replace these labels immediately if they have been removed, have fallen off or become illegible. Use part number written on the label or shown in this manual to order a replacement label from your CANYCOM representative.**

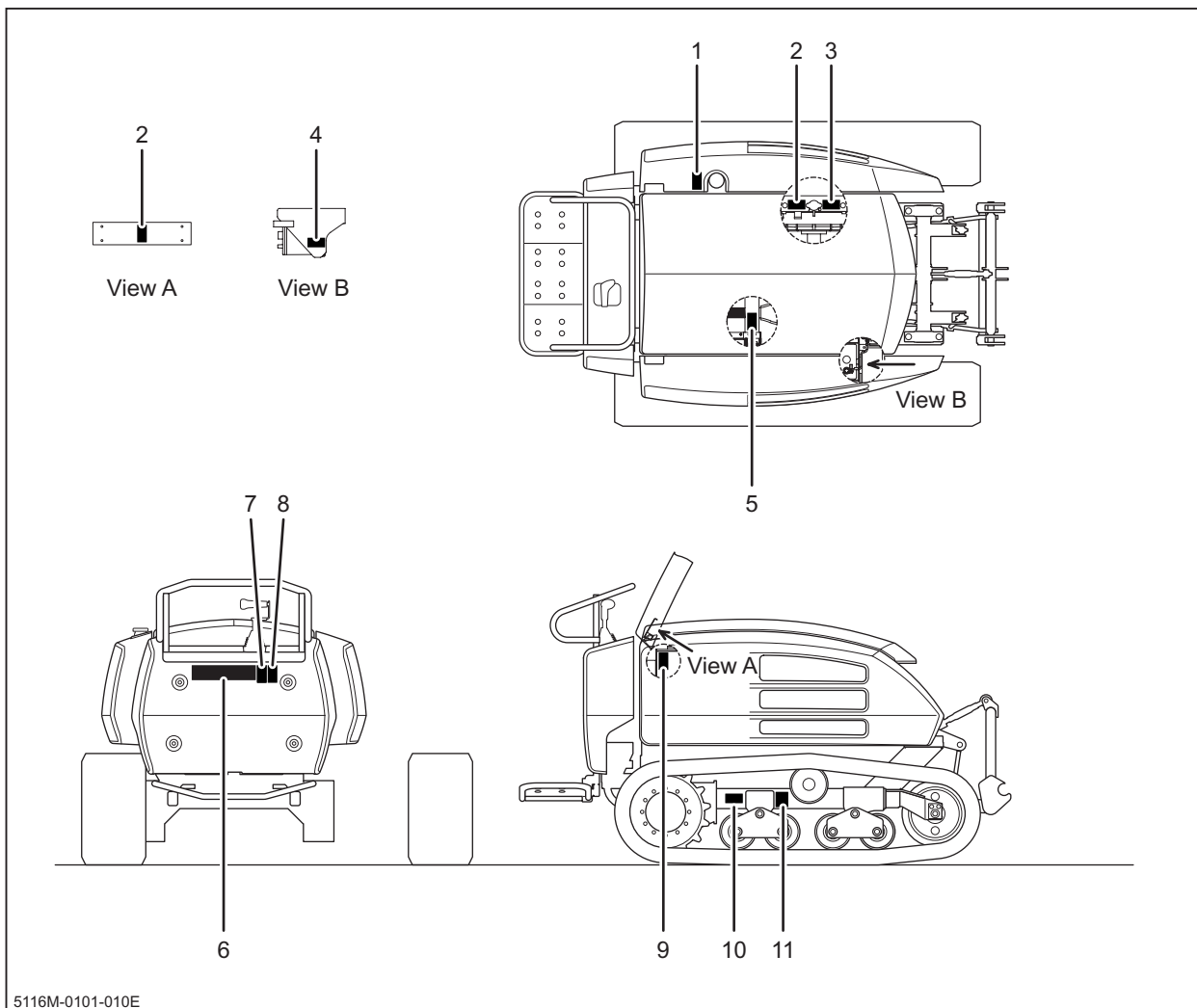

1. 5116 5224 000



2. 5116 5225 000



3. 5229 5221 000



4. 5229 5222 000



5. 5229 5225 000



6. 5116 5218 000

<p><b>CAUTION!</b></p> <p>Do not work on slope more than 30 degrees. Do not turn on a slope. Do not work on a slippery surface. Always check for holes and obstacles before working. Use extra care when operating machine.</p>	<p><b>CAUTION!</b></p> <p>This machine is equipped with a security system that shut off engine before it gets overheating. Refer operator's manual to cope with problem.</p>	<p><b>CAUTION!</b></p> <p>Stop engine immediately and remove foreign object when foreign object coil around cutting rotor. Otherwise it may cause abnormal vibration by unbalanced cutting rotor and may cause malfunction.</p>	<p><b>WARNING!</b></p> <p>Never work with reverse cutting rotor direction when using implement translation function. It may cause serious injury by thrown object such as gravel stone.</p>
---	--	---	---

7. 5116 5223 000

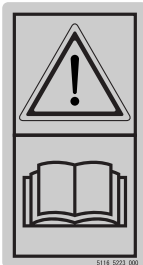

8. 5116 5227 000



9. 5116 5225 000



10. 5116 5241 000



11. 5116 5258 000

<p><b>CAUTION!</b></p> <p>Always remove the valve when loosening the crawler. When installing the valve, make sure the O-ring is free of damages. Install carefully not to jam the O-ring.</p>
--

---

## Safety Precautions

This section contains safety precautions to follow when operating and maintaining the machine. Read and understand the precautions in this section as well as throughout this manual and follow them when operating or maintaining machine. Failure to follow safety precautions could result in property damage, serious injury or death to the operator or bystanders.

## Training

All operators and mechanics should receive practical instructions from their employer or renter. Such instructions should cover the following issues:

- **It is essential to familiarize yourself with the controls, safety labels and proper use of the machine.**
- **Never allow people unfamiliar with these instructions to operate or service the machine. Do not let anyone under 18 years of age to operate this machine. Local regulations may restrict the minimum age for operating this type of machine. Consult your local authority.**
- **Operator is responsible for the accidents or hazards caused to other people or to their property.**
- **This machine has a riding capacity for one person only. Do not carry any passenger other than the operator.**
- **Always keep in mind that attention and concentration is required when working with ride-on machines.**
- **Loss of control on a slope cannot be regained by the application of the brake. Main reasons for the loss of control are:**
  - **insufficient grip of tracks.**
  - **excessive speed.**
  - **misjudging of ground conditions, especially slopes.**
  - **excessive load.**
  - **incorrect distribution of load.**

## Preparation

### **⚠ WARNING!**

- Fuel is highly flammable. See Checking and Filling Fuel, page 16, for important safety information on handling fuel.
- Always wear protective footwear, long trousers, hardhat, safety glasses and ear protection when operating or servicing the machine. Proper clothing will minimize the chance of injury. Do not operate the machine if you have long hair, loose clothing, or jewelry; all of which may get tangled in the moving parts. Do not operate the machine barefoot or with open sandals.
- Prepare beforehand the working rules and procedures such as signaling and traffic control for the work place. Following such rules will reduce the risk of accidents.
- Never handle fuel, lubricants or other flammable materials, service engine, or recharge battery in the presence of fire or spark.
- Perform daily pre-startup inspection (see Preparation, page 16) before starting the machine. Repair or replace damaged parts before starting the machine. Clean the machine of cut grass or such refuse to avoid fire.

## Operation

This machine is intended for brushcutting. By using other implements made or certified for this machine, it can perform other tasks. Use only the implements designed or certified specifically for this machine. Use of other implements may adversely affect the performance or stability of the machine and can cause damage or accident.

The stability of the machine is affected by the speed, rate of steering, terrain and load. Always pay close attention to these factors or a loss of control or overturn could occur, resulting in property damage, serious injury or death.

### General Driving

- Do not operate the engine in a confined space where dangerous carbon monoxide fumes can accumulate.

- Do not touch the engine, muffler or exhaust pipe while the engine is running or soon after it has stopped. These areas will be very hot and can cause burns.
- Do not operate the machine under the influence of alcohol or drugs. Do not operate the machine when you are tired, ill, or not feeling well.
- Always check for obstacles before operating on new terrain.
- Before starting the engine and the moving machine, scan around your surroundings and make sure all persons and other vehicles are a safe distance away from the machine. Sound the horn to warn bystanders.
- Stand firmly on the step. Always hold the guide rail with one hand to keep your posture when the machine is moving.
- On a slippery surface, travel slowly and exercise caution to reduce the chance of skidding or sliding out of control. Never operate on the ice.
- Always make certain that there is no obstacle or a person behind machine when backing up. After confirming that it is safe to back up, move slowly and avoid sharp turns.
- To reduce the risk of overturning, pay special attention when encountering an obstacle or a slope, or when braking on a slope or during a turn. See *Driving on a Slope* on the next page.
- Never attempt to drive over large obstacles such as rocks or fallen trees.
- Always travel slowly and use extra caution when operating on unfamiliar terrain. Be alert when traveling on changing terrain.
- Never operate on terrain that you are not comfortable with. Avoid terrain that is so rough, slippery or loose that you feel like you could overturn.
- Do not operate the machine near the edge of a cliff or a ditch, an overhang or a slide area. Pay special caution after rain or earthquake.

- Do not make sudden maneuvers. A sudden start, stop, or turn can make the machine lose control and could cause an overturn. Be especially cautious when traveling on soft or wet ground.
- Drive at a safe speed, taking into account the surface gradient, surface conditions and load.
- Use an observer to help direct the machine when the visibility is poor, terrain is rugged or hilly, or maneuvering room is limited. The observer should be able to see the machine and its immediate surroundings, and should give pre-arranged signals to direct the operator.

## Driving on a Slope

### **⚠ WARNING!**

- Never use on a slope steeper than 20 degrees.
  - Driving on a slope can be dangerous. It can cause an overturn, resulting in serious injury or death. Take the following precautions.
- Always follow the proper procedures for driving on a slope as described in this manual.
  - Driving on a slope in a wrong manner can cause a loss of control or a vehicle overturn. Check terrain carefully before attempting to drive on a slope.
  - Never drive on a slope that you are not comfortable with. Avoid a slope that is so rough, slippery, or loose that you feel like you could overturn.
  - When driving up a slope, proceed at a steady rate of speed and throttle position.
  - Never move the throttle lever or control stick suddenly.
  - If the engine stalls or loses traction during a climb and cannot make it to the top of a slope, do not try to turn the machine around. Carefully back down slowly, straight down the slope.

- Drive straight up or down a slope. Avoid turning on a slope.
- Avoid driving machine across a slope.
- When going over the top of a slope, go slow; an obstacle, a sharp drop, or another vehicle or person could be on the other side of the crest.
- Before driving down a slope, stop and turn auxiliary transmission switch to [LOW] position. Drive slowly. Use engine speed to help keep machine speed low.
- When driving down a slope, use the control stick so that the machine travels down at the minimum speed. Use engine speed to help keep machine speed low.

## Cutting

When conducting cutting operation, take the following precautions.

- Always follow the proper procedures for cutting as described in this manual.
- Shut off the work site. Post signs to inform that cutting operation is underway. Close off the site with rope if necessary to keep people, especially children, off the work site.
- Pay attention to the surrounding area. Running cutting rotor or implement throws stones, rocks and debris. This can cause property damage, injury, or death.
- Drive forward when cutting. This best prevents the cutting rotor or implement from throwing stones, rocks, or debris.
- Pay attention to obstacles. This includes overhead obstacles such as branches of a tree.



## Parking

- Park the machine on a flat, level and stable surface. Never park on a slope steeper than 15 degrees. Avoid parking on a slope less than 15 degrees. If parking on a slope less than 15 degrees is unavoidable, apply parking brake and block the tracks at the lower end of the machine.
  - Park the machine with operator's step uphill
  - Do not park sideways on a slope.
- Observe all the previous precautions for driving, driving on a slope and cutting.
- Whenever you park the machine, apply parking brake and stop the engine. Remove the key whenever you leave the machine unattended to prevent unauthorized use or accidental starting.
- Clean the machine of cut grass or such refuse after each use to avoid fire.
- Diesel fuel is flammable and can be explosive. When parking the machine indoors, make certain that building is well ventilated and that the machine is not close to any source of flame or spark, including appliances with pilot lights.

## Servicing

- Do not service the machine when the engine is running. If it is absolutely necessary to run the engine while servicing, pay attention to the moving parts; keep hands, feet, clothing and any part of your body away from any moving part, especially cooling fan and belts at the side of the engine.
- Do not operate the engine in a confined space where dangerous carbon monoxide fumes can accumulate.
- Make sure all hydraulic line connectors are tight and all hydraulic hoses and lines are in good condition and leak-free before applying hydraulic pressure to the system.
- Keep your body and hands away from pinhole leaks or nozzles that eject hydraulic fluid under high pressure. Use paper or cardboard, not your hands, to search for leaks. Hydraulic fluid escaping under pressure can have sufficient force to penetrate the skin and cause serious injury.

- Check all fuel lines on a regular basis for tightness and wear. Tighten or repair them as needed.
- Do not touch the engine, muffler, or exhaust pipe while the engine is running or soon after it has stopped. These areas will be very hot and can cause burns.
- Engine must be shut off before checking or adding oil.

# 2

# Controls and Components

## Name and Function of Controls

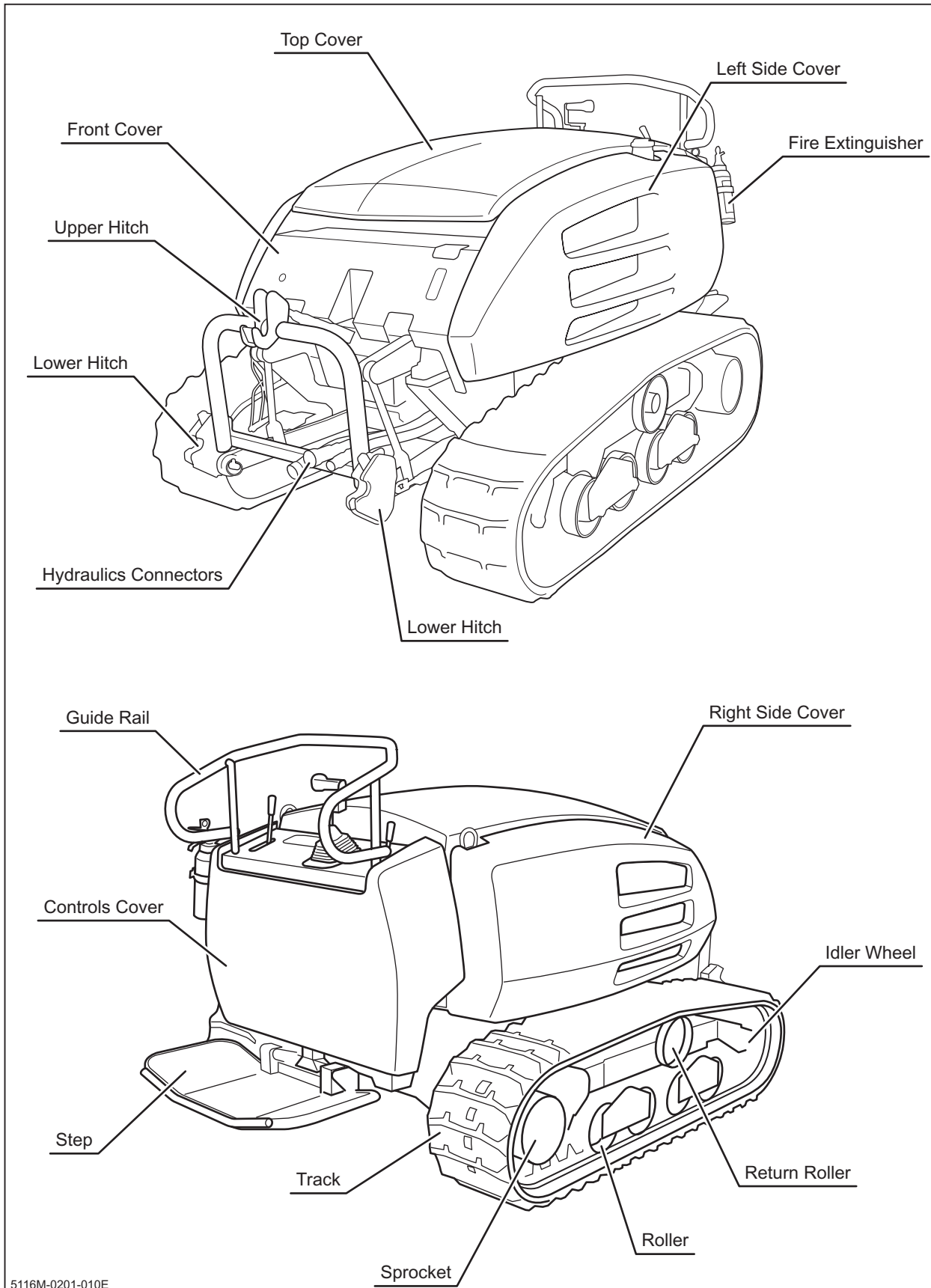

Normal Model

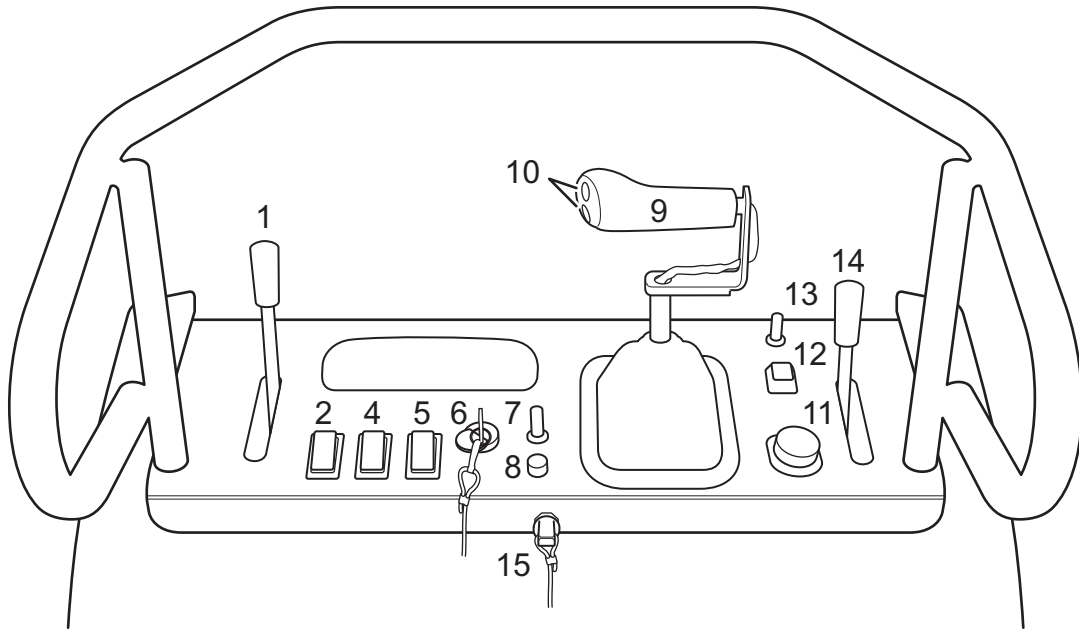

Variable Speed PTO Model

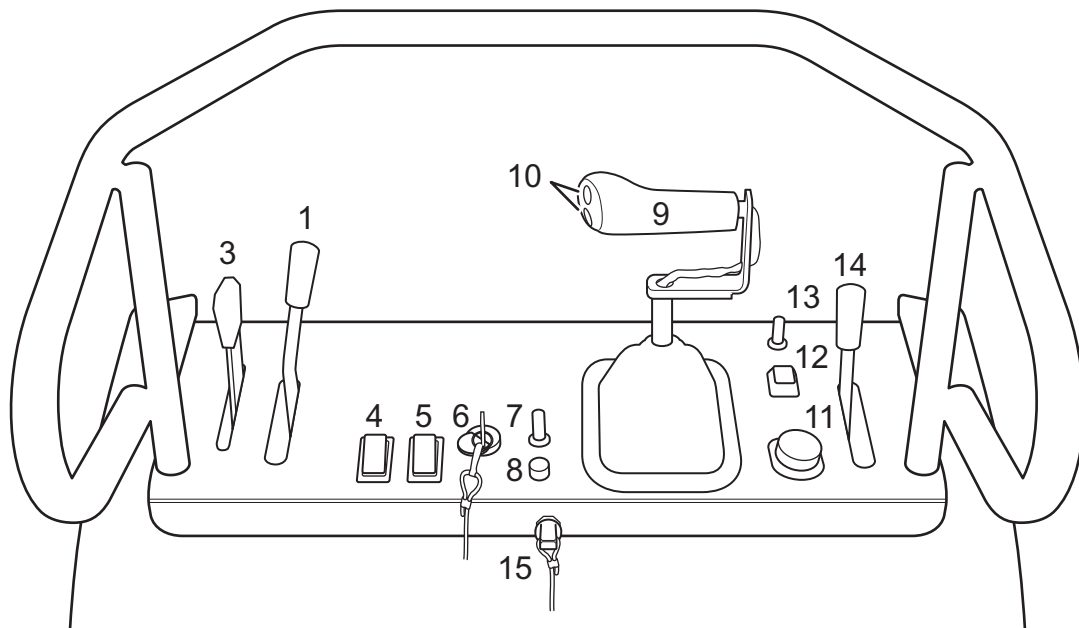

5116M-0201-021E

## 2

# Controls and Components

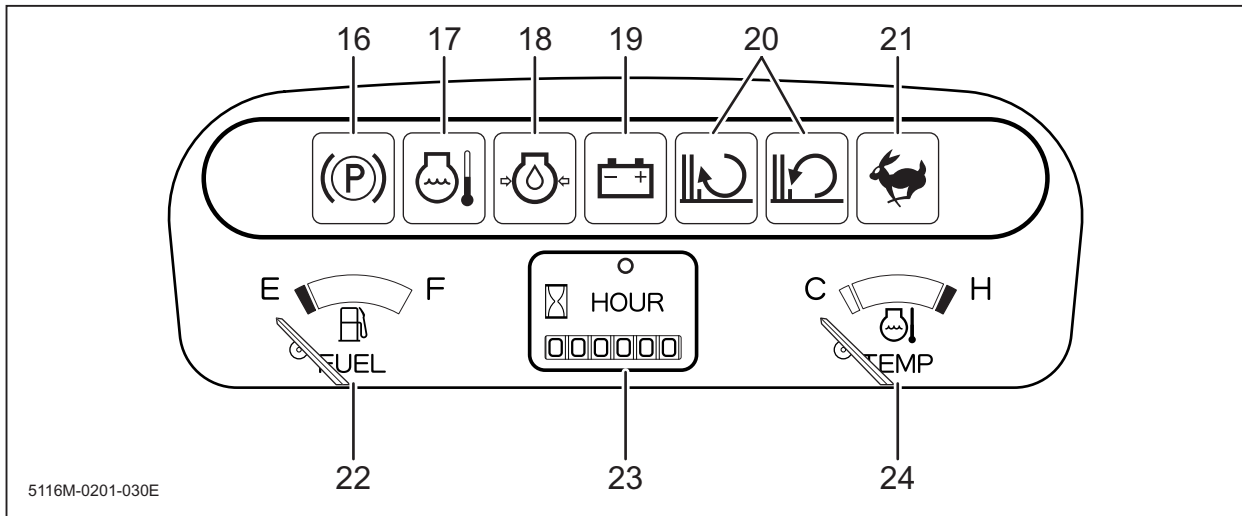

- 5116M-0201-030E
- 1 **Throttle Lever** . . . . . Throttle Lever is used to control engine speed.
  - 2 **Implement Direction Switch** . . . . . Implement direction switch changes the rotating direction of implement.
  - 3 **Implement Direction Lever** . . . . . Implement direction switch changes the rotating direction of implement and adjust revolution speed.
  - 4 **Auxiliary Transmission Switch** . . . . . Auxiliary transmission switch is used to select the auxiliary transmission speed.
  - 5 **Parking Brake Switch** . . . . . Parking brake switch is used to engage parking brake.
  - 6 **Main Switch** . . . . . Main Switch is used to start or stop engine.
  - 7 **Implement Translation Switch** . . . . . Implement translation switch is used to move implement sideways.
  - 8 **Horn Button** . . . . . Pressing this button sounds horn. Use this for warning during traveling or signaling during operation.
  - 9 **Control Stick**. . . . . Control Stick is used to control the traveling direction (forward or backward) and speed of machine.
  - 10 **Implement Lift Switch** . . . . . Implement lift switch is used to lift or lower implement.
  - 11 **Implement Switch**. . . . . Implement switch is used to start or stop implement.

- 
- 12 Automatic Step Levelling Switch** . Automatic step levelling switch turns on or off automatic leveling function of step.
- 13 Manual Step Levelling Switch** . . . . Manual step levelling switch is used to level step manually.
- 14 Implement Height Lever** . . . . . Implement height lever is used to set the minimum height of implement.
- 15 Safety Switch** . . . . . Machine stops if safety plug is detached.
- 16 Parking Brake Indicator** . . . Parking brake indicator lights when parking brake is engaged.
- 17 Coolant Temperature Warning Lamp** . . . . . Coolant teperature warning lamp lights up when coolant temperature is beyond normal operating range (overheating).
- 18 Oil Pressure Warning Lamp** . . . Oil pressure warning lamp indicates if oil pressure is normal. Under normal condition, it goes off when engine starts.
- 19 Charge Lamp** . . . . . Charge lamp indicates the condition of battery charge system. Under normal condition, it goes off when engine starts.
- 20 Implement Indicator** . . . . . Implement indicator lamp lights up when implement is rotating. It also indicates the rotating direction.
- 21 Auxiliary Transmission Lamp** . . Auxiliary transmission indicator lights up when auxiliary transmission is in [  (fast)] mode.
- 22 Fuel Gauge** . . . . . Fuel gauge indicates the fuel level.
- 23 Hour Meter** . . . . . Hour Meter displays and records the total amount of time machine has been in use, in the unit of 0.1 hour.
- 24 Coolant Temperature Meter** . . . . . Coolant temperature meter displays the coolant temperature.
-

## Product Specifications

**⚠ CAUTION!**

· Understand the specifications of this product thoroughly before use.

Model and Type			CG431
Machine Mass		kg	2000
Dimensions	Overall Length	mm	3465
	Overall Width	mm	1700
	Overall Height	mm	1405
	Track Contact Length	mm	1345
	Track Gauge	mm	1170
	Track Width	mm	320
	Ground Clearance	mm	280
	Average Ground Pressure	kgf/cm <sup>2</sup>	0.24
Engine	Model		Kubota V2203
	Type		Water-cooled 4-cycle Diesel, in-line 4 cylinder
	Cylinder (Bore×Stroke)	mm	87X92.4
	Displacement	cm <sup>3</sup> (cc)	2197 (2197)
	Rated Output	kw(PS)/rpm	33.0(44.8)/2600
	Maximum Torque	N·m(kgf·m)/rpm	145.1(14.8)/1500
	Starter System		Electric
	Fuel		Diesel Fuel
	Fuel Consumption	g/kW·h(g/PS·h)	255(190)
	Fuel Tank Capacity	L	52
	Oil Capacity	L	9.7
	Coolant Capacity	L	8.5
Elect.	Battery Type		100E41R
	Battery Capacity		V/AH 12/80
Performance	Speed	FWD HI	km/h 0 - 9
		FWD LO	km/h 0 - 6
		REV HI	km/h 0 - 7
		REV LO	km/h 0 - 4.5
	Minimum Turning Radius		m 2.0
	Gradeability		Degrees 35
	Stability Angle	Left	Degrees 40
Right		Degrees 40	

<b>Model and Type</b>			<b>CG431</b>
Drive Train	Main Transmission		HST (2 Speed Motor)
	Steering		Twin HST
	Transmission Oil Capacity	L	42
	Brakes		Hydraulic

\*These specifications are subject to change without notice.

## Contents of Tool Bag

No.	Content	Quantity	Note
1	Operator's Manual	1	This Manual
2	Operator's Manual for Engine	1	
3	Fire Extinguisher	1	
4	Operator's Manual for Extinguisher	1	



## Preparation

### Pre-start up Inspection

Always perform an inspection before use.

Refer to **Maintenance Schedule** (page 34) for the inspection schedule and procedure.

### Checking and Filling Fuel

#### **⚠ WARNING!**

- Keep fire and spark away when handling fuel.
- Always stop engine before refueling.
- Do not fill beyond the limit (bottom of filler filter) so that fuel will not overflow. In case fuel is spilt, wipe out immediately.

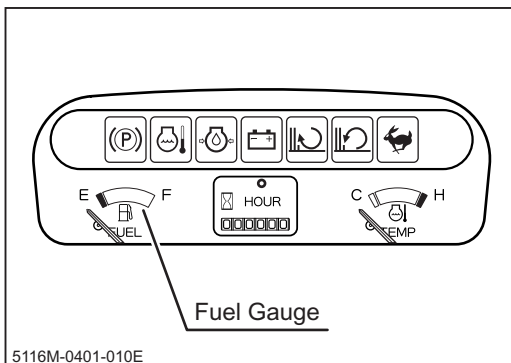

1. Check fuel gauge. If fuel level is low, fill fuel.

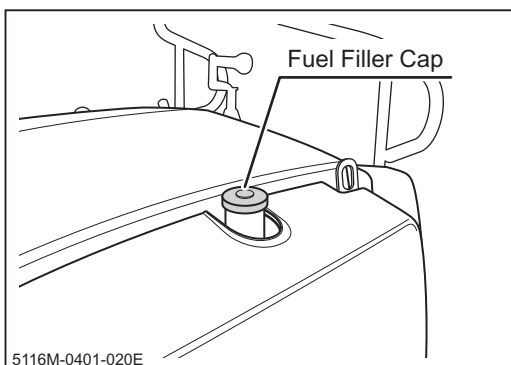

2. Open fuel filler cap to fill fuel.
3. Replace filler cap back in place and close it securely.

#### **NOTE**

- Fuel capacity and kind: Page 39

## Unfolding/Folding Step

### **⚠ WARNING!**

- Hold step firmly when folding or unfolding step. Make certain that hands or fingers are not in the way to be caught by step when folding or unfolding.
- Make certain that step is securely locked with stopper in either position.

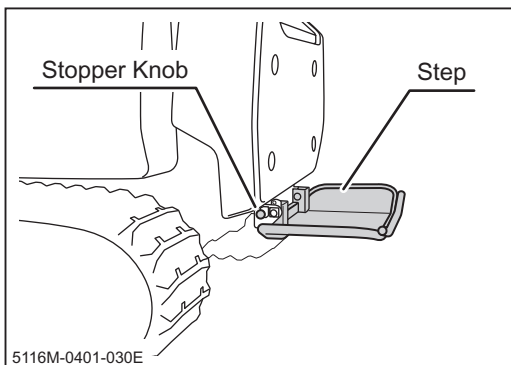

### **Unfolding Step**

1. Hold step firmly and pull stopper knob.
2. Unfold step. Once step is fully unfolded, release stopper knob so that step locks in this position.

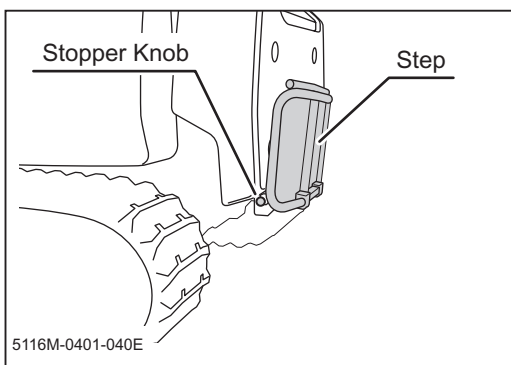

### **Folding Step**

1. Pull stopper knob and fold step.
2. Once step is fully folded, release stopper knob so that step locks in this position.



## Driving

### Starting

#### **⚠ WARNING!**

- Always start and run engine in a well ventilated place.
- Always make certain of the safety of your surroundings when starting engine. Always unfold step and stand on step when starting engine to avoid accident.
- Do not open engine cover while engine is running. An engine that has been running is very hot. Avoid touching engine and its ancillaries, or severe burns may result.
- Always attach string on safety switch to your body so machine stop if you fall off machine.

#### **⚠ CAUTION!**

- Do not turn main switch to [  (start)] when engine is running. Starter motor and/or engine may be damaged.
- Do not turn starter for more than 15 seconds. If engine does not start, turn main switch back to [  (off)] and wait for 30 seconds or more before attempting to start again.
- Do not use this machine in temperatures above 40°C or below -15°C. This machine cannot perform adequately in these temperature ranges. Using this machine under such conditions may result in an accident or cause damage to the machine.
- In the winter or cold climate, warm up engine thoroughly before driving machine. A cold engine delivers poor performance, which may result in an accident. It also causes excessive wear.

## ⚠ CAUTION!

- Do not use this product in dusty places such as desert. Dust may clog air cleaner or enter engine, which may result in loss of performance and an accident. It also causes excessive wear.
- Do not use this machine in the altitude above 1500m in its original configuration. This machine cannot perform adequately above that altitude. Using this machine under such conditions may result in an accident or cause damage to the machine. If you need to use this machine above that altitude, contact your CANYCOM representative.

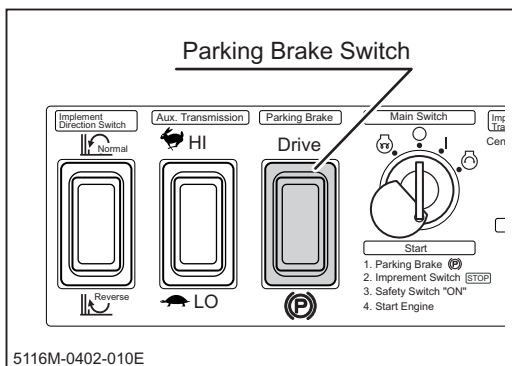

1. Make sure parking brake switch is in [ **(P)** (Parking) ] position.

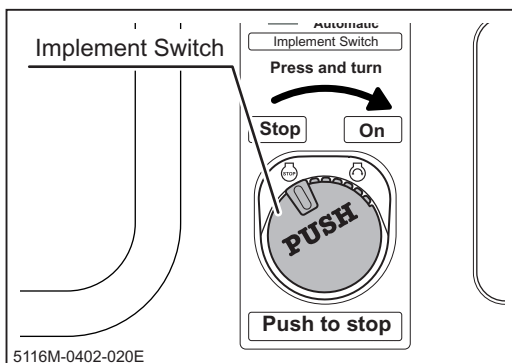

2. Make sure implement switch is in Stop position.

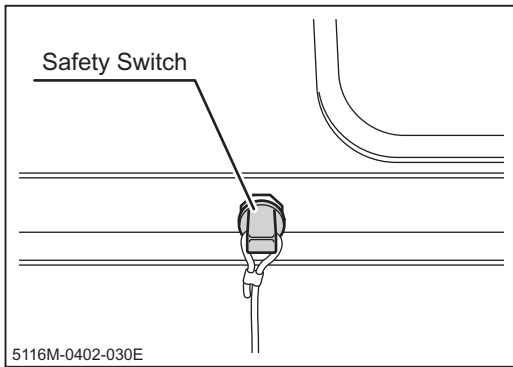

3. Make certain safety switch plug is attached.  
Tie its string to your body.

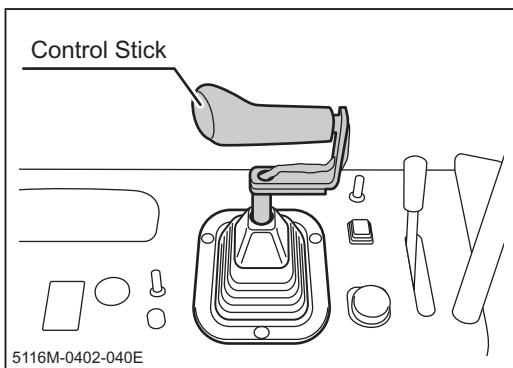

4. Make sure control stick is in neutral position.

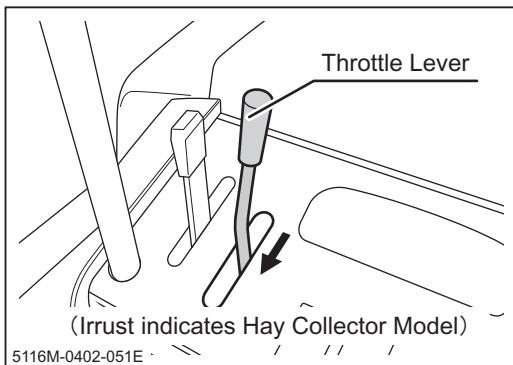

5. Move throttle lever slightly toward [👉(fast)].

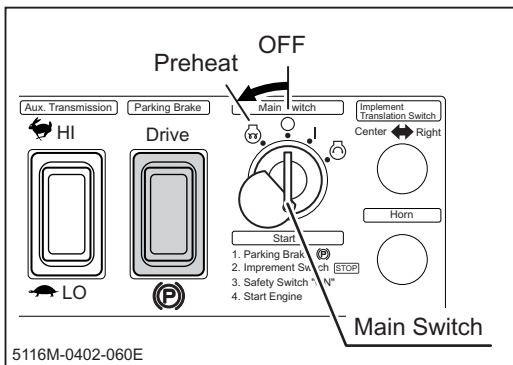

6. Turn main switch to [👈(preheat)] position.

## NOTE

- Preheat engine for about 10 seconds when starting in normal temperature and for about 20 to 30 seconds when starting in cold weather (ambient temperature below -5 °C).
- There is no need to preheat if engine is already warm.

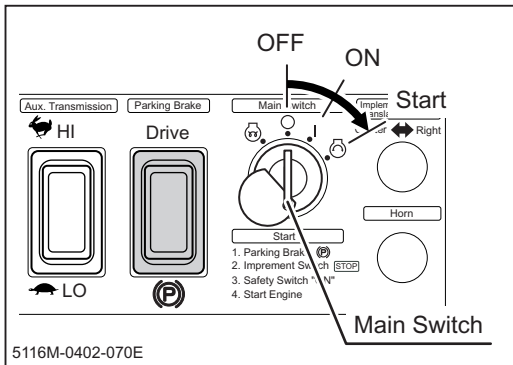

- Turn main switch to [  (start)] position to start engine. Once engine starts, release key immediately; switch will automatically return to [ | (on)] position.

## NOTE

- **Avoid frequent starting. Once engine starts, run it for a while to charge battery.**

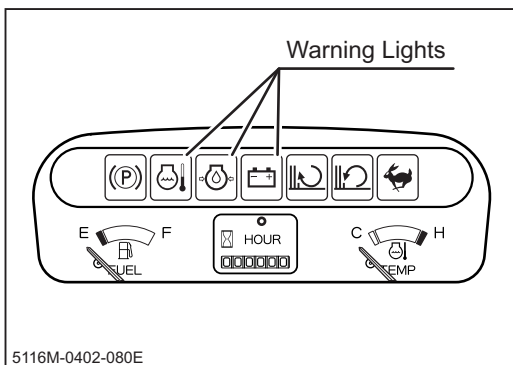

- Make certain warning lamps (coolant temp., oil pressure, charge lamp) are not lit. If any of them remain lit, refer to **Troubleshooting** (page 71) and take an appropriate measure.
- Allow engine to warm up by running it for about 5 minutes without any load.

## NOTE

- **Drive machine gently in the first 40 to 50 hours of use after purchase for breaking-in.**

## Driving

**⚠ WARNING!**

- Do not allow bystanders to come near machine when driving.
- Always make certain of the safety of your surroundings before driving; start slow.
- Always make certain of the safety of your surroundings before turning.
- Do not make sudden starts, acceleration, change of speed, change of direction, or stop. Do not turn at speed. Avoid sudden maneuvers; this may cause operator to fall or to be thrown, or machine to tip over.
- Do not turn parking brake switch to [(P) (parking)] or turn main switch to [O (off)] position while traveling. Machine can lose stability and tip over.
- Always stand on step when traveling on machine. Never operate control stick off of machine. This may cause machine to run over or crush operator.
- Always move the steering levers back to the neutral position before releasing. Letting it go from other operating positions may result in sudden deceleration and can cause machine to tip over or operator to fall or to be thrown.

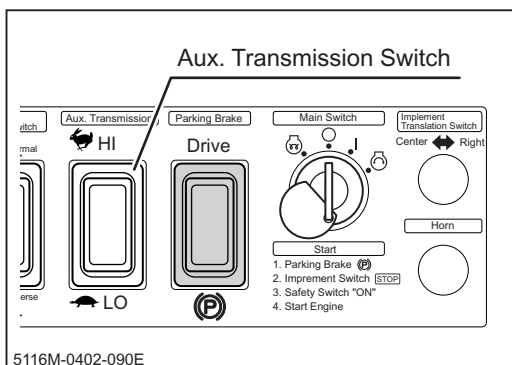

1. Make certain of the safety of your surroundings.
2. Set auxiliary transmission switch to a desired position.

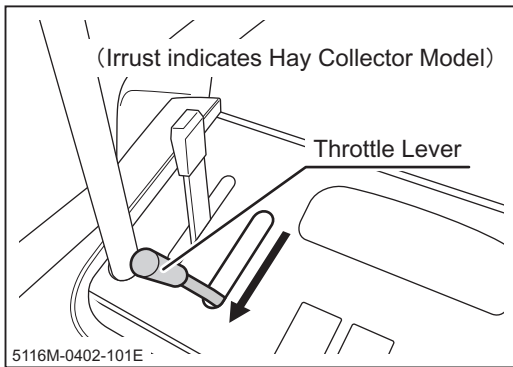

3. Move throttle lever toward [  (fast)] position to increase engine speed.

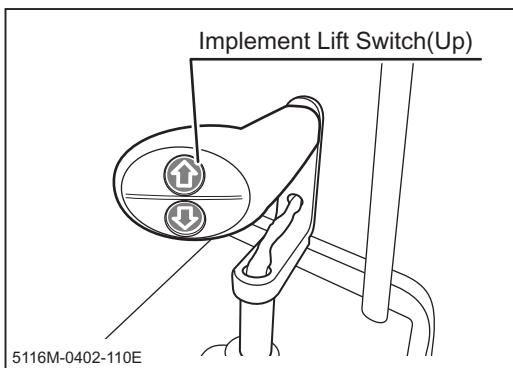

4. Press implement lift switch [UP] to lift implement off the ground.

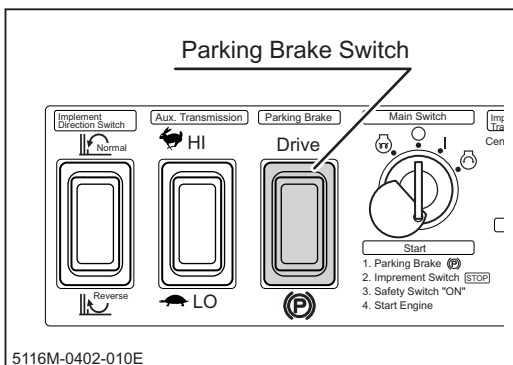

5. Turn parking brake switch to [RUN].

## NOTE

- If parking brake switch is in [ (P) (parking)] position, machine does not move even when control stick is operated.

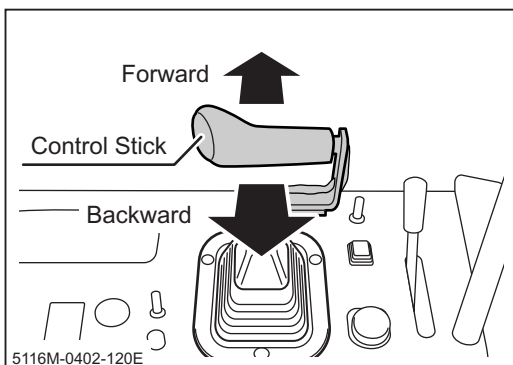

## Moving Forward/Backward

6. Move control stick gradually forward to move machine forward, or move it backward to travel backward. The angle of control stick controls the machine speed.



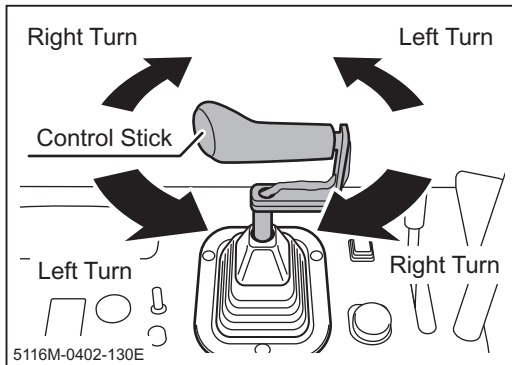

## Turning

- Twist control stick gradually to a desired direction. Machine turns to the corresponding direction. Turning radius can be controlled by the amount of twisting. Twisting control stick in the neutral position makes machine spin-turn on the spot.

## Stopping

### **⚠ WARNING!**

- Do not make a sudden stop. Machine may skid or tip over.
- Do not release steering levers suddenly. Machine may stop suddenly and skid or tip over.
- Always park on a firm, level place. Never park on a potentially dangerous place.
- Avoid parking on a slope. Never park on a slope with an incline of 15 degrees or steeper. If it is absolutely necessary to park machine on a slope less than 15 degrees, make certain to apply parking brake firmly and block the tracks with chocks.

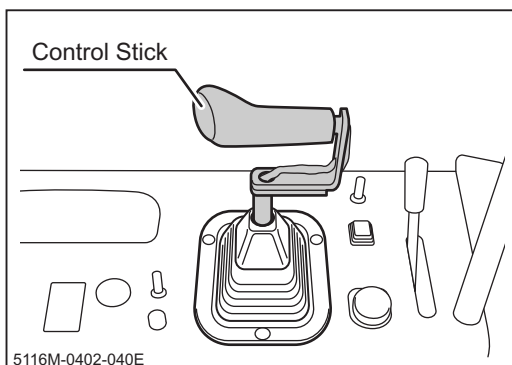

- Move control stick gradually to the neutral position.

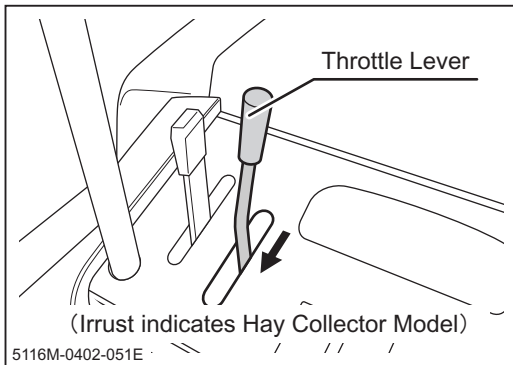

2. Move throttle lever to [  (slow)] to decrease engine speed.

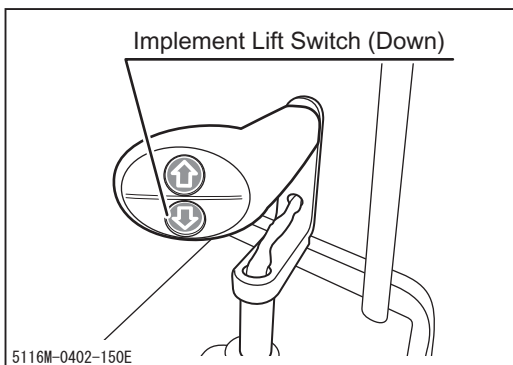

3. Press implement lift switch [DOWN] to lower implement until it touches the ground.

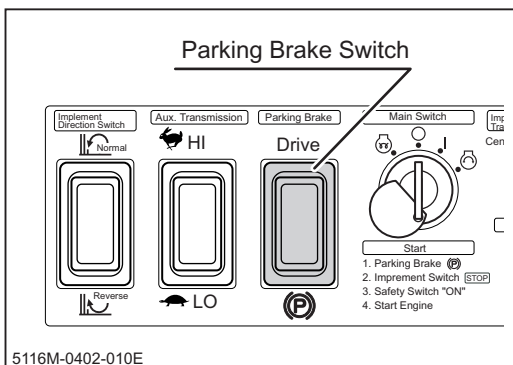

4. Turn parking brake switch to [  (parking)] position.

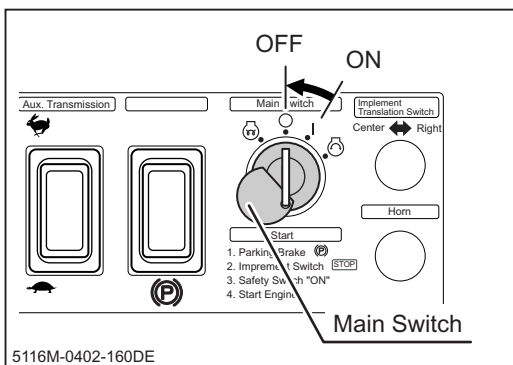

5. Turn main switch to [  (OFF)] position to stop engine.
6. Remove key.

## Working

### **⚠ DANGER!**

- Never place any part of body under implement when implement is running. See implement's manual for safe use.

### **⚠ WARNING!**

- Always tie string on safety switch to operator's body so that machine stops when operator falls off machine.
- Do not allow bystanders to come near machine when working.
- Running implement can throw stones or debris and cause injuries and damages to nearby people, animals, crops, buildings, automobiles, etc. Pay attention to the safety of surroundings and plan ahead when working.
- Never attempt to work with implement's shield open (if applicable).
- When working, drive forward. Machine is intended to perform the intended job while moving forward, and this best prevents stones and debris from being thrown.
- Turn implement switch to [ON] only when working. Keep it in [OFF] position all the other times.
- Never attempt to work brush on or near the edge of a ditch or bank. Shoulder of a ditch or bank may collapse. Pay extra care after heavy rain or earthquake.
- Inspect the work site beforehand; inspect terrain and locate holes, drops, or obstacles. Also inspect overhead obstacles such as branches of a tree. Pay special attention when working near these areas.
- Only skilled operator is allowed to use this machine under difficult circumstances.

## ⚠ CAUTION!

- Do not use this machine on an incline steeper than 30 degrees.
- Always use [🐢 (Slow)] mode when working.
- Do not turn on an incline, or machine can tip over.
- Do not work on a slippery surface.
- When working in a dusty area, clean air cleaner element twice a day. Dirty air cleaner element results in poor starting, poor performance, or short life.
- When something is tangled to implement, stop engine immediately and remove the tangled object. Such object causes excessive vibration or load, which damages machine.

## Operating Implement

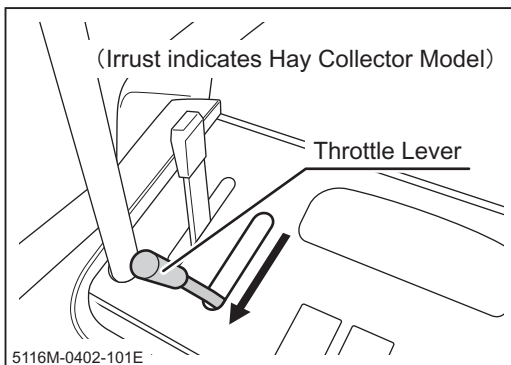

1. Move throttle lever to [🐇 (fast)] position to increase engine speed.

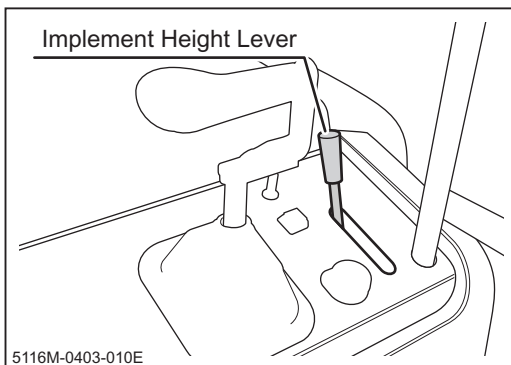

2. Use implement height lever to set the desired cutting height.

### NOTE

- Implement height lever sets the height to which implement can be lowered.

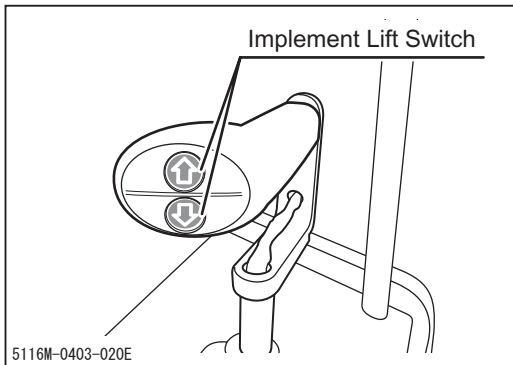

- Use implement lift switch to adjust the implement height.

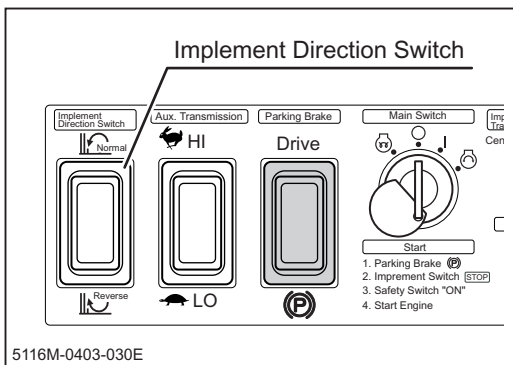

- Use rotation direction switch to choose the direction of implement rotation.

**NOTE**

- Reverse rotation can be used only when implement is not translated to the side. If implement is translated and rotation direction switch is in reverse, implement stops.
- When something gets tangled to implement, changing the rotating direction back and forth may help untangle.

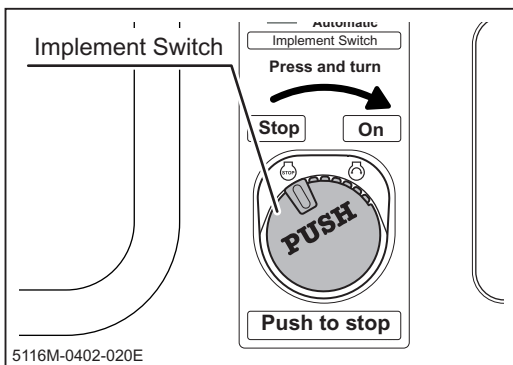

- Push and turn implement switch to [RUN].
- Drive machine forward to cut.

**NOTE**

- If load is high, reduce traveling speed or work in stages at different cutting heights.

- To stop implement, press implement switch; it automatically returns to [stop].

## Changing PTO Speed (Variable PTO Speed Model Only)

On Variable Speed PTO model, the PTO speed can be varied to meet requirements for different implements.

### **⚠ CAUTION!**

- Use only the implements that are specifically designed and certified for this machine.
- Refer to the instructions for the specific implement.

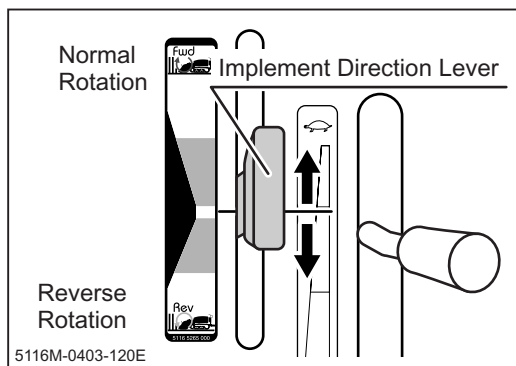

1. Move throttle lever to adjust engine speed.
2. Move implement direction lever to adjust the speed and direction of implement.

## Translating Implement

With this translation function, the entire implement can be translated to the right by 500mm at the maximum, allowing working on the edge of ditch or bank.

### ⚠ CAUTION!

- Always make certain of the safety of your surroundings before translating implement.
- Always lift up implement when translating. Translating implement while it is resting on the ground may cause damage.

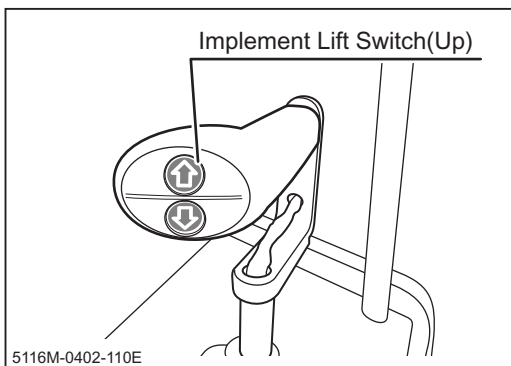

1. Press implement lift switch [UP] to lift implement off the ground.

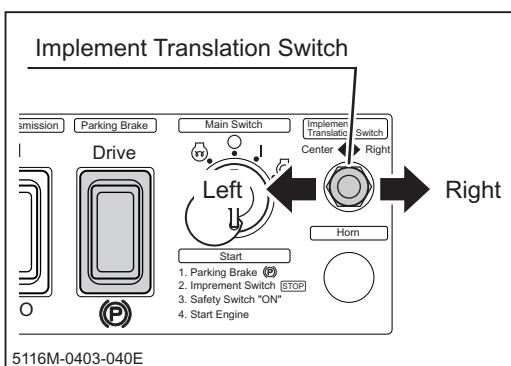

2. Tilt implement translation switch to [Right] to move implement to the right.
3. Tilt translation switch to [Center] to move it back to the original position.

### NOTE

- Implement does not translate when it is running.
- When rotating direction is set in reverse, implement can only translate to 100mm to the right.
- When implement is translated and then direction switch is set in reverse, implement does not run.

## Levelling Step

Step levelling turns step relative to machine to keep it horizontal and provide stable work platform for the operator.

### ⚠ CAUTION!

- Under normal condition, keep step levelling to [AUTO].
- Pinch hazard: beware of pinch spots when levelling step manually. Keep fingers or hands away of pinch spots.

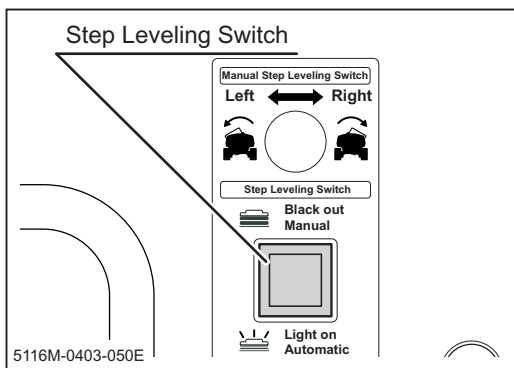

1. Automatic step levelling switch activates or deactivates automatic step levelling function. When activated, switch illuminates.

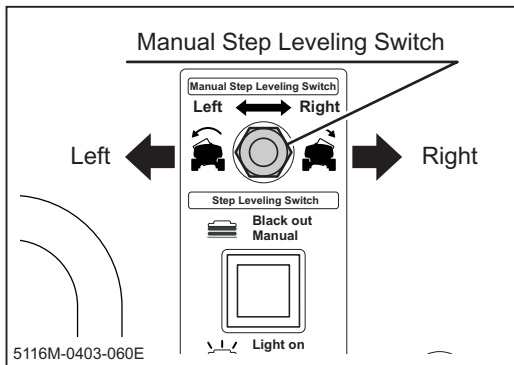

### Manual Levelling

2. When automatic levelling is deactivated, tilting manual leveling switch to the right turns step to the right (clockwise, as seen from behind), and tilting it to the left turns step to the left (counter-clockwise).



## Hydraulic Cooling Fan

Hydraulic cooling fan automatically reverses at a certain interval to prevent clogging of radiator. It has three operation modes to suite different conditions.

### ⚠ CAUTION!

- Do not set mode to [1] when working. It may cause overheating.

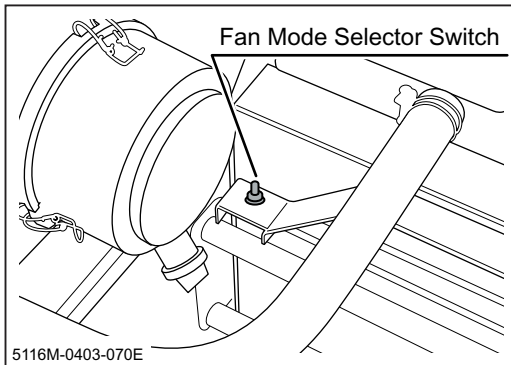

1. Open top cover and hold it securely with prop (Page 43).
2. Set fan mode selector switch to select an appropriate mode for the desired operation.

Hydraulic Fan Control Mode Switching	
Mode	Usage
1	Cleaning (Do not use when working)
2	Normal Use
3	Working in dusty area

5116 5238 000

5116M-0403-080E

3. Select mode [2] for normal operation.
4. Select mode [3] for working in a dusty area.
5. Select mode [1] when cleaning radiator. Set switch back to [2] or [3] when cleaning is done.

### NOTE

- Mode [1] is for blowing off relatively large debris on site. For small debris in radiator fins, clean with compressed air regularly.

## Fire Extinguisher

### **⚠ CAUTION!**

- Read and understand the attached Fire Extinguisher Operator's Manual thoroughly before use.

### Fire Extinguisher Location

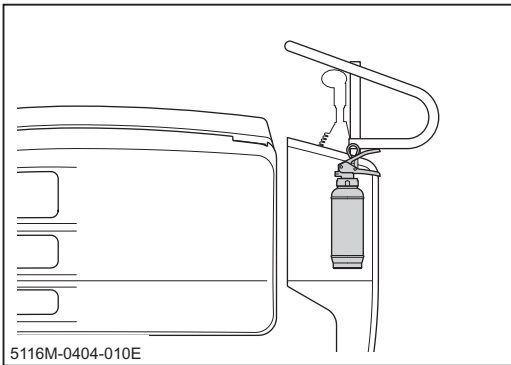

1. Fire extinguisher is attached on the left side of controls cover.

### Using Fire Extinguisher

Refer to the fire extinguisher operator's manual for its use.

## Maintenance Schedule

**⚠️ WARNING!**

- Follow the scheduled maintenance as described below. Failure to do so may result in mechanical or property damage, injury or death.

- Perform a pre-startup inspection (PSI) before each use, a monthly inspection once a month, and a yearly inspection once a year.
- Some maintenance procedures described below may require special knowledge or tools and instruments. Contact your CANYCOM representative to perform such procedures.

Item	Description	Schedule			Note	
		PSI	Mon	Year		
Engine General	Starting	Engine shall start easily without making any irregular noise.	√	√	√	
		Glow plugs work correctly.	√	√	√	
	Running	Engine speed shall be set properly at idle and at full without load. Engine shall stay running smoothly.		√	√	Contact your CANYCOM representative for inspection.
		When accelerating engine, throttle lever shall move smoothly, and engine shall accelerate smoothly without stopping or knocking.	√	√	√	
	Exhaust	Warm up engine thoroughly, and observe exhaust sound and gas from idle to fast speed; exhaust sound shall be normal and smoke shall not be excessive.	√	√	√	
		There shall be no leak in exhaust system or muffler.		√	√	
	Air Cleaner	Air cleaner case shall not be deformed or cracked. Case lid and connecting air hose shall be firmly in place.		√	√	
		Cleaner elements shall be in good shape without damage or excessive dust.	√	√	√	Cleaning/Replacing: Page 50
	Fasteners	Bolts and nuts fastening cylinder head, intake and exhaust manifolds shall be tightly fastened. * this may be skipped if there is no gas or water leaks found in these areas.			√	

Item		Description	Schedule			Note
			PSI	Mon	Year	
Engine	General	Compression			√	Contact your CANYCOM representative for inspection.
		Engine Mount			√	
	Lubrication System	Engine base shall be free of cracks or deformation.			√	
		Mounting bolts and nuts shall not be loose or missing.			√	
		Oil shall be clean and at correct level.	√	√	√	Inspecting/Changing: Page 45
	Fuel System	No noticable oil leaks shall be found in head cover, oil pan, or pipes.	√	√	√	
		Oil filter shall not be excessively dirty or damaged			√	Changing: Page 45
	Cooling System	There shall not be any leaks in fuel tank, injection pump, hoses, or pipes.	√	√	√	
		Fuel hoses shall be free of damage or deterioration.	√	√	√	
		Fuel filter shall not be excessively dirty or clogged.		√	√	Cleaning: Page 53
		Injection puessure and injection condition from the nozzle shall be normal. * this may be skipped if running and exhaust condition is normal at idle and under acceleration.			√	Contact your CANYCOM representative for inspection.
		There shall not be sediment or water in fuel tank.		√	√	Cleaning: Page 52
	Cooling System	Coolant shall be clean and at the correct level.	√	√	√	Inspecting/Filling: Page 47
		There shall not be any leaks from radiator, engine, water pump, or hoses.	√	√	√	
		Radiator fins shall be free of clogging.	√	√	√	
		Hoses shall be free of damage or deterioration.	√	√	√	
		Radiator cap valve shall function properly.			√	
		Valve seat of radiator cap shall be free of damage.			√	
		Fan belt shall be properly tensioned.			√	Inspecting/Adjusting: Page 51
	Fan belt shall be free of wear and damage.			√		

Item	Description	Schedule			Note		
		PSI	Mon	Year			
Engine	Cooling System	Cooling fan, duct, and cover shall be free of cracks, damage, or deformation.			√		
		Mounting bolts and nuts on cooling fan, duct, and covers shall not be loose or missing.			√		
	Electrical System	Charge System	Charge system is working correctly.			√	Contact your CANYCOM representative for inspection.
		Battery	Battery electrolyte level shall be correct.		√	√	Inspecting/Filling: Page 62
	Terminals shall be free of marked corrosion and are tightly secured.			√	√		
	Wiring	Connections shall be securely connected.		√	√		
		Wiring shall be free of damages.		√	√		
Drive Train	HST Pump	Drive the machine forward and backward, turn left and right in both directions; machine shall move normally and free of irregular noise or overheating.	√	√	√		
		Hydraulic fluid shall be filled to a proper level, clean and free of dirt or contamination.	√	√	√	Inspecting/Changing: Page 54	
		There shall be no fluid leaks in or around fluid tank.			√		
Undercarriage	Wheels Sprockets Idlers	Shall be free of cracks, defromation, or excessive wear.	√	√	√		
		Irregular noise or overheating shall not be observed from axles when traveling.	√	√	√		
		Mounting bolt or nut shall not be loose or missing.	√	√	√		
		There shall be no oil leak in or around axle.	√	√	√		
		Roller swings shall follow terrain smoothly when running.			√		
		Shall be sufficiently lubricated.		√	√	Lubricating: Page 60	
	Tracks	Steel cord shall not be cut or markedly damaged.	√	√	√		
		Rubber shall not be markedly cut, deteriorated, or worn.	√	√	√		
		Track core shall not be missing or damaged.	√	√	√		
		Track shall be properly tensioned; shall not be too loose or too tight.			√	Adjusting: Page 58	

Item	Description	Schedule			Note
		PSI	Mon	Year	
<b>Undercarriage</b>	<b>Track Adjuster</b>	Track adjuster shall work normally when filled with a proper amount of grease.			
	<b>Track Frame</b>	There shall not be cracks, deformation, damage, or excessive wear on wear parts. In case of a possible crack, use flaw detector to check.			
		Mounting bolts and nuts shall not be loose or missing.			
<b>Brake</b>	<b>Parking Brake</b>	Parking brake shall be able to hold the machine on a 20-degree slope.			
<b>Hydraulic System</b>	<b>Hydraulic Pump</b>	There shall be no leak in or around joints or seals between hydraulic pump and pipes or hoses.			
		No irregular vibration, noise, or heat shall be observed when hydraulic pump is in operation.			
		Amount and pressure of discharge under load shall be within the standard range specified by the manufacturer. *this may be skipped if irregular vibration, noise, or heat described above is not observed.			
	<b>Plumbing</b>	Plumbing shall be free of cracks, damage, twists, or deterioration.			
		There shall be no leaks in pipes, hoses, joints, or seals.			
		Plumbing shall be mounted properly, and fastening bolts and nuts shall not be loose or missing.			
	<b>Hydraulic Cylinders</b>	Shall work smoothly.			
		There shall be no leaks when extending or contracting cylinder.			
		Extend hydraulic cylinder fully under load and hold. Stroke shall be within the range specified by manufacturer.			
		Cylinder tube and rod shall be free of dents, cracks, bends, or scratches.			
		Cylinder mounting pins shall be free of damage or excessive wear.			

Item	Description	Schedule			Note	
		PSI	Mon	Year		
Hydraulic System	Control Valve	Shall be firmly and properly mounted.	√	√		
		When a valve is operated, its corresponding cylinder shall move accordingly. when		√	√	
		There shall be no leaks in pipes, hoses, joints, or seals.		√	√	
Body, Chassis, Safety Devices	Chassis Frame	Shall be free of cracks, deformation, or corrosion.		√	√	
		Fastening bolts or nuts shall not be loose or missing.	√	√	√	
	Body Panels	Shall be free of cracks or deformation.		√	√	
		Doors or lids shall open and close, and lock shall lock properly.		√	√	
		Fastening bolts or nuts shall not be loose or missing.	√	√	√	
	Step	Shall fold, unfold, and lock properly.	√	√	√	
	Labels	Warning labels and instruction plates shall be clean, legible, and free of damage.	√	√	√	
	Instruments	Instruments shall work properly while engine is running.	√	√	√	
	Horn	Horn shall work.	√	√	√	
	Rotor Indicator	Rotor indicator shall illuminate when rotor is running.	√	√	√	

## List of Fluids and Lubricants

Item	Schedule	Grade	Cap.
Fuel	As needed.	Diesel Fuel	52L
Engine Oil	Fill Inspect daily. Fill as needed. Change Initially - After 50 hours of use. Every 200 hours afterwards.	Diesel Engine Oil API rating: CD or better. SAE rating: 10W-30	9.7L
HST Fluid (doubles as hydraulic fluid)	Change Initially - After 500 hours of use. Every 1000 hours afterwards.	High viscosity index hydraulic fluid, ISO VG46 or Diesel engine Oil API rating: CD or better. SAE rating: 10W-30 *When using in cold climate (below -15°C), use ISO VG32 anti-wear hydraulic fluid.	42L
Drive Motor Lubricant	Change Initially - After 200 hours. Every 1000 hours afterwards.	Gear Oil API rating: GL-4 SAE rating: #90	0.6L
Grease	Every 100 hours.	Lithium all-purpose grease (NLG No.2 or equivalent)	-
Engine Coolant	Fill as needed Change every 300 hours.	Long Life Coolant (LLC) and pure water Mixture	8.5L (Not including reservoir)
Battery Electrolyte	Check every 50 hours. Fill as needed.	Distilled Water	-



Grease Points

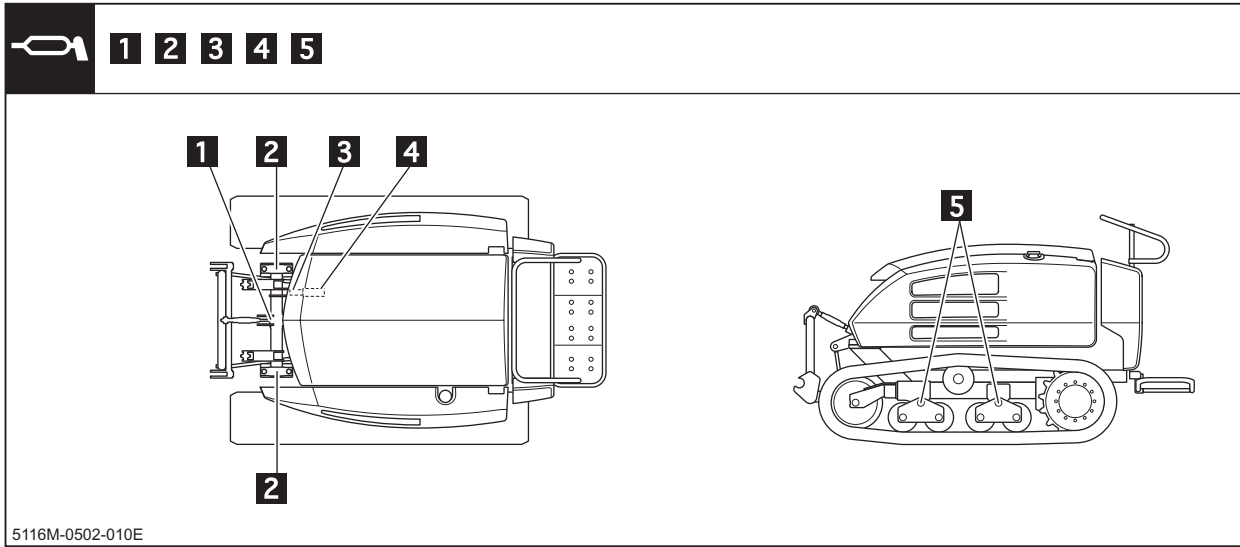

List of Consumables and Spares

**⚠ CAUTION!**

- Use only CANYCOM genuine parts when replacement or repair is required. CANYCOM assumes no liability whatsoever if any problem occurs as a result of using any part that is not a genuine CANYCOM part.

Item	Part No.	Schedule	Qty.
<b>Engine</b>			
Engine Oil Filter Cartridge	36610001300	Every 400 hours (Initially: after 50 hours)	1
Hoses (Radiator)	51160321001	Every 2 years or if defective.	1
	51160325000	Every 2 years or if defective.	1
	51160327001	Every 2 years or if defective.	1
	51160357000	Every 2 years or if defective.	1
Hoses (Hydraulic Fan)	51166041000	Every 2 years or if defective.	1
	51166042000	Every 2 years or if defective.	1
	51166043000	Every 2 years or if defective.	1
Air Cleaner Element (Outer)	R1404-42271	Every 1000 hours or if defective.	1
Air Cleaner Element (Inner)	R2401-42281	Every 1000 hours or if defective.	1
V-Belt (Fan)	IG780-97011	If defective.	1

Item	Part No.	Schedule	Qty.
<b>Fuel System</b>			
Fuel Filter Cartridge	36640221500	Every 500 hours.	1
Hoses (Fuel)	51160531000	Every 2 years or if defective.	1
	51160532000	Every 2 years or if defective.	1
	51160533000	Every 2 years or if defective.	1
	51160534000	Every 2 years or if defective.	1
	51160538000	Every 2 years or if defective.	1
<b>Hydraulic System</b>			
Suction Filter (Cutting Rotor)	51166453000	Every 1000 hours or if defective.	1
Suction Filter (Gear Pump)	51166454000	Every 1000 hours or if defective.	1
Return Filter Element	51166452100	Every 500 hours or if defective.	1
Hose (Oil Tank)	51166462000	Every 2 years or if defective.	1
Hoses (Lift)	51166223000	Every 2 years or if defective.	1
	51166231000	Every 2 years or if defective.	1
	51166251000	Every 2 years or if defective.	1
	51166252000	Every 2 years or if defective.	1
	51166253000	Every 2 years or if defective.	1
	51166254000	Every 2 years or if defective.	1
Hoses (Rotor)	51166343000	Every 2 years or if defective.	2
	51166344000	Every 2 years or if defective.	1
	51166345000	Every 2 years or if defective.	2
	51166346000	Every 2 years or if defective.	1
	51166347000	Every 2 years or if defective.	1
	51166348000	Every 2 years or if defective.	1
<b>Drive Train</b>			
Track	51162106000	If defective.	2
Sprocket 15T	36632106000	If defective.	2
Roller	52292201000	If defective.	8
Return Roller Assy	36402218000	If defective.	2
Idler Assy	36402331000	If defective.	2
Hoses (Drive)	51166131000	Every 2 years or if defective.	2
	51166132000	Every 2 years or if defective.	2
	51166133000	Every 2 years or if defective.	1
	51166134000	Every 2 years or if defective.	1
	51166135000	Every 2 years or if defective.	1
	51166136000	Every 2 years or if defective.	1
	51166137000	Every 2 years or if defective.	1
	51166138000	Every 2 years or if defective.	1
	51166139000	Every 2 years or if defective.	1
51166141000	Every 2 years or if defective.	1	

# 5

# Maintenance

---

Item	Part No.	Schedule	Qty.
Hoses (Drive)	51166142000	Every 2 years or if defective.	1
	51166143000	Every 2 years or if defective.	1
	51166144000	Every 2 years or if defective.	1
<b>Electric System</b>			
Battery 100E41R	36610502000	If defective.	1
Fuse 10A (Red)	09801001004	If defective.	5
Fuse 15A (Blue)	09801001504	If defective.	3
Fuse 20A (Yellow)	09801002003	If defective.	1
Fuse 30A (Green)	09801003003	If defective.	1
Fuse 40A (Green)	09801004003	If defective.	1
Fuse 60A (Yellow)	09801006005	If defective.	2

## NOTE

---

- Rubber products such as the hydraulic hose deteriorate over time. Replace them every 2 years.
- Track wear limit: 5mm of lug height

## Body Panels

### **⚠ WARNING!**

- Do not open engine cover while engine is running.

### **⚠ CAUTION!**

- Cut or pinch hazard exists when removing or installing body panels; beware of sharp edges and pinch points.
- Make certain to reinstall panels and closing doors after removing or opening for repairs or inspection.

## Opening Top Cover

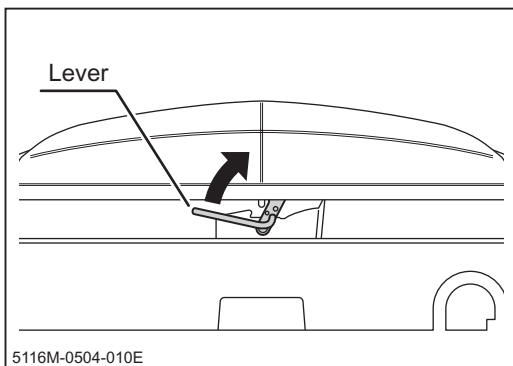

1. Pull up lever to open top cover.

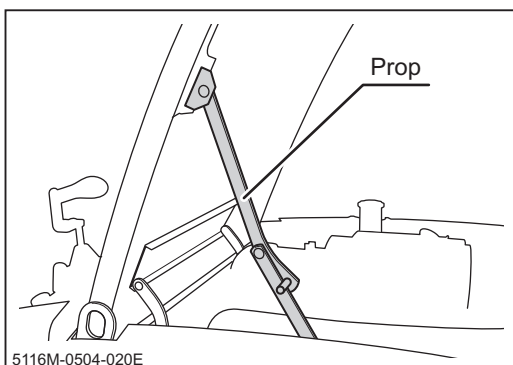

2. Open top cover fully until it stays firmly in that position with prop.

## Removing Side Covers

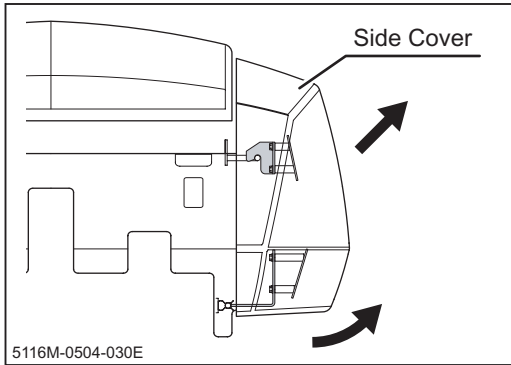

1. Pull lower side of side cover to undo lower catch.
2. Pull side cover up and away from machine to undo upper catch.

## Removing Front Cover

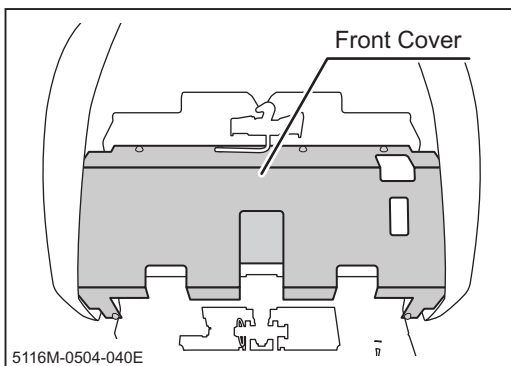

1. Remove side covers on both sides.
2. Undo 6 bolts to remove front cover.

## Removing Controls Cover

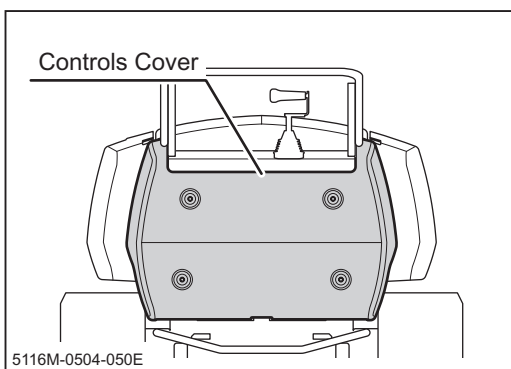

1. Undo 4 bolts
2. Pull controls cover away from machine to remove.

## Engine

### **⚠ WARNING!**

- Always stop engine and remove key before servicing.
- An engine that has been running is very hot. Allow engine to cool before servicing, or severe burns may result.
- Keep fire and spark away when handling fuel.

## Engine Oil

### **⚠ CAUTION!**

- Dispose of drained oil properly.
- Make certain to fill engine with correct grade of oil to the specified level. Insufficient amount or wrong grade of oil reduces performance and may cause permanent damage to engine.

### NOTE

- To obtain correct reading, check oil level before starting, or wait about 10 minutes after stopping engine to allow oil to drain back to oil pan.
- Refer also to the Operator's Manual for the Engine when servicing engine.
- Always check oil level on a level surface.
- Oil capacity and grade: Page 39.

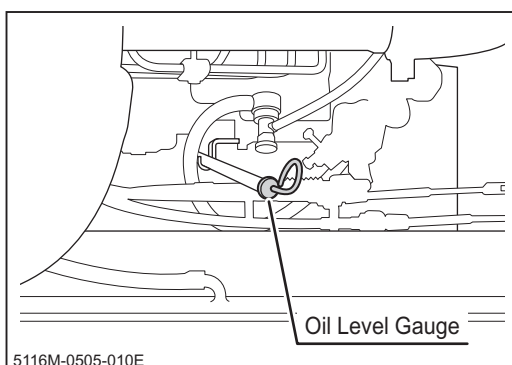

### Inspecting

1. Park machine on a level surface.
2. Open top cover and hold it securely in place with prop.
3. Pull out oil level gauge and wipe off oil. Insert gauge fully and pull it out again.

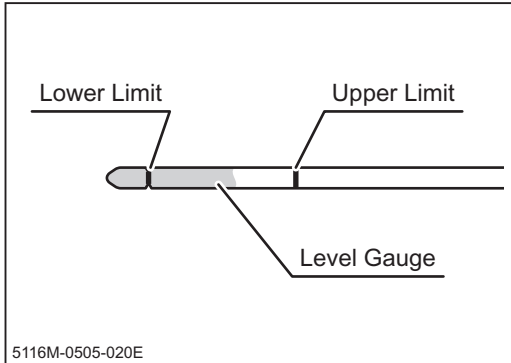

4. Visually check oil level. If it is below lower limit, fill.
5. Visually inspect the condition of oil. If it is dirty or its viscosity is not right, change oil.
6. Install oil level gauge.
7. Close top cover.

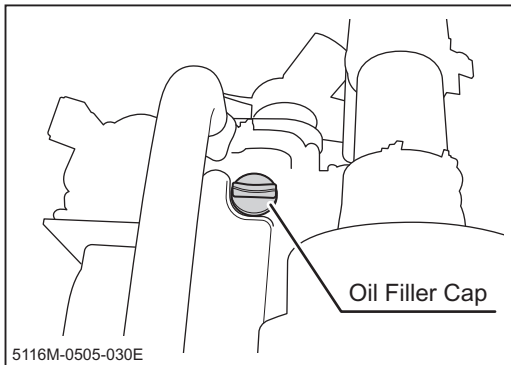

### Filling

1. Open top cover and hold it securely in place with prop.
2. Undo and remove oil filler cap.
3. Fill specified oil into filler.
4. Check oil lever.
5. Replace oil filler cap.
6. Close top cover.

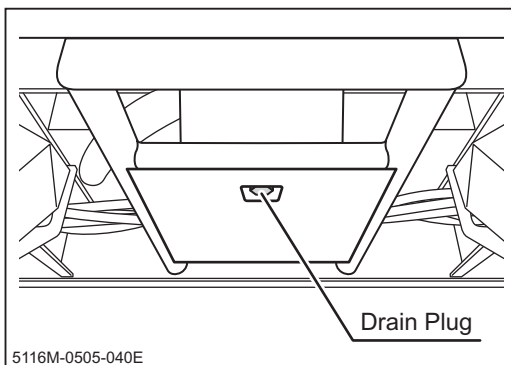

### Changing

1. Have an appropriate oil drain pan.
2. Open top cover and hold it securely in place with prop.
3. Remove filler cap.
4. Remove drain plug to drain oil.
5. Clean drain plug and put it back in place and tighten it securely.
6. Fill oil.
7. Check oil level.
8. Replace filler cap.
9. Close top cover.

## Oil Filter

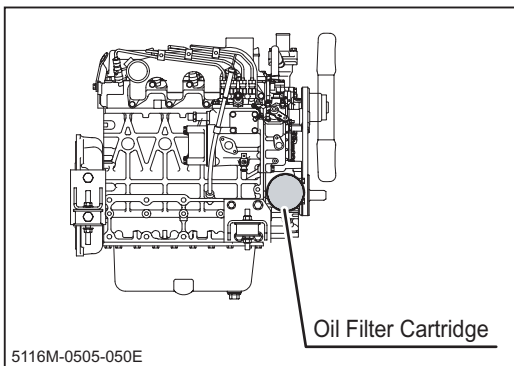

1. Drain oil.
2. Remove oil filter cartridge with filter wrench.
3. Clean filter base on engine.

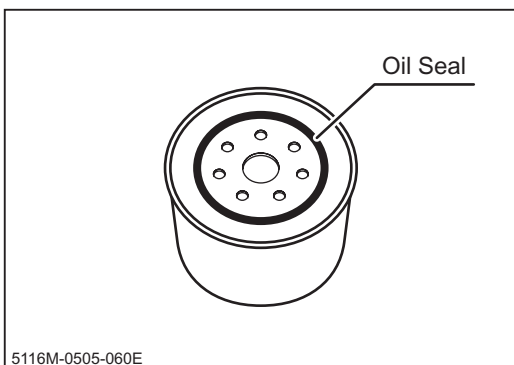

4. Prepare new filter cartridge. Coat its oil seal with fresh engine oil.
5. Install cartridge and tighten it fully with hand.
6. Fill oil.
7. Start engine and make sure there is no leak from filter.

## Coolant

### **⚠ WARNING!**

- Do not open radiator cap when engine or radiator is hot. Opening cap when they are still hot may release boiling coolant and cause severe burns. Wait for engine to cool after operation (about 10 minutes) before opening.
- Take extreme care when handling coolant; antifreeze solution is flammable. Avoid exposure to open flame. It is also toxic. If coolant is caught in the eye, wash the eye clean with running water and consult a physician immediately.



**⚠ CAUTION!**

- Maintain sufficient amount of coolant. Insufficient amount of coolant may cause overheating.
- Dispose of drained coolant properly.

**NOTE**

- Coolant capacity and grade: Page 39.

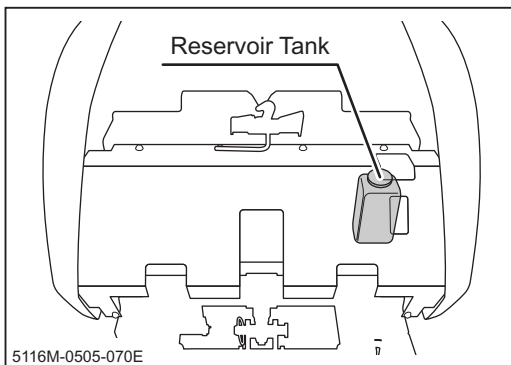
**Inspecting**

1. Park machine on a level surface. Open engine cover.
2. Visually check engine coolant level in reservoir tank. Make sure coolant level is between [LOW] and [FULL] lines.
3. If level is below [LOW] mark, fill water.

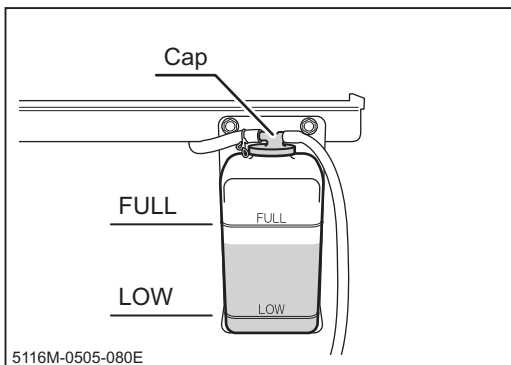
**Filling**

1. Open top cover and hold it securely in place with prop.
2. Remove cap and fill coolant to [FULL] line.
3. Replace cap.
4. Close top cover.

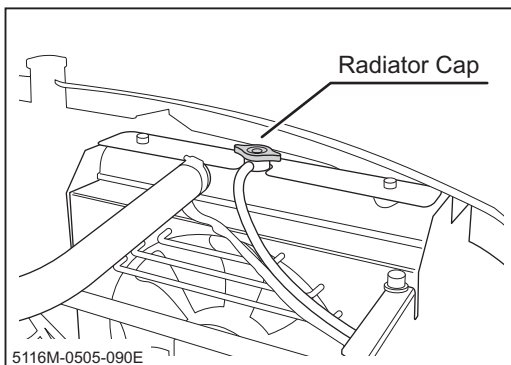
**Changing**

1. Have an appropriate drain pan.
2. Open top cover and hold it securely in place with prop.
3. Remove radiator cap.

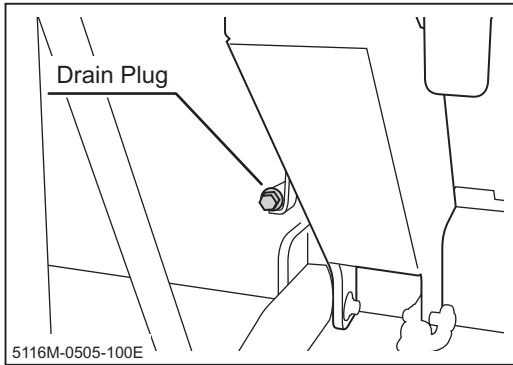

4. Remove drain plug to drain coolant.
5. Wash inside radiator with running water.
6. Replace drain plug.

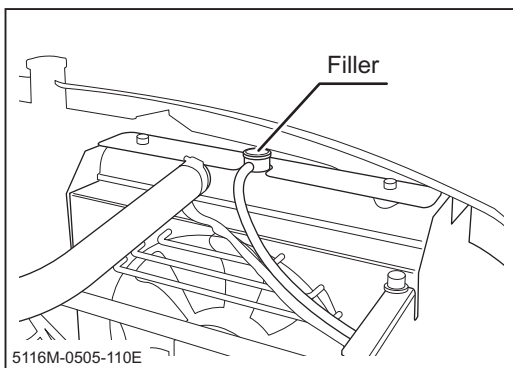

7. Fill coolant into radiator up to filler.

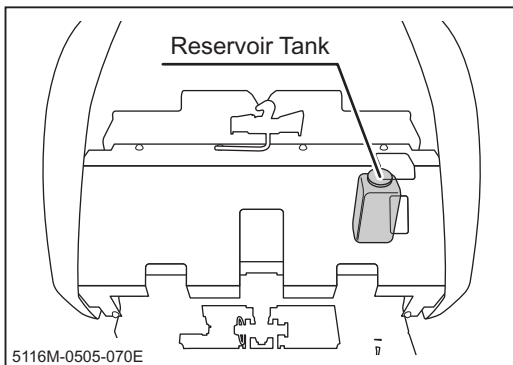

8. Change coolant in reservoir tank.
9. Run engine for 5 minutes to bleed air.
10. Allow engine to cool and open radiator filler cap and top up with coolant.
11. Replace radiator cap.
12. Close top cover.

Ambient Temperature	Antifreeze Mixture
-10 °C	30%
-15 °C	35%
-20 °C	40%
-25 °C	45%

\* The value for the ambient temperature is 5°C lower than the actual minimum temperature.

### Antifreeze Mixture (Reference)

When this machine is shipped from the factory, it is filled with a mixture of 40% antifreeze and 60% water. To prevent coolant from freezing, use a mixture of water and antifreeze determined by the minimum temperature in the operation area using the table on the left.

### NOTE

- Antifreeze to use: Long Life Coolant (LLC).
- Use pure water to make antifreeze mixture.

## Air Cleaner

**⚠ CAUTION!**

- Clean air cleaner element everyday. Dirty cleaner element causes difficult starting, reduces engine performance and shortens engine life.
- Clean air cleaner element twice a day when working in extremely dusty environment.
- Replace cleaner element if damaged.

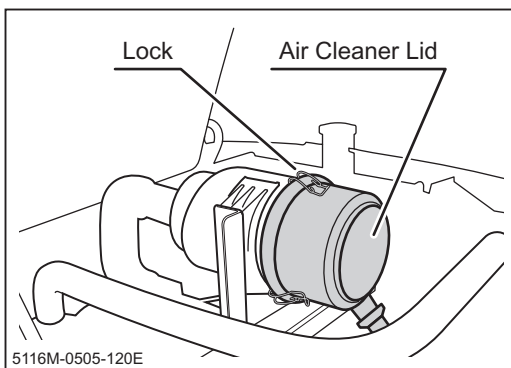

1. Open top cover and hold it securely in place with prop.
2. Undo locks to remove air cleaner lid.
3. Remove air cleaner elements.

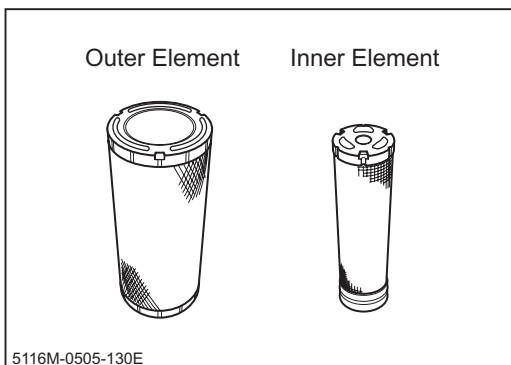

4. Tap element lightly to dust out. If necessary, blow compressed air from inside of element to blow off dust. If element is extremely dirty or damaged, replace with a new one.
5. Install air cleaner elements and replace air cleaner lid. Secure lid with locks.
6. Close top cover.

## Fan Belt

### ⚠ CAUTION!

- Adjust fan belt properly. Loose belt slips and reduces cooling airflow and electricity generated by alternator. Slippage also reduces belt life.

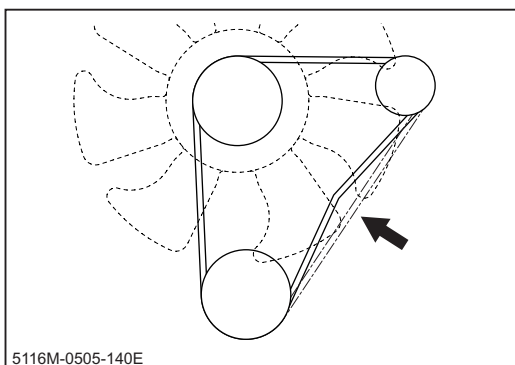

### Inspecting

1. Open top cover and hold it securely in place with prop.
2. Push in the middle of belt to check amount of bending. If it is not correct, adjust.

### NOTE

- Amount of bending: 7mm with 5kgf.

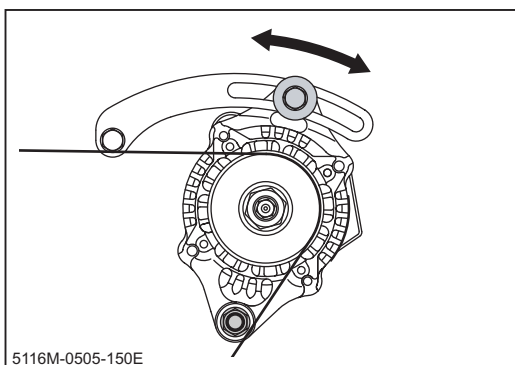

### Adjusting

1. Loosen bolt that fixes alternator.
2. Move alternator to adjust belt tension.

## Fuel System

### ⚠ WARNING!

- Stop engine when servicing fuel system.
- Keep fire and spark away when handling fuel.
- Do not spill fuel. If case fuel is spilt, wipe out immediately.

### ⚠ CAUTION!

- Dispose of drained fluid properly.

## Bleeding

When air enters into fuel system after it is completely run dry or fuel filter is replaced, it becomes impossible to start engine. If that happens, bleed fuel system as follows:

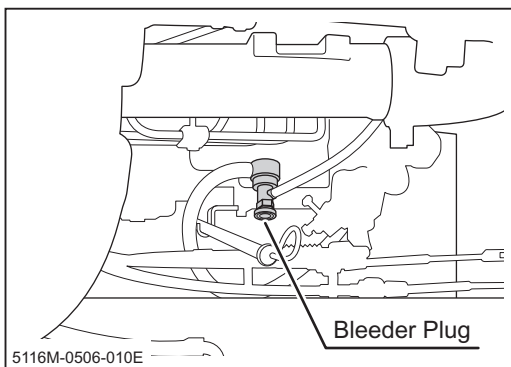

1. Fill fuel.
2. Open top cover and hold it securely in place with prop.
3. Loosen bleeder plug.
4. Turn main switch to [ | (ON)] to run fuel pump for 5 seconds.
5. Tighten bleeder plug.
6. Close top cover.

## Draining Water

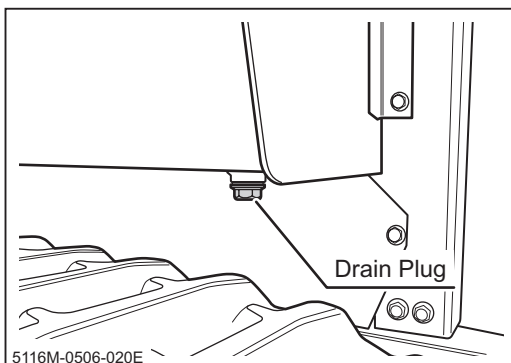

1. Remove left side cover.
2. Remove drain plug to drain water and sediment along with remaining fuel.
3. Replace drain plug.
4. Install left side cover.
5. Fill fuel and bleed fuel system.

## Fuel Filter Cartridge

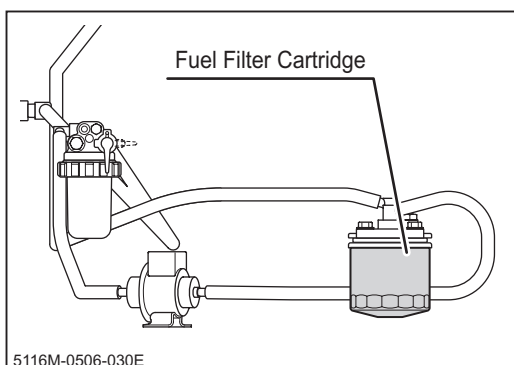

1. Remove controls cover.
2. Remove fuel filter cartridge with oil filter wrench.

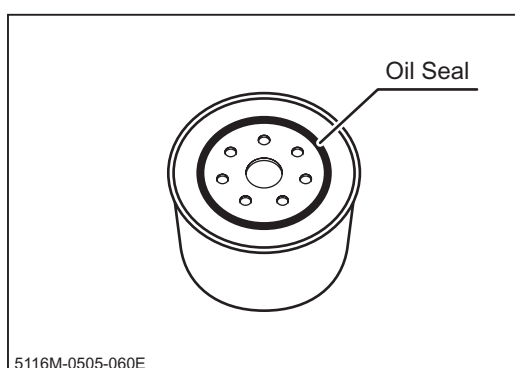

3. Prepare new filter cartridge. Coat its oil seal with fresh fuel.
4. Install cartridge and tighten it fully with hand.
5. Fill fuel and bleed fuel system.
6. Start engine and make sure there is no leak from filter.
7. Install controls cover.

## Hydraulic System

### ⚠ WARNING!

- Stop engine when servicing hydraulic system.
- Allow machine to cool off before servicing. Engine is very hot after operation and may pose a burn hazard.

### ⚠ CAUTION!

- Dispose of drained fluid properly.

## Hydraulic Fluid

### ⚠ CAUTION!

- Maintain sufficient amount of hydraulic fluid in hydraulic system. If there is not sufficient amount of fluid, air can enter into circuit, affecting its operation and reducing efficiency.

### NOTE

- To obtain correct reading, check fluid level before running engine. Fluid gets hot and expands after running engine.
- Replace suction filters when hydraulic fluid is changed.
- Always check oil level on a level surface.
- Fluid capacity and grade: Page 39.

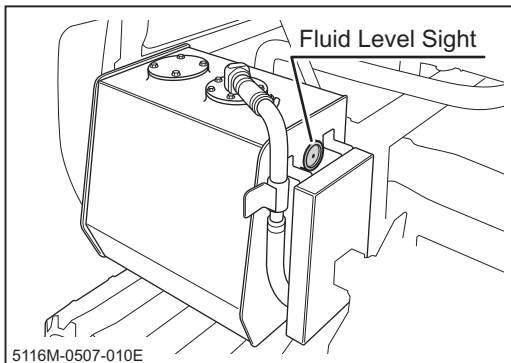

### Inspecting

1. Park machine on a level surface.
2. Remove right side cover.
3. Visually inspect fluid level and condition in fluid level sight on fluid tank.
4. If level is low, fill.
5. If fluid is dirty, change.
6. Install right side cover.

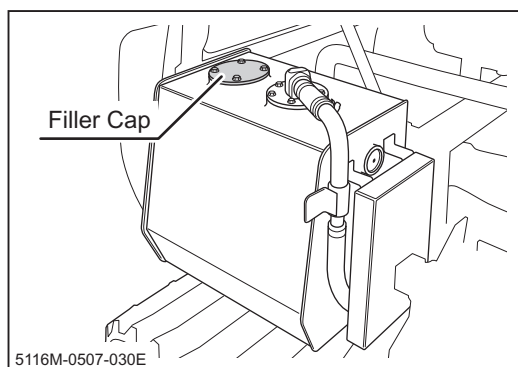
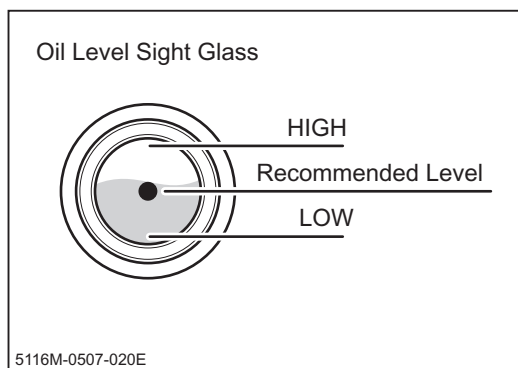

## Filling

1. Remove filler cap.
2. Fill specified fluid into filler.
3. Check fluid level.
4. Replace filler cap.

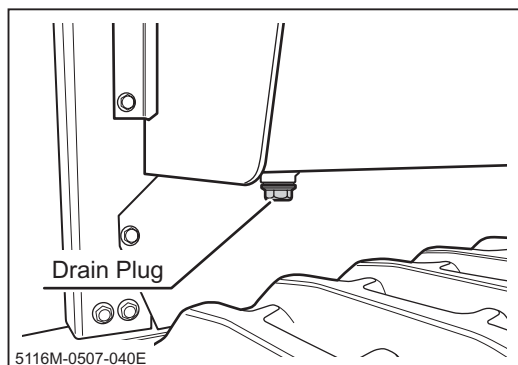

## Changing

1. Have an appropriate drain pan.
2. Remove right side cover.
3. Remove drain plug to drain fluid.
4. Replace drain plug.
5. Fill fluid.
6. Run engine to bleed air in hydraulic circuit.
7. Check fluid level.
8. Install right side cover.



## Suction Filter

### NOTE

- Replace suction filters when hydraulic fluid is changed.

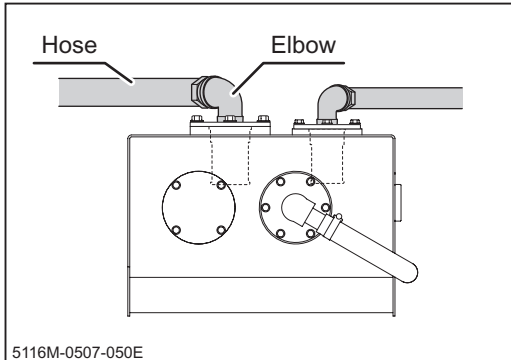

1. Drain fluid.
2. Loosen hose clamp to remove hose from elbow.
3. Remove elbow.

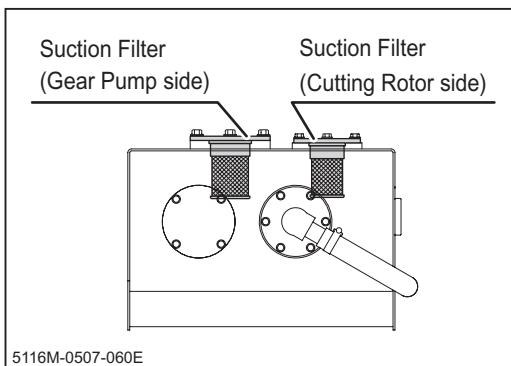

4. Undo mount bolts to remove suction filter from tank.
5. Install new suction filter.
6. Install elbow.

### NOTE

- Wrap seal tape around threaded part of elbow.

7. Install hose with hose clamp.
8. Fill fluid.

### NOTE

- Visually check that there is no leak from hose joints or elbows.

## Return Filter Element

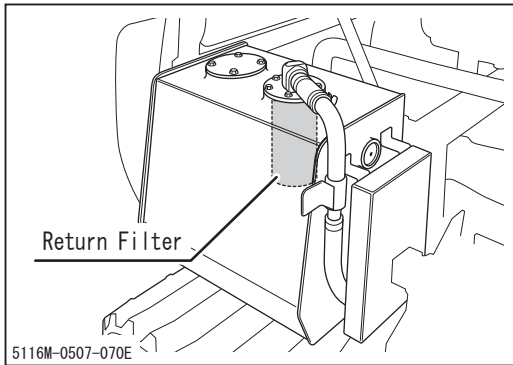

1. Loosen hose clamp to remove hose.
2. Undo mount bolts to remove return filter from tank.

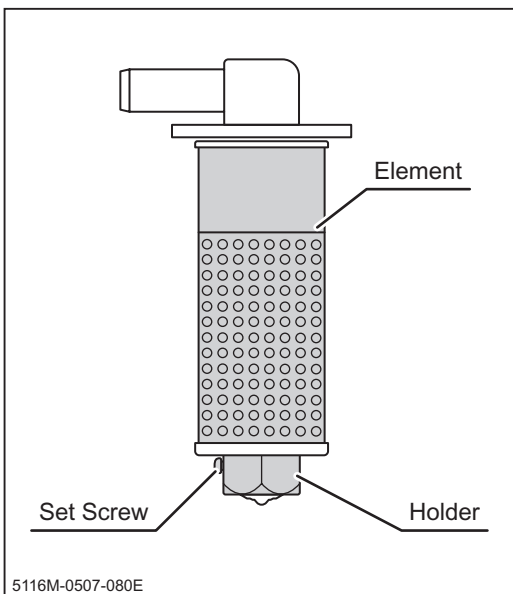

3. Loosen set screw and turn holder to remove.
4. Replace element with new one.
5. Replace holder.
6. Tighten set screw.

### NOTE

- Tightening Torque: 14.5kgf·cm.

7. Install return filter onto tank.
8. Install hoses.

### NOTE

- Make sure there is no leak from hose joints or elbows.

## Drive Train

### ⚠ WARNING!

- Stop engine when servicing drive train.

## Track

### ⚠ WARNING!

- When jacking up machine, hold machine with jack stands securely. Use jack stands with sufficient load rating.
- Projection hazard: track adjuster cylinder is highly pressurized. When loosening valve, loosen gradually, or valve can shoot off. Also avoid positioning your body directly against valve or put your head near it.
- Make certain to adjust track tension properly. Improperly tensioned tracks may wear or come off, resulting in property damage, serious injury or death.

### ⚠ CAUTION!

- Track stretches during its use-life. Inspect and adjust regularly.
- Track is heavy. Handle with care.

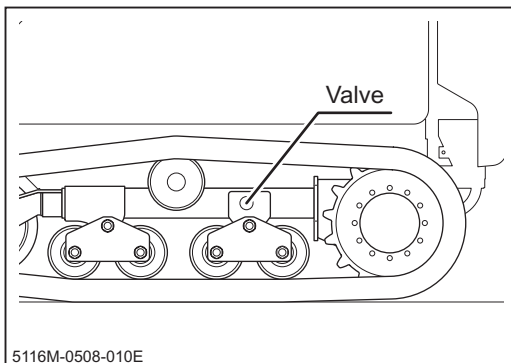

### Adjusting

1. Park machine on a level surface.
2. Lift one side of track by jacking up or hoisting machine. Make sure track is parallel to the ground from the side.
3. Undo 2 bolts to remove adjuster valve cover.
4. Attach grease gun to adjuster valve. Inject grease to tighten track.

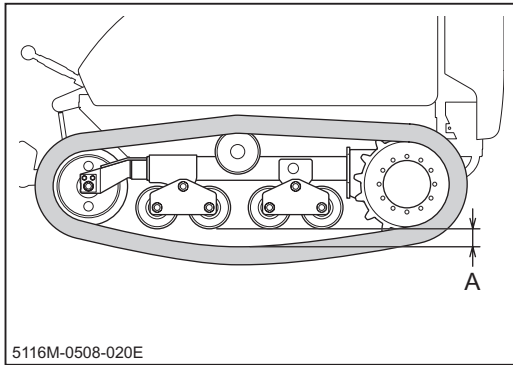

- Adjust track so that the gap between track and roller (A) is between 30mm and 40mm with roller swing horizontal.

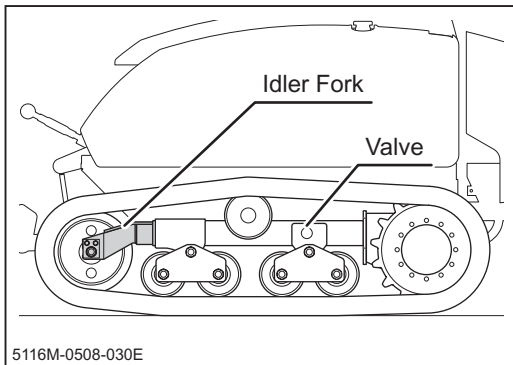

## Changing Track

Install track when it derails.

- Park machine on a level surface.
- Lift one side of track by jacking up or hoisting machine.
- Loosen adjuster valve a little to reduce pressure inside adjuster cylinder.
- When sufficiently depressurized, remove valve.
- Push idler fork in.
- First put track on the sprocket-side, then put it around idler.
- Install valve. Make sure not to jam o-ring. Tighten it securely.
- Adjust track tension.

## Drive Motor Lubricant

### ⚠ WARNING!

- Allow machine to cool off before servicing. Drive components are very hot after operation and may pose a burn hazard.

### ⚠ CAUTION!

- Dispose of drained fluid properly.

**NOTE**

- Fluid capacity and grade: Page 39.

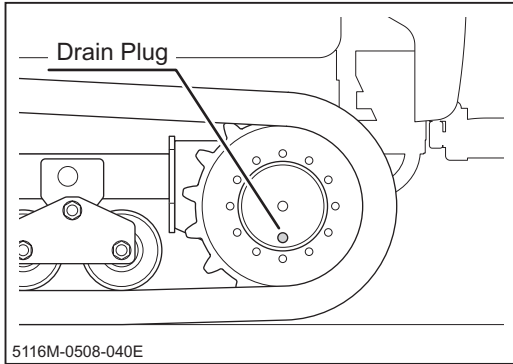

1. Park machine so that drain plug on drive motor is in the lowest position.
2. Have an appropriate drain pan.
3. Remove drain plug to drain lubricant.

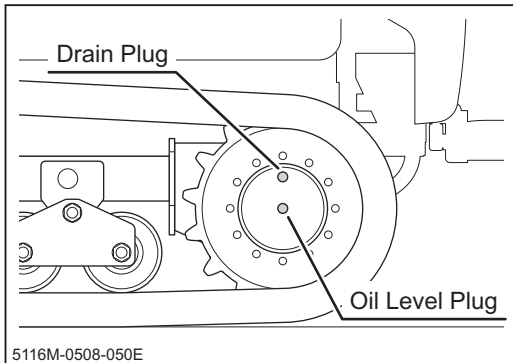

4. Move machine so that drain hole is placed above check plug.
5. Remove check plug.
6. Fill specified lubricant into drain hole until it flows out of check hole.
7. Replace drain and check plugs.

**Greasing****⚠ CAUTION!**

- Follow the maintenance schedule to grease up machine. Lack of greasing may result in rust, excessive wear or seizure.

**NOTE**

- When using a manual grease gun, pump 5-6 times. When the handle of the gun becomes heavy, stop pumping immediately.
- When using a pneumatic grease gun, pump it for a few seconds.
- Grease to use: Page 39

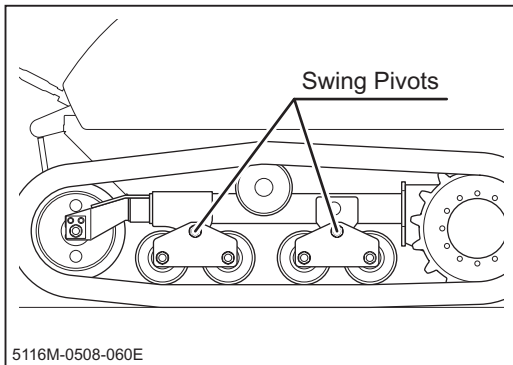

1. Grease roller swing pivots (4 places).

## Control Stick

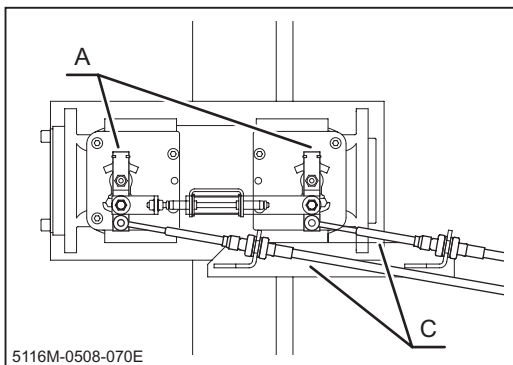

1. Adjust push-pull wires (C) so that links (B) is perpendicular when control levers (A) on HST pumps are in neutral.

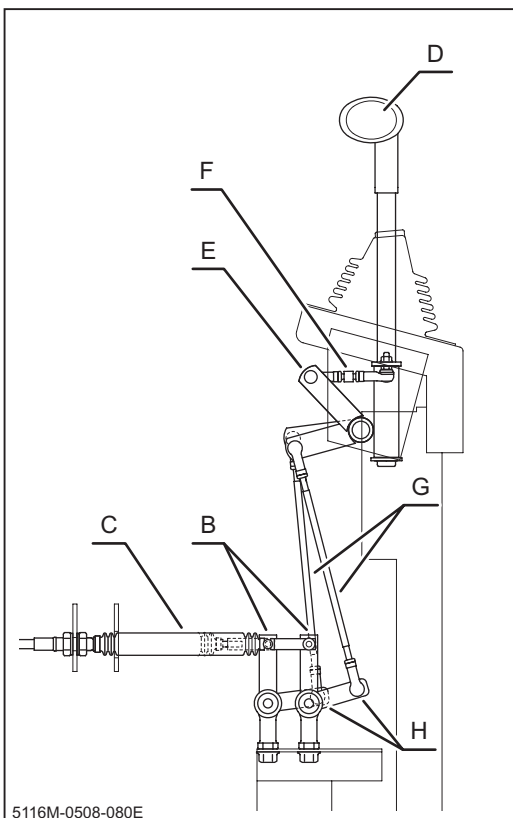

2. Adjust rods (F) so that links (E) on both sides are parallel when control stick (D) is vertical.

### NOTE

- Make sure there is no leak from hose joints or elbows.

3. Adjust rods (G) so that links (B) start to move at the same time when control stick (D) is tilted forward and backward.
4. Start engine and turn parking brake switch to [RUN] and observe if machine moves. If it does, stop engine and adjust again until it does not move.
5. Drive machine straight forward and backward and observe if machine travels straight. If it does not, move the location of link balls in slots (H). Fine-tune with rods (G).

## Electrical System

### **⚠ WARNING!**

- Always stop engine, turn main switch to [ ○ (OFF) ] and remove key when inspecting or servicing electrical system.
- Shock hazard: never work on electrical system with wet hand.

## Battery Fluid

### **⚠ WARNING!**

- Never use machine when battery fluid level is below [Lower Level]. It severely shortens battery life and can cause battery explosion.
- Battery fluid (diluted sulfuric acid) is corrosive and causes severe burns. Be extremely cautious when handling battery fluid. If battery fluid is spilled on clothes, immediately rinse with plenty of water. If spilled on skin or in an eye, immediately rinse with plenty of water and promptly consult a physician.
- Explosion hazard. Keep open flame or spark away from battery. Hydrogen gas generated during charging is extremely explosive.
- Shock hazard: never touch battery terminal. Electrocutation may result.
- Use wet cloth to clean battery. Dry cloth may generate static electricity, which may cause explosion.

### **⚠ CAUTION!**

- Never fill battery fluid beyond [Upper Level]. Battery fluid may spill and cause damage to machine or injury to person.

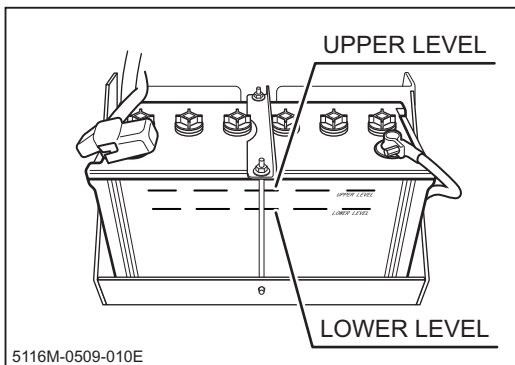

5116M-0509-010E

## Inspecting

1. Park the machine on a level surface.
2. Visually inspect that battery fluid level is between "Upper Level" and "Lower Level" lines.
3. If the fluid level is below "Lower Level," fill.

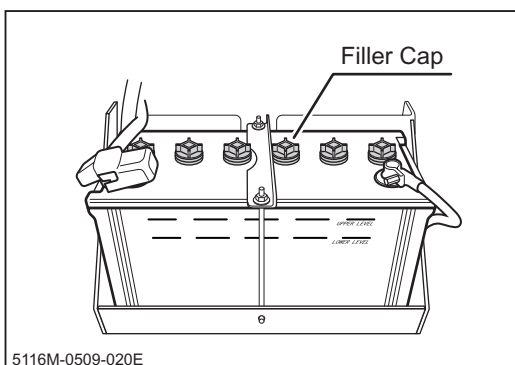

5116M-0509-020E

## Filling

1. Remove right side cover. (Page 44).
2. Remove filler caps.
3. Fill distilled water up to "Upper Limit."
4. Put filler plugs back in place.



## Charging Battery

### **⚠ WARNING!**

- Never charge battery when the fluid level is below [Lower Level]. Charging battery with insufficient fluid may shorten battery life or cause an explosion.
- Battery fluid (diluted sulfuric acid) is corrosive and causes severe burns. Be extremely cautious when handling battery fluid. If battery fluid is spilled on clothes, immediately rinse with plenty of water. If spilled on skin or in an eye, immediately rinse with plenty of water and promptly consult a physician.
- Explosion hazard. Keep open flame or spark away from battery. Hydrogen gas generated during charging is extremely explosive.
- Shock hazard: never touch battery terminal. Electrocuting may result.
- Always disconnect the negative (-) terminal first, and connect the positive (+) terminal first. Disconnecting or connecting in the opposite order may cause a short circuit.
- When installing the battery, make certain to connect the positive (+) and negative (-) terminals to their respective original positions. Avoid contact between terminals and other surrounding parts.

### **⚠ CAUTION!**

- Always remove battery from machine before charging. Failure to do so causes damage to electrical components and wiring.
- When using battery charger, follow instructions in its operator's manual.

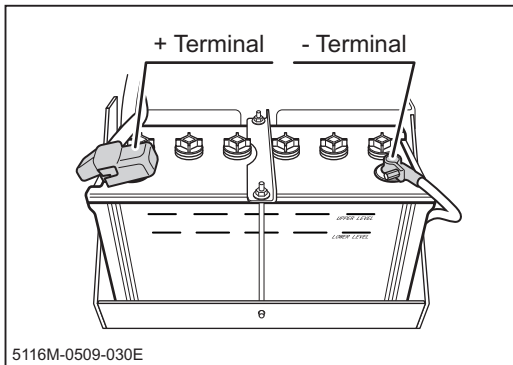

1. Park machine on a level surface.
2. Remove right side cover.
3. Remove negative (-) cable from terminal.
4. Remove positive (+) cable from terminal.
5. Remove battery from machine.

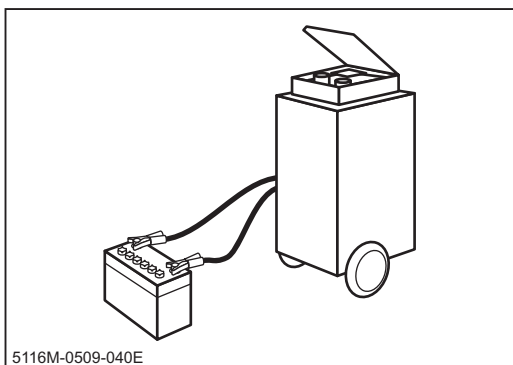

6. Follow instructions in battery charger operator's manual to charge battery.
7. When charge is complete, install battery to machine.
8. Install right side cover.

## Fuses

### ⚠ CAUTION!

- If a fuse blows, investigate the cause and repair it before replacing.
- Always replace a fuse with the one of the correct amperage.

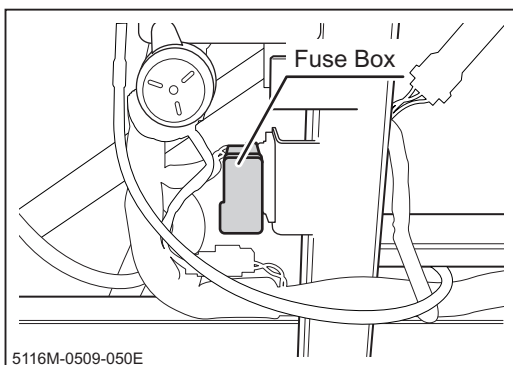

1. Remove controls cover.
2. Open fuse box and inspect fuses.
3. If fuse is blown, replace it with a new one of the correct amperage.
4. Close fuse box. Install controls cover.

### NOTE

- Spare fuses (10A, 15A) are provided in fuse box.

## Slow-Blow Fuses

### ⚠ CAUTION!

- If a slow-blow fuse blows, investigate the cause and repair it before replacing.
- Always replace a slow-blow fuse with the one of the correct amperage.

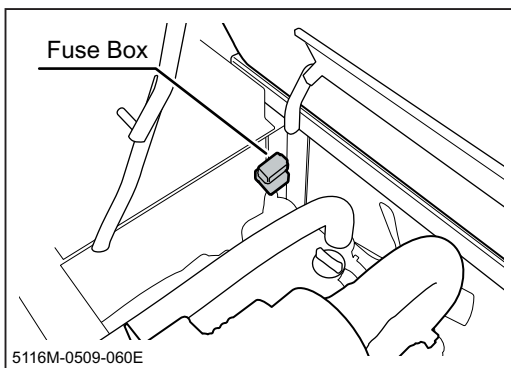

1. Open top cover and hold it securely in place with prop.
2. Open fuse box and inspect fuses.
3. If fuse is blown, replace it with a new one of the correct amperage.
4. Close top cover.

### NOTE

- A spare fuse is provided in fuse box.

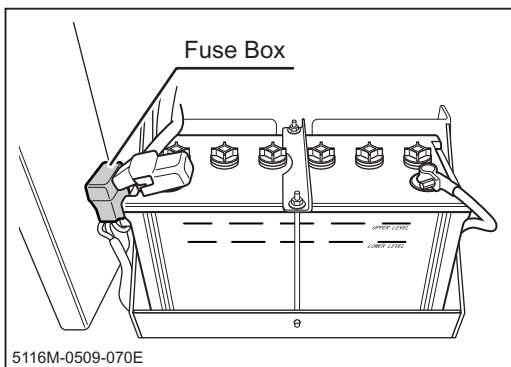

5. Remove right side cover.
6. Open fuse box and inspect fuses.
7. If fuse is blown, replace it with a new one of the correct amperage.
8. Install right side cover.

## Implement

### Attaching/Detaching Implement

#### **⚠ WARNING!**

- Park machine on a level surface when attaching or detaching implement.
- Do not go under implement.
- Always release residual pressure of hydraulic components when detaching implement, or oil under high pressure may leak and penetrate through skin and cause injury upon contact.
- Hydraulic fluid is very hot right after use. Allow hydraulic fluid to cool before detaching implement, or severe burns may result.

#### **⚠ CAUTION!**

- Never turn cutting on rotor switch when quick couplers are detached. Hydraulic components or plumbing can be damaged.

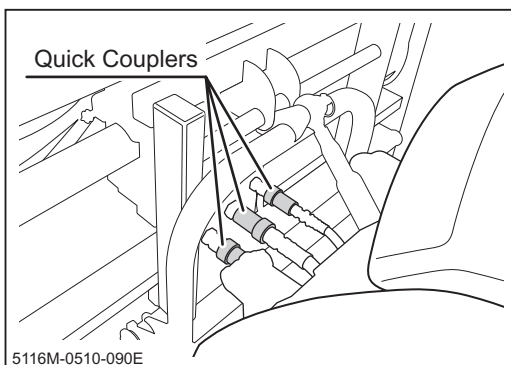

1. Park machine on a level surface.
2. Lower implement until it rests on the ground.
3. Detach quick couplers on hydraulic hoses.

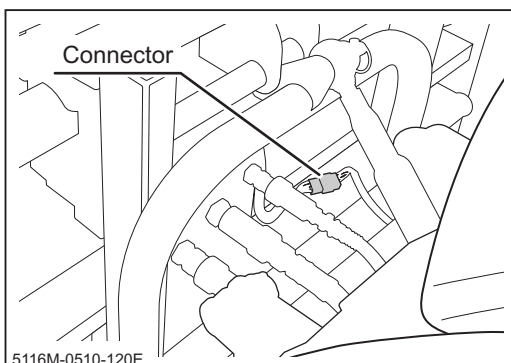

4. Detach connector on wiring harness.

# 5

# Maintenance

---

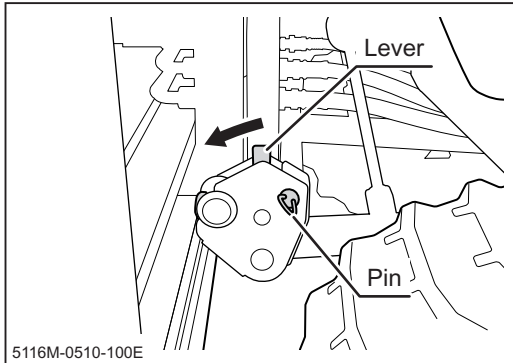

5. Remove link pins and pins. (2 places on both sides.)
6. Fold down lever to unlock.

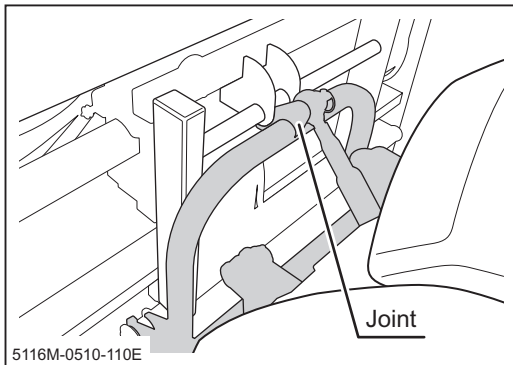

7. Lower link to unhook.
8. Drive backwards to remove implement.

---

## After Use Care

### **⚠ CAUTION!**

- Do not wash engine, control panel, electrical parts, or tank caps with air breather with running water; water may enter inside and cause rust or damage.
- Clean machine after use; leaving dirt or foreign objects may cause damage.
- Do not attempt to move machine when it becomes inoperable due to freezing.

## After Normal Use

1. Clean machine; wash off dirt, mud, and other foreign matter after use.
2. If machine is to be left outside, cover machine with protective, water-proof covering after machine is cooled off.

## After Cold Weather Use

1. Clean machine; wash off dirt, mud, and other foreign matter after use.
2. Park machine on a paved or firm, dry surface.
3. If machine is to be left outside, cover machine with protective, water-proof covering after it is cooled off.

## Storage

### **⚠ WARNING!**

- Fire hazard; do not store machine where there is a possibility of ignition.

### **⚠ CAUTION!**

- Do not wash engine or control panel with running water; water may enter inside and cause rust or damage.
- Clean machine before storage; leaving dirt or foreign objects may cause rust or damage.
- Do not store machine in a humid, dusty, or hot place.

1. Park machine.
2. Clean dirt off of machine.
3. Check machine according to **Maintenance Schedule** chart (Page 34) and service as necessary.
4. Clean steel parts of machine with oil-soaked rag. Grease greasing points.
5. Change engine oil.
6. Completely drain coolant from engine cooling system.
7. Clean air cleaner.
8. Drain fuel from fuel tank.
9. Remove battery from machine. Service battery.
10. Cover machine with protective, water-proof covering after machine is cooled off.

### **NOTE**

---

- Battery discharges even when it is not in use. A battery may hold charge for a few months, but it is a good practice to charge battery before it goes flat; it will extend the battery life.
- Refer to the Operation Manual for the engine, for detailed instructions on preparing engine for storage.

## Troubleshooting

- If any malfunction or abnormal condition is found, immediately stop using the machine and take an appropriate measure according to the Troubleshooting chart below. If the malfunction or abnormal condition is not listed in the chart, or the suggested measure does not solve the problem, consult with your CANYCOM representative.
- Some corrective measures listed below require special knowledge and/or equipment. Please contact your CANYCOM representative in such a case.

Area	Malfunction	Possible Cause	Corrective Measure	Ref.	
Engine	Engine does not start, or is difficult to start	Out of fuel.	→Fill fuel.	Page 16	
		Air in fuel line.	→Bleed fuel line.	Page 52	
		Water in fuel system	→Drain water.	Page 52	
		Insufficient battery capacity	→Add battery fluid. →Charge battery. →Replace battery.	Page 62	
		Insufficient or wrong oil.	→Fill or change oil.	Page 45	
		Other (other than the above).	→Follow the instructions in "Starting" to restart. If problem persists, please contact your CANYCOM representative.	Page 18	
	Engine stalls.		Out of fuel.	→Fill fuel.	Page 16
			Air in fuel line.	→Bleed fuel line.	Page 52
			Cold engine.	→Warm up engine.	
			Other (other than the above).	→Please contact your CANYCOM representative.	
	Engine stops abruptly.		Out of fuel	→Fill fuel.	Page 16
			Other (other than the above).	→Please contact your CANYCOM representative.	
	Idling is not stable.		Insufficient intake air (clogged air cleaner).	→Clean or replace the air cleaner.	Page 50
			Other (other than the above).	→Please contact your CANYCOM representative.	



Area	Malfunction	Possible Cause	Corrective Measure	Ref.
Engine	Engine does not stop	Electrical malfunction	→Please contact your CANYCOM representative.	
		Other (other than the above).	→Please contact your CANYCOM representative.	
	Poor power or acceleration	Bad fuel	→Change fuel.	
		Wrong oil (wrong viscosity)	→Change for correct oil.	Page 45
		Insufficient intake air (clogged air cleaner).	→Clean or replace the air cleaner.	Page 50
		Other (other than the above).	→Please contact your CANYCOM representative.	
	Irregular noise or vibration from or around the engine	Loose engine mount bolt(s).	→Tighten.	
		Other (other than the above).	→Please contact your CANYCOM representative.	
	Excessive oil consumption		→Please contact your CANYCOM representative.	
	Engine overheats	Radiator or cooling fan is clogged or blocked.	→Clean.	
		Hydraulic cooling fan is in a wrong mode.	→Follow the instructions in "Hydraulic Cooling Fan" to select an appropriate mode for the condition.	Page 31
		Hydraulic cooling fan is faulty.	→Please contact your CANYCOM representative.	
		Insufficient amount of engine oil.	→Fill oil.	Page 45
		Insufficient amount of coolant.	→Fill coolant.	Page 47
		Other (other than the above).	→Please contact your CANYCOM representative.	

Area	Malfunction	Possible Cause	Corrective Measure	Ref.
Engine	Excessive fuel consumption	Clogged air cleaner.	→Clean or replace the air cleaner.	Page 50
		Other (other than the above).	→Please contact your CANYCOM representative.	
	Black smoke comes out of exhaust	Clogged air cleaner.	→Clean or replace the air cleaner.	Page 50
		Other (other than the above).	→Please contact your CANYCOM representative.	
	White or blue smoke comes out of exhaust	Engine oil level is too high.	→Adjust oil level.	Page 45
		Wrong oil (wrong viscosity)	→Change for correct oil.	Page 45
		Other (other than the above).	→Please contact your CANYCOM representative.	
	Accelerator lever is catching	Faulty wire, rod or linkage.	→Please contact your CANYCOM representative.	
		Other (other than the above).	→Please contact your CANYCOM representative.	
	Drive Train	Machine does not move when control stick is operated.	Faulty hydraulic system.	→Refer to "Hydraulic Systems."
Other (other than the above).			→Follow the instructions in "Driving" to drive the machine. If problem persists, please contact your CANYCOM representative.	Page 22
Machine does not turn properly.		Faulty hydraulic system.	→Refer to "Hydraulic Systems."	Page 54
		Other (other than the above).	→Please contact your CANYCOM representative.	

# 6

# Troubleshooting

Area	Malfunction	Possible Cause	Corrective Measure	Ref.
Drive Train	Machine does not run straight	Tracks are not properly adjusted.	→Adjust.	Page 58
		Control stick is not properly adjusted.	→Adjust.	Page 61
		Other (other than the above).	→Please contact your CANYCOM representative.	
	Machine vibrates abnormally, or is not stable.	Track is derailed.	→Reinstall and adjust track.	Page 58
		Roller, sprocket, or idler is loose.	→Tighten the loose fastener.	
		Other (other than the above).	→Please contact your CANYCOM representative.	
Brake	Parking brake does not work well.	Faulty hydraulic system.	→Refer to "Hydraulic Systems."	Page 54
		Other (other than the above).	→Please contact your CANYCOM representative.	
Hydraulic System	Hydraulic equipment (hydraulic motor, cylinder) does not work properly or does not work at all.	Insufficient hydraulic fluid.	→Fill or change.	Page 54
		Clogged hydraulic oil filter	→Change.	Page 57
		Other (other than the above).	→Please contact your CANYCOM representative.	
	Cylinder contracts.	Foreign object caught in pilot check valve.	→Please contact your CANYCOM representative.	
		Faulty electromagnetic valve.	→Please contact your CANYCOM representative.	
		Other (other than the above).	→Please contact your CANYCOM representative.	

Area	Malfunction	Possible Cause	Corrective Measure	Ref.
Implement Drive	Implement does not run.	Faulty hydraulic system.	→Refer to "Hydraulic Systems."	Page 54
		Other (other than the above).	→Follow the instructions in "Working" to operate the machine. If problem persists, please contact your CANYCOM representative.	Page 26
	Implement vibrates excessively when it is run.	Foreign object is tangled.	→Untangle.	
		Other (other than the above).	→Please contact your CANYCOM representative.	
Safety Devices	Warning lamp does not light.	Blown fuse.	→Replace.	
		Blown bulb.	→Replace.	
		Other (other than the above).	→Please contact your CANYCOM representative.	
	Oil lamp stays on after engine starts.	Insufficient engine oil.	→Fill.	Page 45
		Other (other than the above).	→Please contact your CANYCOM representative.	
	Coolant Temperature lamp stays on after engine starts.	Engine overheats.	→Refer to "Engine."	Page 45
		Other (other than the above).	→Please contact your CANYCOM representative.	
	Charge lamp stays on after engine starts.	Blown fuse.	→Replace.	
		Other (other than the above).	→Please contact your CANYCOM representative.	
	Horn does not work.	Blown fuse.	→Replace.	
Other (other than the above).		→Please contact your CANYCOM representative.		

## Hauling

### Loading and Unloading

#### **⚠️ WARNING!**

- Park transporter (truck) on a level ground. Always use chocks to secure wheels.
- Do not allow bystanders to come close to machine or transporter when loading or unloading machine.
- Use only the loading ramps with sufficient strength (to withstand the combined weight of machine and operator), width (more than 1.2 times the width of track), and length (more than 4 times the height of loading deck of transporter), and have anti-slip ramp surfaces.
- Secure hooks of loading ramps firmly and flush with loading deck.
- Move slowly forward when loading onto, and move slowly backward when unloading off of transporter. Pay special care when going over the joint between loading deck and ramps; machine may tip.
- Do not turn on loading ramps. Machine may fall.
- Tie down machine securely. Make sure machine does not move around on loading deck.

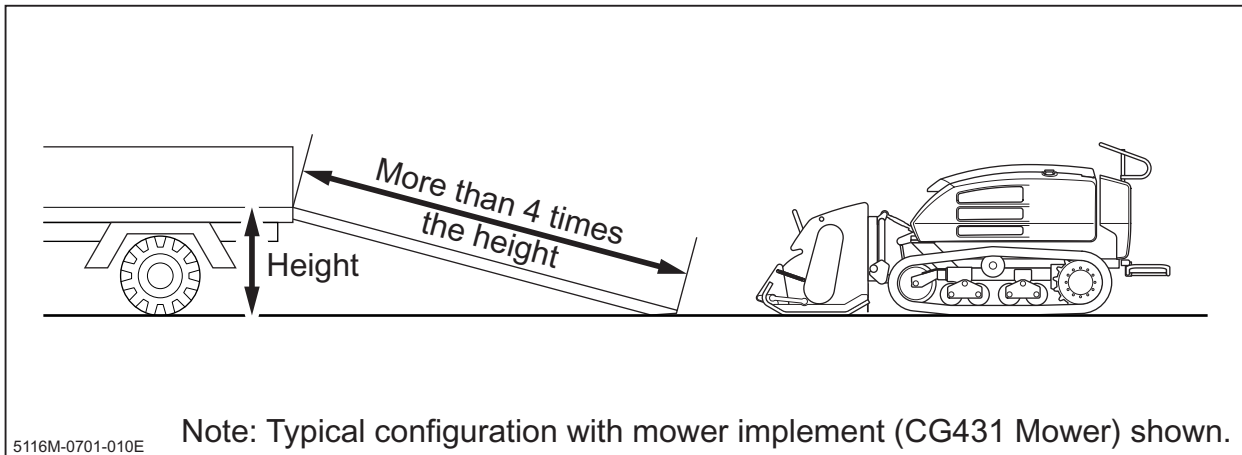

## Loading to Transporter

1. Park transporter. Secure wheels with chocks.
2. Place loading ramps. Secure hooks of ramps firmly and flush with loading deck.
3. Lift up implement.
4. Set auxiliary transmission switch to [  (slow)]. Raise cutting rotor so that it does not hit ramp or loading deck of transporter. Drive machine slowly forward onto loading deck.
5. Park machine according to the instructions in "**Stopping**" (Page 24). Tie machine down with rope or tie-down belts and secure it onto loading deck of transporter securely.

## Hoisting

### ⚠ WARNING!

- Hoisting may require appropriate training or licence. Consult with your local authority.
- Use hoisting sling of sufficient strength. Always use slings of the same length when more than one is used.
- Pay attention to the balance and the location of the center of gravity of machine.

### ⚠ CAUTION!

- Do not use wire rope when hoisting. It will damage tracks.

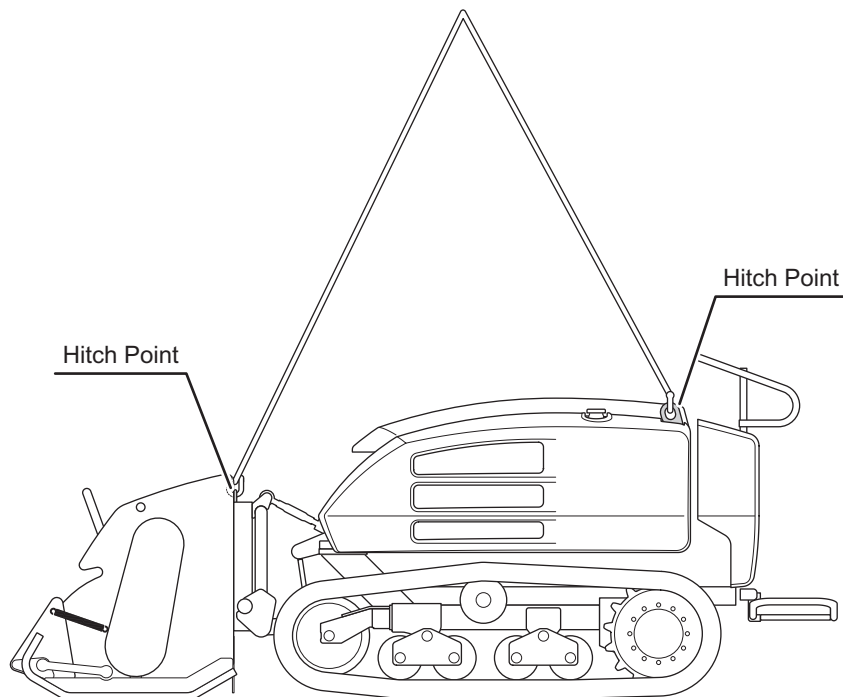

5116M-0702-010E

1. Attach hoisting slings to hitch points of machine. Hoist the center of slings.

### NOISE LEVEL

Model	Engine		LwA
	Type	Speed rpm	
CG431	Kubota V2203	2,800 rpm	98 dB (A)

NOISE LEVEL evaluated based on factory standard.

### VIBRATION

Model	Engine Rated revolution		
		Steering lever	Seat
CG431	2,800 rpm	3.0 m/s <sup>2</sup>	3.0 m/s <sup>2</sup>

VIBRATION evaluated based on factory standard.



Front Flail Brushcutter

# CG431 MOWER

## Operator's Manual

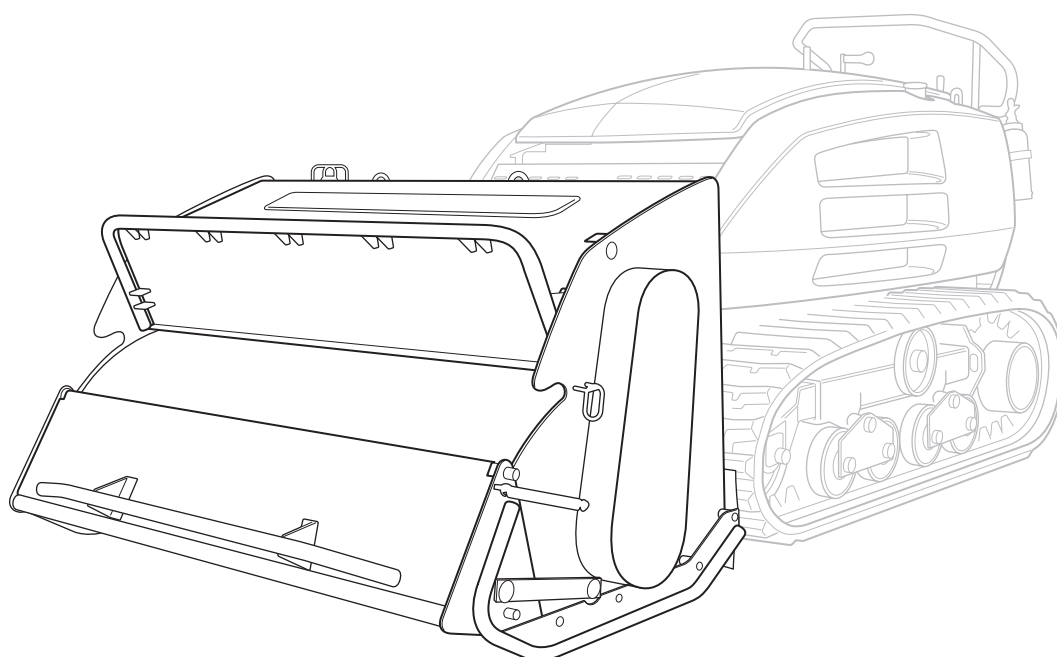

### **⚠ WARNING!**

Read this manual completely before operating or maintaining this machine.  
Failure to follow safety precautions could result in serious injury or death.  
Keep this manual for future reference by you and by all those who operate  
and maintain this machine.

5116 5104 001

**Original Instructions**  
(in English)

**CHIKUSUI CANYCOM, INC.**

90-1 Fukumasu, Yoshii-machi,

Ukiha-shi, Fukuoka, Japan 839-1396

Tel.+81-(0)943-75-2195 Fax.+81-(0)943-75-4396

---

# CHIKUSUI CANYCOM, INC.

<http://www.canycom.co.jp/>

---

- Sales Headquarters TEL +81-(0)943-75-2195 FAX +81-(0)943-75-4396
- Foreign Trade Center TEL +81-(0)3-3552-6277 FAX +81-(0)3-3552-6288

Authorized Dealer

---

## Notice to Users and Maintenance Personnel

Thank you for purchasing this machine.

This manual provides information needed for safe and effective use and maintenance of this machine to those who operate or maintain the machine. Make sure to read and understand the manual thoroughly before operating or servicing the machine. Also make sure to read the separate operator's manual for engine.

### **WARNING!**

- **This machine can be very dangerous if the safety precautions in this manual and on the labels attached to this machine are not followed. Read and understand this manual and the safety labels on the machine thoroughly before using or servicing the machine. Always follow the instructions and safety precautions, or serious injury or death could result.**
- **This machine is intended to be used in combination with the CG431 tractor. Use with any other machine may pose hazard.**
- **This machine should only be used for its intended purpose: brushcutting. Any other use could be dangerous.**
- **This machine may not be operated on public road or what is considered to be public road. It is the sole responsibility of the operator to consult the local regulations.**
- **Do not modify this machine, or do not operate this machine with safety covers removed or open. A serious accident could result.**

### **CAUTION!**

- **Store this manual in a safe, accessible place for easy reference.**
-

---



## Notice to Owner

### CAUTION!

- Be sure that everyone who uses this machine, including those who rent or lease this machine, receives a copy of this Operator's Manual and understands the importance of reading and following the information in this manual.

## Warning Terms Used in this Manual

In this manual, the following four warning terms are used to signal the four levels of hazard (or seriousness of possible accidents). Read and understand what they mean and always follow the instructions in this manual.

Warning Term	Definition
 <b>DANGER!</b>	Indicates an imminently hazardous situation which will result in death or serious injury if the user does not follow the procedures or the instructions.
 <b>WARNING!</b>	Indicates a potentially hazardous situation which could result in death or serious injury if the user does not follow the procedures or the instructions.
 <b>CAUTION!</b>	Indicates a potentially hazardous situation which could result in minor to moderate injury or damage to the machine if the user does not follow the procedures or the instructions.
<u>NOTE</u>	Indicates important information which needs particular attention.

---

---

# Warranty and After-Sales Service

## Warranty

CHIKUSUI CANYCOM, INC. guarantees this product, based on the terms of warranty. A copy of this warranty is reproduced in the back of this manual.

## After-Sales Service

Consult your local CANYCOM dealer or our company's sales department regarding service orders or any questions or problems that may arise when using this machine. Please make sure to have the product name, serial number, and the make and type of engine handy at the time of contact. The model and serial numbers can be found on the model label as shown below, and the make and type of the engine can be found in Chapter 3 "**Specifications**" of this manual (Page 7).

### Location of Model Label

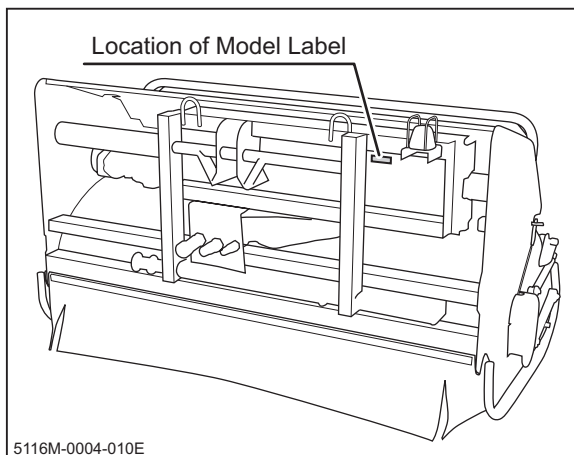

### Model Label



## Availability of Spare Parts

The replacement or repair parts for this product shall remain available for seven years after the production of this type of machine is discontinued.

---

---

# Contents

<b>1. Safety</b>	<b>1</b>
<b>Safety Labels</b> .....	<b>1</b>
<b>Safety Precautions</b> .....	<b>2</b>
Training .....	2
Preparation .....	3
Operation .....	3
Servicing .....	5
<b>2. Controls and Components</b>	<b>6</b>
<b>Name and Function of Controls</b> .....	<b>6</b>
<b>3. Specifications</b>	<b>7</b>
<b>Product Specifications</b> .....	<b>7</b>
<b>4. Operation</b>	<b>8</b>
<b>Preparation</b> .....	<b>8</b>
Pre-start up Inspection .....	8
<b>Working</b> .....	<b>8</b>
Operating Implement .....	9
Changing PTO Speed (Variable PTO Speed Model Only) .....	11
Translating Implement .....	12
<b>5. Maintenance</b>	<b>13</b>
<b>Maintenance Schedule</b> .....	<b>13</b>
<b>List of Fluids and Lubricants</b> .....	<b>15</b>
<b>Grease Points</b> .....	<b>15</b>
<b>List of Consumables and Spares</b> .....	<b>16</b>
<b>Body Panels</b> .....	<b>17</b>
Opening Rotor Shield .....	17
Removing Rotor Belt Cover .....	17
Removing Upper Shield .....	18

---

---

<b>Cutting System</b> .....	<b>19</b>
Flail .....	19
Cutting Rotor Drive Belt .....	21
Greasing .....	22
Attaching/Detaching Implement .....	24

<b>After Use Care</b> .....	<b>26</b>
After Normal Use .....	26
After Cold Weather Use .....	26

<b>Storage</b> .....	<b>27</b>
----------------------	-----------

## **6. Troubleshooting** **28**

Troubleshooting .....	28
-----------------------	----

## **7. Transporting** **29**

Hoisting .....	29
----------------	----

## **Appendix**

- Operator's Manual for Engine

\* Be sure to read and understand it together with this manual .

---

## Safety Labels

Safety labels shown on the next page are attached to the machine. See the illustration below for the location and the content of each label on the machine.

- **Locate all warning labels attached to this machine. Read and follow the instructions and precautions in them. Failure to do so could result in serious injury or death to the operator or bystanders.**
- **Keep labels clean and legible. Do not use solvents or gasoline to clean labels.**
- **Replace these labels immediately if they have been removed, have fallen off or become illegible. Use part number written on the label or shown in this manual to order a replacement label from your CANYCOM representative.**

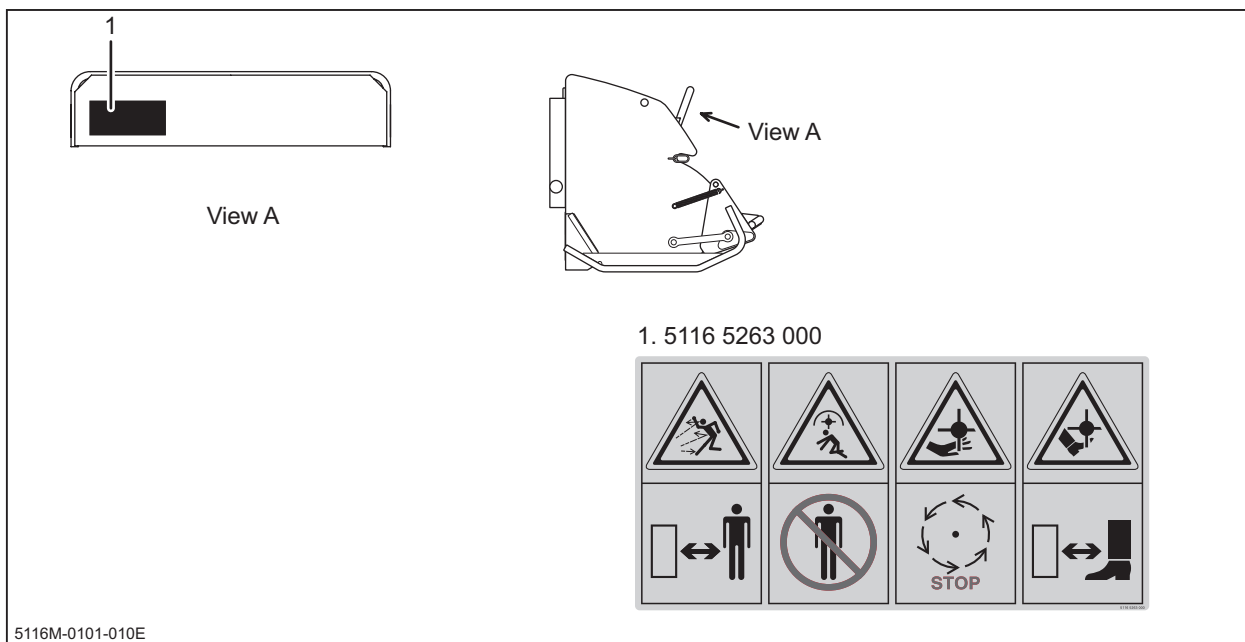



## Safety Precautions

This section contains safety precautions to follow when operating and maintaining the machine. Read and understand the precautions in this section as well as throughout this manual and follow them when operating or maintaining machine. Failure to follow safety precautions could result in property damage, serious injury or death to the operator or bystanders.

### Training

All operators and mechanics should receive practical instructions from their employer or renter. Such instructions should cover the following issues:

- **It is essential to familiarize yourself with the controls, safety labels and proper use of the machine.**
- **Never allow people unfamiliar with these instructions to operate or service the machine. Do not let anyone under 18 years of age to operate this machine. Local regulations may restrict the minimum age for operating this type of machine. Consult your local authority.**
- **Operator is responsible for the accidents or hazards caused to other people or to their property.**
- **This machine is intended to be used in combination with the CG431 tractor. Use with any other machine may pose hazard.**
- **Always keep in mind that attention and concentration is required when working with ride-on machines.**
- **Loss of control on a slope cannot be regained by the application of the brake. Main reasons for the loss of control are:**
  - **insufficient grip of tracks.**
  - **excessive speed.**
  - **misjudging of ground conditions, especially slopes.**
  - **excessive load.**
  - **incorrect distribution of load.**

## Preparation

- **Always wear protective footwear, long trousers, hardhat, safety glasses and ear protection when operating or servicing the machine. Proper clothing will minimize the chance of injury. Do not operate the machine if you have long hair, loose clothing, or jewelry; all of which may get tangled in the moving parts. Do not operate the machine barefoot or with open sandals.**
- **Prepare beforehand the working rules and procedures such as signaling and traffic control for the work place. Following such rules will reduce the risk of accidents.**
- **Never handle fuel, lubricants or other flammable materials, service engine, or recharge battery in the presence of fire or spark.**
- **Perform daily pre-startup inspection (see Preparation, page 16) before starting the machine. Repair or replace damaged parts before starting the machine. Clean the machine of cut grass or such refuse to avoid fire.**

## Operation

This mower is intended for brushcutting. It is intended to be used in combination with the CG431 tractor. Use only the CG431 tractor or any other tractors that are certified specifically for this mower. Use with any other tractor may adversely affect the performance or stability of the machine and can cause damage or accident.

The stability of the machine is affected by the speed, rate of steering, terrain and load. Always pay close attention to these factors or a loss of control or overturn could occur, resulting in property damage, serious injury or death.

### General Driving

- **Do not operate the machine under the influence of alcohol or drugs. Do not operate the machine when you are tired, ill, or not feeling well.**
- **Always check for obstacles before operating on new terrain.**
- **Before starting the engine and the moving machine, scan around your surroundings and make sure all persons and other vehicles are a safe distance away from the machine. Sound the horn to warn bystanders.**

- To reduce the risk of overturning, pay special attention when encountering an obstacle or a slope, or when braking on a slope or during a turn. See **Driving on a Slope** on the next page.
- Never attempt to drive over large obstacles such as rocks or fallen trees.
- Always travel slowly and use extra caution when operating on unfamiliar terrain. Be alert when traveling on changing terrain.
- Never operate on terrain that you are not comfortable with. Avoid terrain that is so rough, slippery or loose that you feel like you could overturn.
- Do not operate the machine near the edge of a cliff or a ditch, an overhang or a slide area. Pay special caution after rain or earthquake.
- Do not make sudden maneuvers. A sudden start, stop, or turn can make the machine lose control and could cause an overturn. Be especially cautious when traveling on soft or wet ground.
- Drive at a safe speed, taking into account the surface gradient, surface conditions and load.
- Use an observer to help direct the machine when the visibility is poor, terrain is rugged or hilly, or maneuvering room is limited. The observer should be able to see the machine and its immediate surroundings, and should give pre-arranged signals to direct the operator.

## Cutting

When conducting cutting operation, take the following precautions.

- Always follow the proper procedures for cutting as described in this manual.
- Shut off the work site. Post signs to inform that cutting operation is underway. Close off the site with rope if necessary to keep people, especially children, off the work site.
- Pay attention to the surrounding area. Running cutting rotor or implement throws stones, rocks and debris. This can cause property damage, injury, or death.

- Drive forward when cutting. This best prevents the cutting rotor or implement from throwing stones, rocks, or debris.
- Pay attention to obstacles. This includes overhead obstacles such as branches of a tree.

## Servicing

- Do not service the machine when the engine is running. If it is absolutely necessary to run the engine while servicing, pay attention to the moving parts; keep hands, feet, clothing and any part of your body away from any moving part, especially cooling fan and belts at the side of the engine.
- Do not operate the engine in a confined space where dangerous carbon monoxide fumes can accumulate.
- Make sure all hydraulic line connectors are tight and all hydraulic hoses and lines are in good condition and leak-free before applying hydraulic pressure to the system.
- Keep your body and hands away from pinhole leaks or nozzles that eject hydraulic fluid under high pressure. Use paper or cardboard, not your hands, to search for leaks. Hydraulic fluid escaping under pressure can have sufficient force to penetrate the skin and cause serious injury.

## Name and Function of Controls

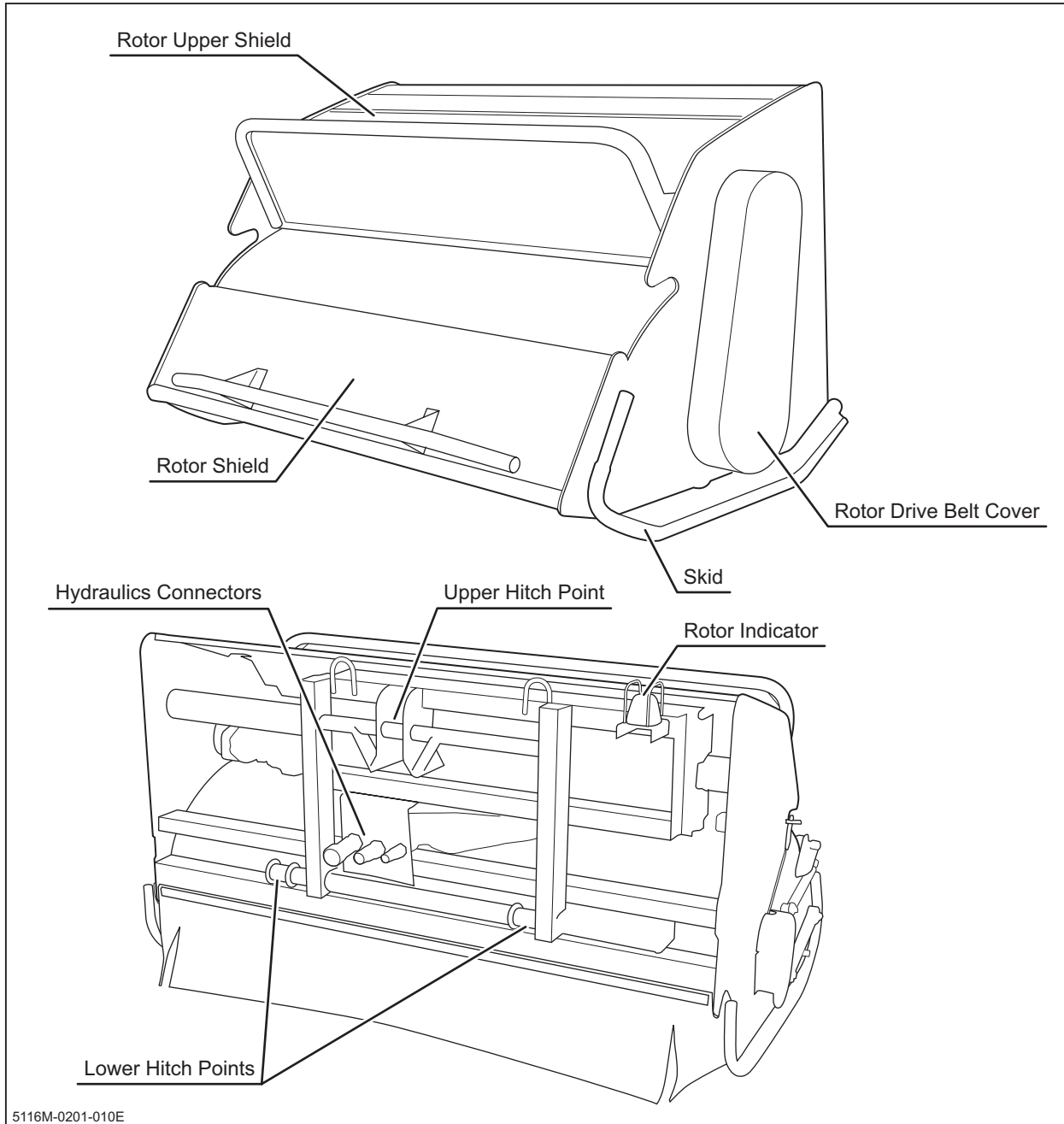

5116M-0201-010E

## Product Specifications

**⚠ CAUTION!**

- Understand the specifications of this product thoroughly before use.

Model and Type		CG431 Mower	
	Machine Mass	kg	410
Dimensions	Overall Length	mm	963
	Overall Width	mm	1700
	Overall Height	mm	972
Cutting System	Cutting System		Flail
	Cutting Width	mm	1545
	Number of Flails	Pairs	80
	Rotor Drive		HST
	Direction of Rotation		Same as / Opposit of Travelling
	Rotor Translation	mm	500 (to the right)
	Cutting Height	mm	0 - 320
	Rotor Outer Diameter	mm	410

## Preparation

### Pre-start up Inspection

Always perform an inspection before use.

Refer to **Maintenance Schedule** (page 13) for the inspection schedule and procedure.

## Working

### **DANGER!**

- Never place any part of body under implement when implement is running. See implement's manual for safe use.

### **WARNING!**

- Always tie string on safety switch to operator's body so that machine stops when operator falls off machine.
- Do not allow bystanders to come near machine when working.
- Running implement can throw stones or debris and cause injuries and damages to nearby people, animals, crops, buildings, automobiles, etc. Pay attention to the safety of surroundings and plan ahead when working.
- Never attempt to work with implement's shield open (if applicable).
- When working, drive forward. Machine is intended to perform the intended job while moving forward, and this best prevents stones and debris from being thrown.
- Turn implement switch to [ON] only when working. Keep it in [OFF] position all the other times.
- Never attempt to work brush on or near the edge of a ditch or bank. Shoulder of a ditch or bank may collapse. Pay extra care after heavy rain or earthquake.

## ⚠ WARNING!

- Inspect the work site beforehand; inspect terrain and locate holes, drops, or obstacles. Also inspect overhead obstacles such as branches of a tree. Pay special attention when working near these areas.

## ⚠ CAUTION!

- Do not use this machine on an incline steeper than 30 degrees.
- Always use [🐢 (Slow)] mode when working.
- Do not turn on an incline, or machine can tip over.
- Do not work on a slippery surface.
- When working in a dusty area, clean air cleaner element twice a day. Dirty air cleaner element results in poor starting, poor performance, or short life.
- When a flail knife is broken, replace it with new one. A broken flail causes excessive vibration, which damages machine.
- When something is tangled to implement, stop engine immediately and remove the tangled object. Such object causes excessive vibration or load, which damages machine.

## Operating Implement

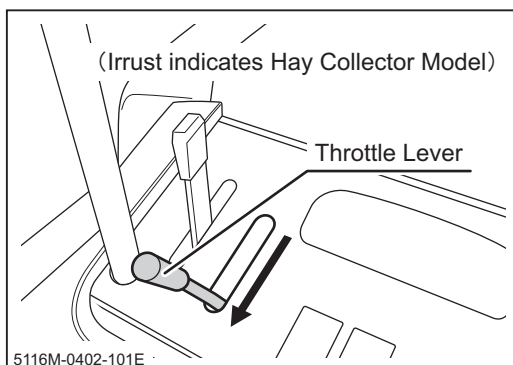

1. Move throttle lever to [🐇 (fast)] position to increase engine speed.



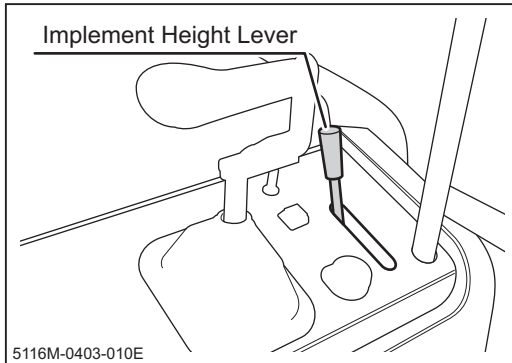

- Use implement height lever to set the desired cutting height.

#### NOTE

- Implement height lever sets the height to which implement can be lowered. It is useful when an uniform cutting height is required.

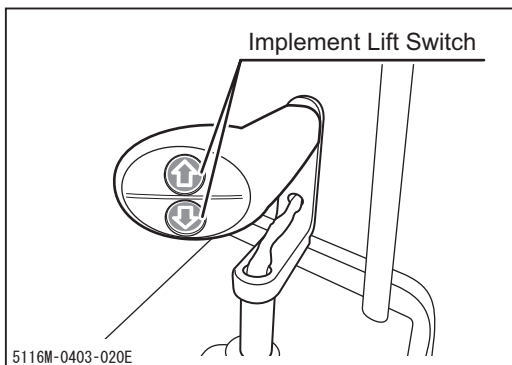

- Use implement lift switch to adjust the implement height.

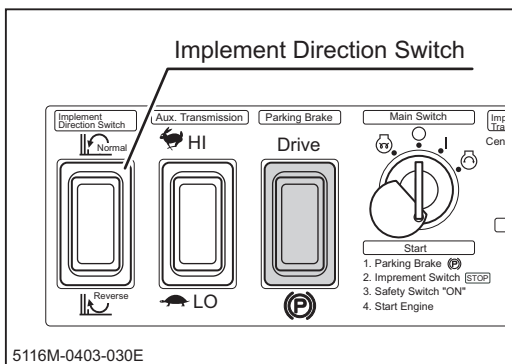

- Use implement direction switch to choose the direction of implement rotation.

#### NOTE

- Working in reverse rotation can reduce the amount of foreign objects such as pebbles to be scattered.
- Reverse rotation can be used only when implement is not translated to the side. If implement is translated and implement direction switch is in reverse, implement stops.
- When something gets tangled to implement, changing the rotating direction back and forth may help untangle.

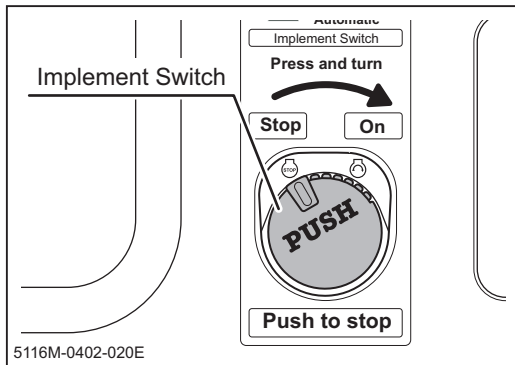

5. Push and turn implement switch to [RUN].
6. Drive machine forward to cut.

## NOTE

- If cutting load is high, reduce traveling speed or cut in stages at different cutting heights.

7. To stop implement, press implement switch; it automatically returns to [stop].

## Changing PTO Speed (Variable PTO Speed Model Only)

On Variable Speed PTO model, the PTO speed can be varied to meet requirements for different implements.

### ⚠ CAUTION!

- Use only the implements that are specifically designed and certified for this machine.
- Refer to the instructions for the specific implement.

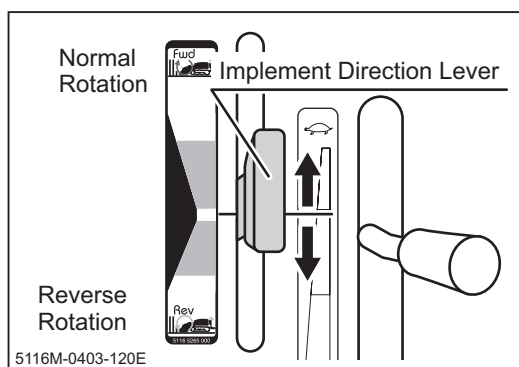

1. Move throttle lever to adjust engine speed.
2. Move implement direction lever to adjust the speed and direction of implement.

## Translating Implement

With this translation function, the entire implement can be translated to the right by 500mm at the maximum, allowing working on the edge of ditch or bank.

### ⚠ CAUTION!

- Always make certain of the safety of your surroundings before translating implement.
- Always lift up implement when translating. Translating implement while it is resting on the ground may cause damage.

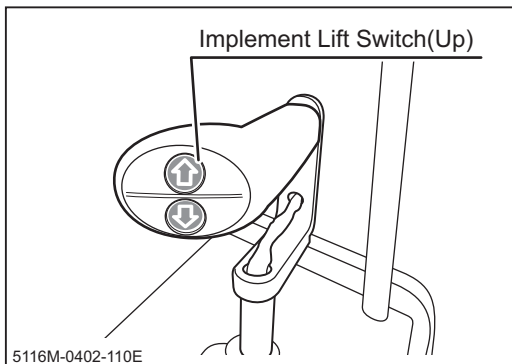

1. Press implement lift switch [UP] to lift implement off the ground.

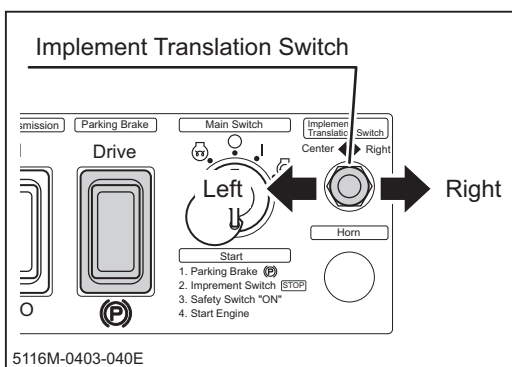

2. Tilt implement translation switch to [Right] to move implement to the right.
3. Tilt translation switch to [Center] to move it back to the original position.

### NOTE

- Implement does not translate when it is running.
- When implement direction is set in reverse, implement can only translate to 100mm to the right.
- When implement is translated and then implement direction switch is set in reverse, implement does not run.

## Maintenance Schedule

**⚠ WARNING!**

- Follow the scheduled maintenance as described below. Failure to do so may result in mechanical or property damage, injury or death.

- Perform a pre-startup inspection (PSI) before each use, a monthly inspection once a month, and a yearly inspection once a year.
- Some maintenance procedures described below may require special knowledge or tools and instruments. Contact your CANYCOM representative to perform such procedures.

Item	Description	Schedule			Note	
		PSI	Mon	Year		
<b>Hydraulic System</b>	<b>Plumbing</b>	Plumbing shall be free of cracks, damage, twists, or deterioration.	√	√	√	
		There shall be no leaks in pipes, hoses, joints, or seals.	√	√	√	
		Plumbing shall be mounted properly, and fastening bolts and nuts shall not be loose or missing.	√	√	√	
	<b>Motor</b>	Shall work normally.	√	√	√	
		Shall be firmly and properly mounted.		√	√	
		There shall be no leaks in pipes, hoses, joints, or seals.	√	√	√	
<b>Body, Chassis, Safety Devices</b>	<b>Panels</b>	Shall be free of cracks, deformation or corrosion.		√	√	
		Doors or lids shall open and close, and lock shall lock properly.		√	√	
		Fastening bolts or nuts shall not be loose or missing.	√	√	√	
	<b>Labels</b>	Warning labels and instruction plates shall be clean, legible, and free of damage.	√	√	√	
	<b>Rotor Indicator</b>	Rotor indicator shall illuminate when rotor is running.	√	√	√	

Item	Description	Schedule			Note	
		PSI	Mon	Year		
Cutting System	Cutting Rotor	Flails shall be free of crack or damage.	√	√	√	Inspecting/Changing: Page 19
		Shackles shall be free of crack or damage.	√	√	√	Inspecting/Changing: Page 19
		Shackle bolts shall be free of crack or damage.	√	√	√	Inspecting/Changing: Page 19
		Cutting rotor shields shall be free of crack or damage.	√	√	√	
		Rubber skirt shall be free of crack or damage.	√	√	√	
		Fastening bolts or nuts shall not be loose or missing.	√	√	√	
		Rotor drive belt tension shall be properly adjusted.	√	√	√	Inspecting/Adjusting: Page 21
		Rotor drive belt shall be free of damage, excessive wear, or dirt; shall be free of oil or grease.	√	√	√	Inspecting/Changing: Page 21
		Shall be sufficiently lubricated.		√	√	Greasing: Page 22
		Coupler	Pins shall be free of excessive wear and shall not be damaged or missing.	√	√	√
Arms shall be free of crack or damage or marked deformation.	√		√	√		
Rods shall be free of crack or damage or marked deformation.	√		√	√		
Hitch frame shall be free of crack or damage or marked deformation.	√		√	√		
Shall be sufficiently lubricated.			√	√	Greasing: Page 22	

## List of Fluids and Lubricants

Item	Schedule	Grade	Cap.
Drive Motor Lubricant	Change Initially - After 200 hours. Every 1000 hours afterwards.	Gear Oil API rating: GL-4 SAE rating: #90	0.6L
Grease	Every 100 hours.	Lithium all-purpose grease (NLG No.2 or equivalent)	-

## Grease Points

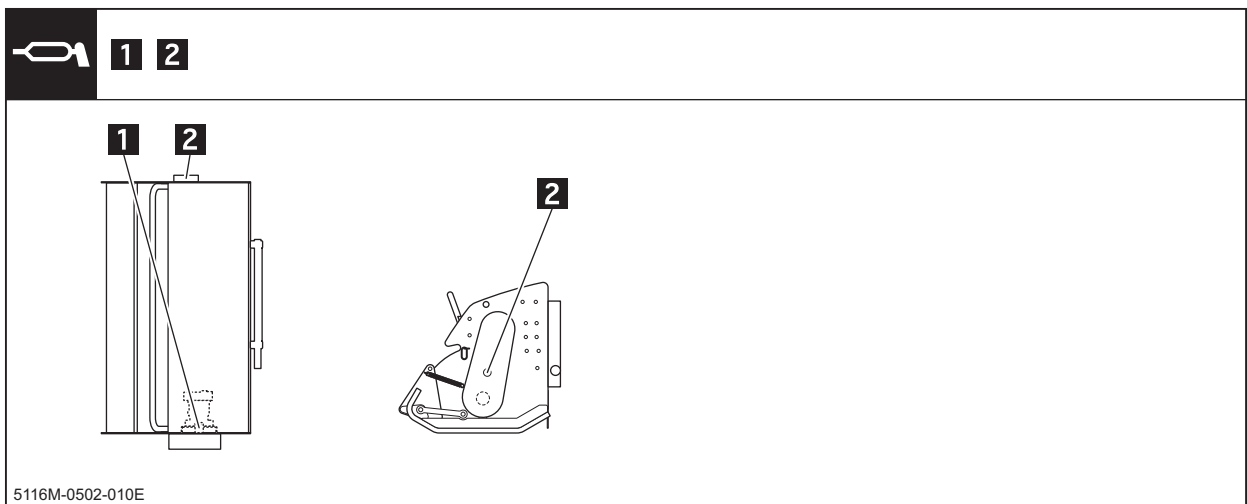

## List of Consumables and Spares

### **⚠ CAUTION!**

- Use only CANYCOM genuine parts when replacement or repair is required. CANYCOM assumes no liability whatsoever if any problem occurs as a result of using any part that is not a genuine CANYCOM part.

Item	Part No.	Schedule	Qty.
<b>Hydraulic System</b>			
Hoses (Rotor)	51166343000	Every 2 years or if defective.	2
	51166344000	Every 2 years or if defective.	1
	51166345000	Every 2 years or if defective.	2
	51166346000	Every 2 years or if defective.	1
	51166347000	Every 2 years or if defective.	1
	51166348000	Every 2 years or if defective.	1
<b>Cutting Rotor</b>			
Flail	51164165000	If defective.	80
Shackle	51164166000	If defective.	40
Bolt	51164167000	If defective.	40
Nylon Nut	51164168000	If defective.	40
V-Belt (Cutting Rotor)	51164169000	If defective.	3
Rotor	51164187100	If defective.	1

### NOTE

- Rubber products such as the hydraulic hose deteriorate over time. Replace them every 2 years.

## Body Panels

### **⚠ CAUTION!**

- Cut or pinch hazard exists when removing or installing body panels; beware of sharp edges and pinch points.
- Make certain to reinstall panels and closing doors after removing or opening for repairs or inspection.

## Opening Rotor Shield

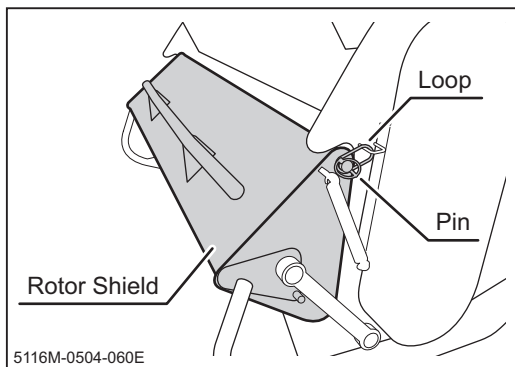

1. Lift up shield and hook loops to keep it in position. Insert pin through hole on both sides to secure shield.

## Removing Rotor Belt Cover

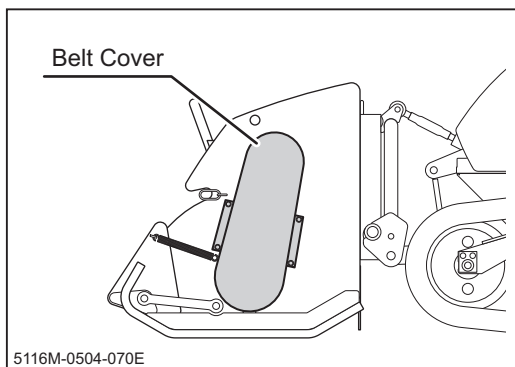

1. Undo 4 bolts to remove belt cover.



## Removing Upper Rotor Shield

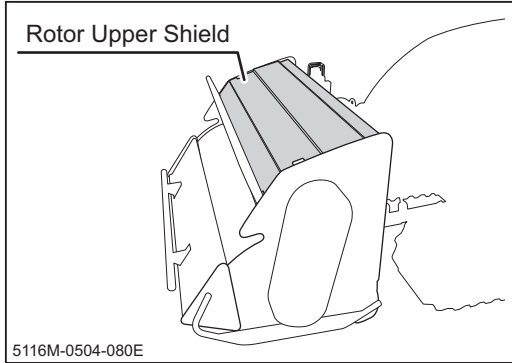

1. Undo 6 bolts to remove upper shield.

## Cutting System

### **⚠ WARNING!**

- Stop engine when servicing hydraulic system.
- Allow machine to cool off before servicing. Engine is very hot after operation and may pose a burn hazard.

## Flail

### **⚠ WARNING!**

- Do not go under cutting rotor unit.

### **⚠ CAUTION!**

- When a flail is damaged, replace it and its pair immediately. Always replace flails in pair. Damaged flail causes rotational imbalance and undue vibration, which can damage machine.
- When replacing flails, replace all flails at once. If it is necessary to replace only a part of flails, replace them in such a manner to keep left-to-right balance. Failure to do so can cause undue vibration and damage to machine.
- Flails have sharp edges. When replacing flails, wear thick gloves or wrap the flail with thick cloth and handle carefully.

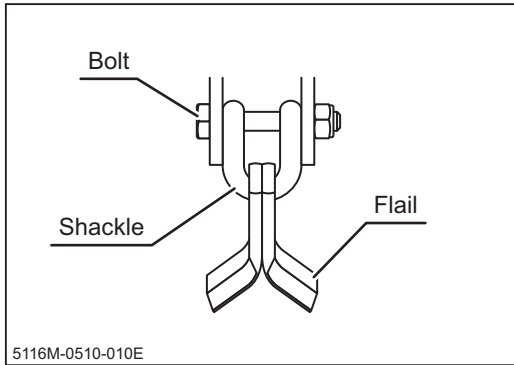

### Inspecting

1. Open cutting rotor shield and hold it in position firmly.
2. Visually inspect for wear and damage of flails or missing flails.
3. If flail, shackle or bolt is excessively worn, deformed, damaged, or missing, replace it with new one.
4. Close cutting rotor shield.

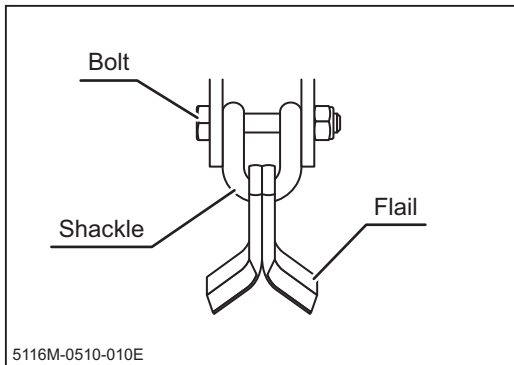

### Replacing

1. Undo bolt to remove shackle and flails.

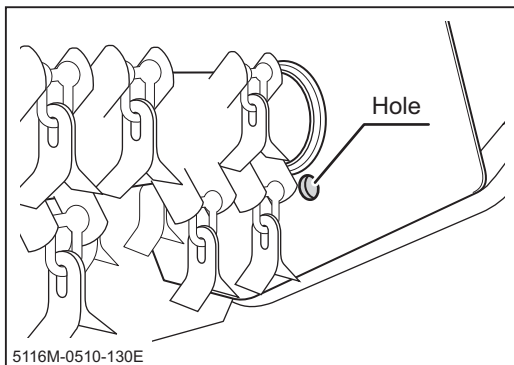

2. To remove flails on the extreme of either side, line up bolt with hole on side panel.
3. Install new flails.

### NOTE

- Flail has cutting edge on both sides. When one side wears out, flip flails to use the other side.
- Replacement flail: Page 16

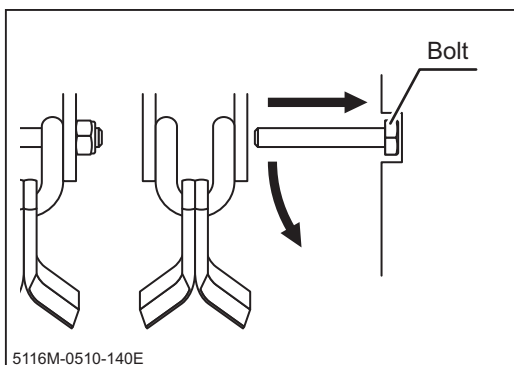

## Cutting Rotor Drive Belt

### ⚠ CAUTION!

- Adjust belt tension properly. Inproperly tensioned belt may reduce performance and its service life.

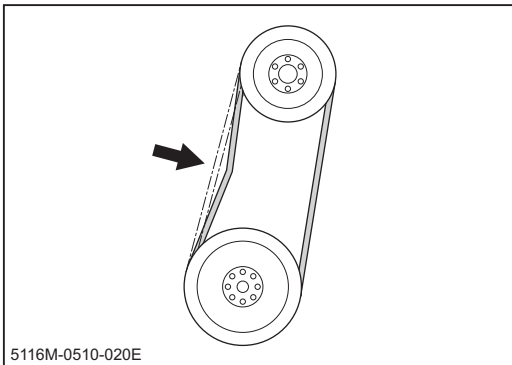

### Inspecting

1. Remove rotor belt cover.
2. Push in the middle of belt to check amount of bending. If it is not correct, adjust.
3. Install rotor belt cover.

### NOTE

- Amount of bending: 6.3mm with 10.8kgf

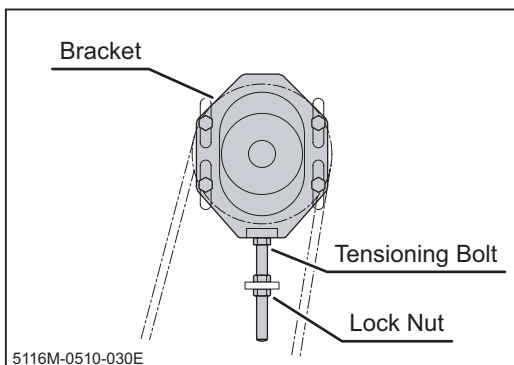

### Adjusting

1. Remove rotor upper shield and belt cover.
2. Loosen bracket mount bolts.
3. Loosen lock nut and adjust belt tension with tensioning bolt.
4. Tighten lock nut.
5. Tighten bracket mount bolts.
6. Test-drive rotor for a few minutes to make sure everything is tightly secured.
7. Install upper rotor shield and belt cover.

## Greasing

### ⚠ CAUTION!

- Follow the maintenance schedule to grease up machine. Lack of greasing may result in rust, excessive wear or seizure.

### NOTE

- When using a manual grease gun, pump 5-6 times. When the handle of the gun becomes heavy, stop pumping immediately.
- When using a pneumatic grease gun, pump it for a few seconds.
- Grease to use: Page 15

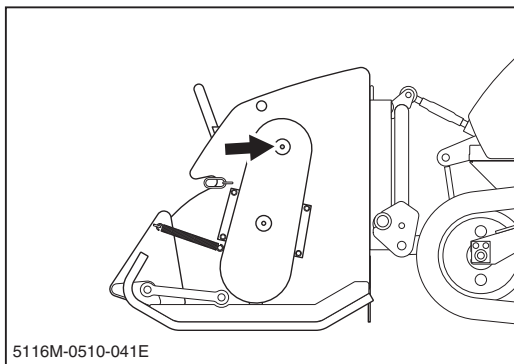

#### Rotor Drive Motor

1. Grease rotor drive motor with grease gun.

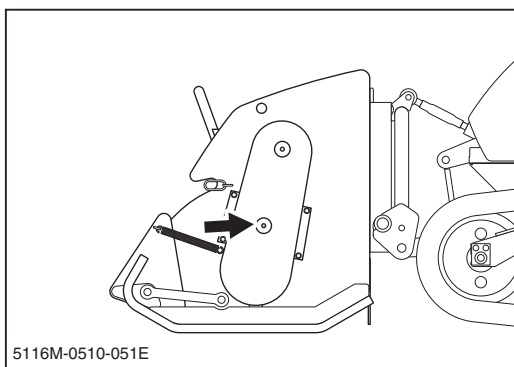

#### Rotor Axle (Left)

1. Grease rotor axle (left) with grease gun.

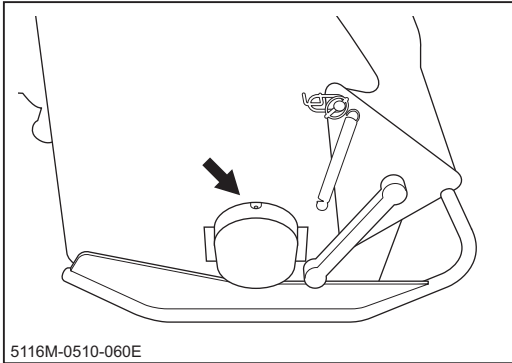

## Rotor Axle (Right)

1. Grease rotor axle (right).

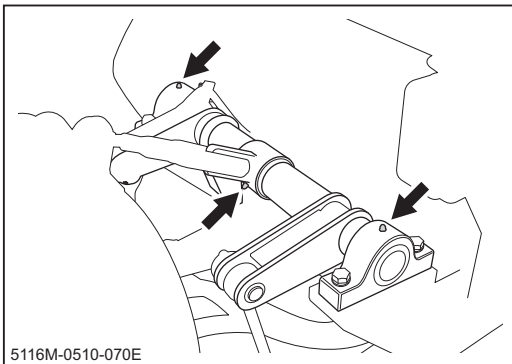

## Three-point Hitch Links and Bearings

1. Grease bearings and links on three-point hitch.

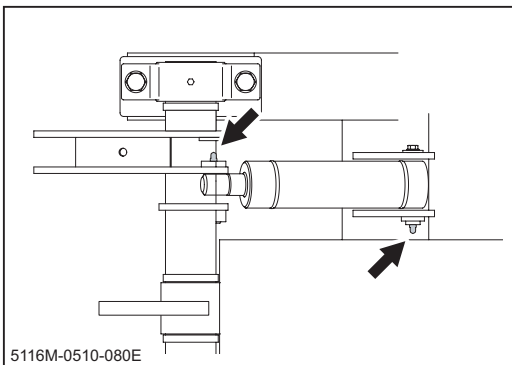

## Cylinder Pins

1. Grease pins on the ends of hydraulic cylinder.

## Attaching/Detaching Implement

### **⚠ WARNING!**

- Park machine on a level surface when attaching or detaching implement.
- Do not go under implement.
- Always release residual pressure of hydraulic components when detaching implement, or oil under high pressure may leak and penetrate through skin and cause injury upon contact.
- Hydraulic fluid is very hot right after use. Allow hydraulic fluid to cool before detaching implement, or severe burns may result.

### **⚠ CAUTION!**

- Never turn cutting on rotor switch when quick couplers are detached. Hydraulic components or plumbing can be damaged.

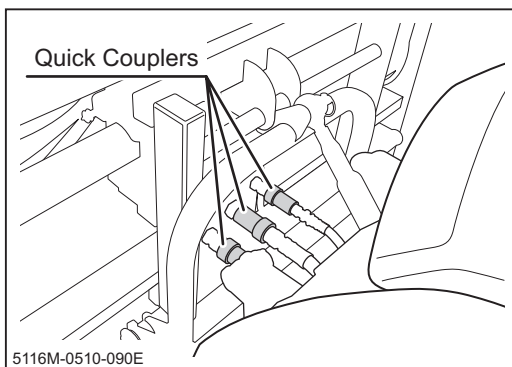

1. Park machine on a level surface.
2. Lower implement until it rests on the ground.
3. Detach quick couplers on hydraulic hoses.

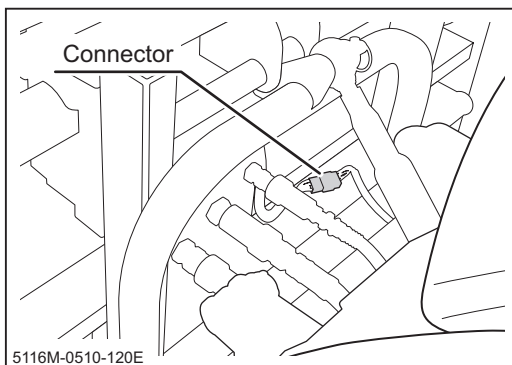

4. Detach connector on wiring harness.

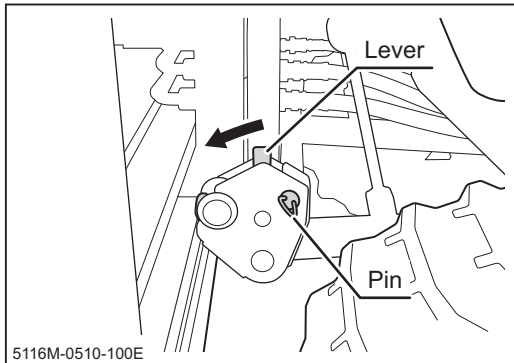

5. Remove link pins and pins. (2 places on both sides.)
6. Fold down lever to unlock.

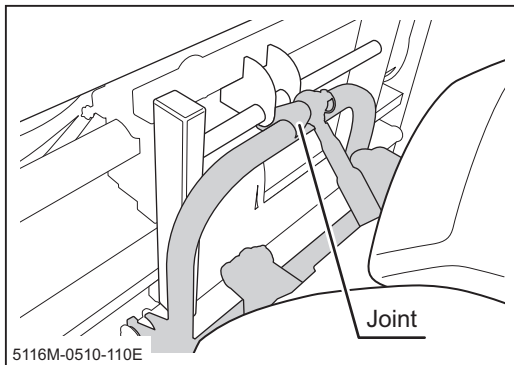

7. Lower link to unhook.
8. Drive backwards to remove implement.



## After Use Care

### **⚠ CAUTION!**

- Do not wash engine, control panel, electrical parts, or tank caps with air breather with running water; water may enter inside and cause rust or damage.
- Clean machine after use; leaving dirt or foreign objects may cause damage.
- Do not attempt to move machine when it becomes inoperable due to freezing.

## After Normal Use

1. Clean machine; wash off dirt, mud, and other foreign matter after use.
2. If machine is to be left outside, cover machine with protective, water-proof covering after machine is cooled off.

## After Cold Weather Use

1. Clean machine; wash off dirt, mud, and other foreign matter after use.
2. Park machine on a paved or firm, dry surface.
3. If machine is to be left outside, cover machine with protective, water-proof covering after it is cooled off.

## Storage

### **⚠ WARNING!**

- Fire hazard; do not store machine where there is a possibility of ignition.

### **⚠ CAUTION!**

- Do not wash engine or control panel with running water; water may enter inside and cause rust or damage.
- Clean machine before storage; leaving dirt or foreign objects may cause rust or damage.
- Do not store machine in a humid, dusty, or hot place.

1. Park machine.
2. Clean dirt off of machine.
3. Check machine according to **Maintenance Schedule** chart (Page 13) and service as necessary.
4. Clean steel parts of machine with oil-soaked rag. Grease greasing points.
5. Change engine oil.
6. Completely drain coolant from engine cooling system.
7. Clean air cleaner.
8. Drain fuel from fuel tank.
9. Remove battery from machine. Service battery.
10. Cover machine with protective, water-proof covering after machine is cooled off.

### **NOTE**

- Battery discharges even when it is not in use. A battery may hold charge for a few months, but it is a good practice to charge battery before it goes flat; it will extend the battery life.
- Refer to the Operation Manual for the engine, for detailed instructions on preparing engine for storage.

## Troubleshooting

- If any malfunction or abnormal condition is found, immediately stop using the machine and take an appropriate measure according to the Troubleshooting chart below. If the malfunction or abnormal condition is not listed in the chart, or the suggested measure does not solve the problem, consult with your CANYCOM representative.
- Some corrective measures listed below require special knowledge and/or equipment. Please contact your CANYCOM representative in such a case.

Area	Malfunction	Possible Cause	Corrective Measure	Ref.
Cutting System	Cutting rotor does not run	Belt is not properly adjusted.	→Fill fuel.	
		Belt is severed.	→Drain water.	
		Faulty hydraulic system.	→Fill or change oil.	
		Other (other than the above).	→Follow the instructions in "Working" to operate the machine. If problem persists, please contact your CANYCOM representative.	Page 8
	Cutting rotor vibrates excessively when it is run.	Broken flail(s).	→Replace.	Page 19
		Foreign object is tangled.	→Untangle.	
		Other (other than the above).	→Please contact your CANYCOM representative.	

## Hoisting

### **⚠️ WARNING!**

- Hoisting may require appropriate training or licence. Consult with your local authority.
- Use hoisting sling of sufficient strength. Always use slings of the same length when more than one is used.
- Pay attention to the balance and the location of the center of gravity of machine.

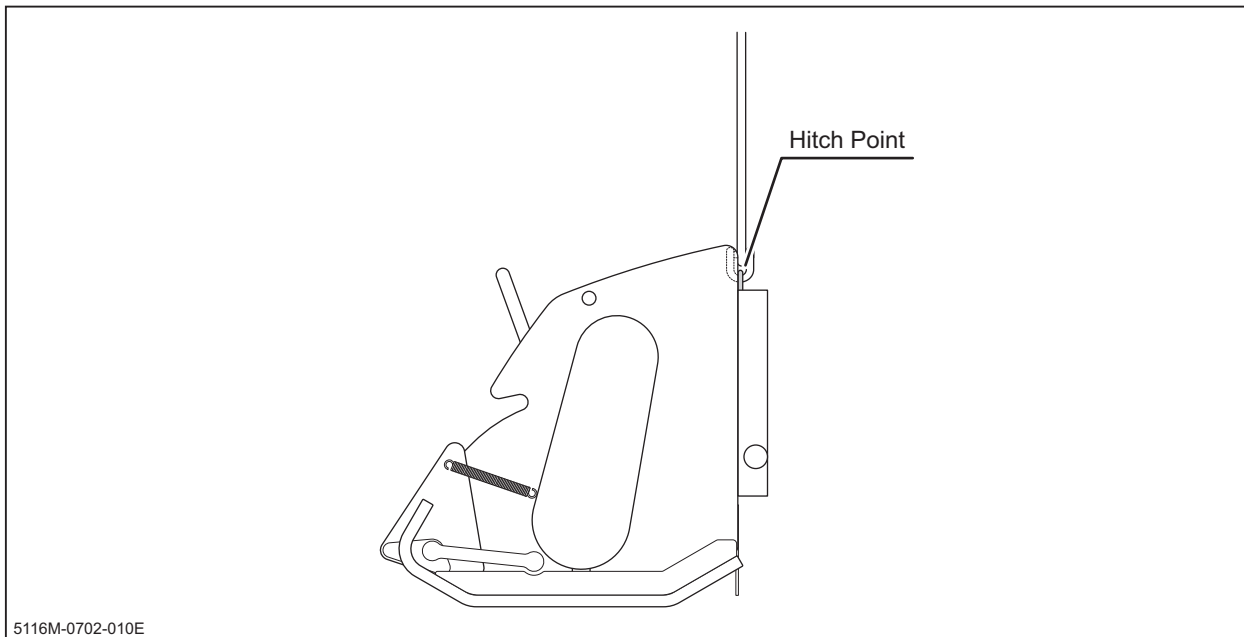

1. Attach hoisting slings to hitch points of mower. Hoist the center of slings.