

5313 830A シャフト2クミタテ SECOND SHAFT EQUIPMENT

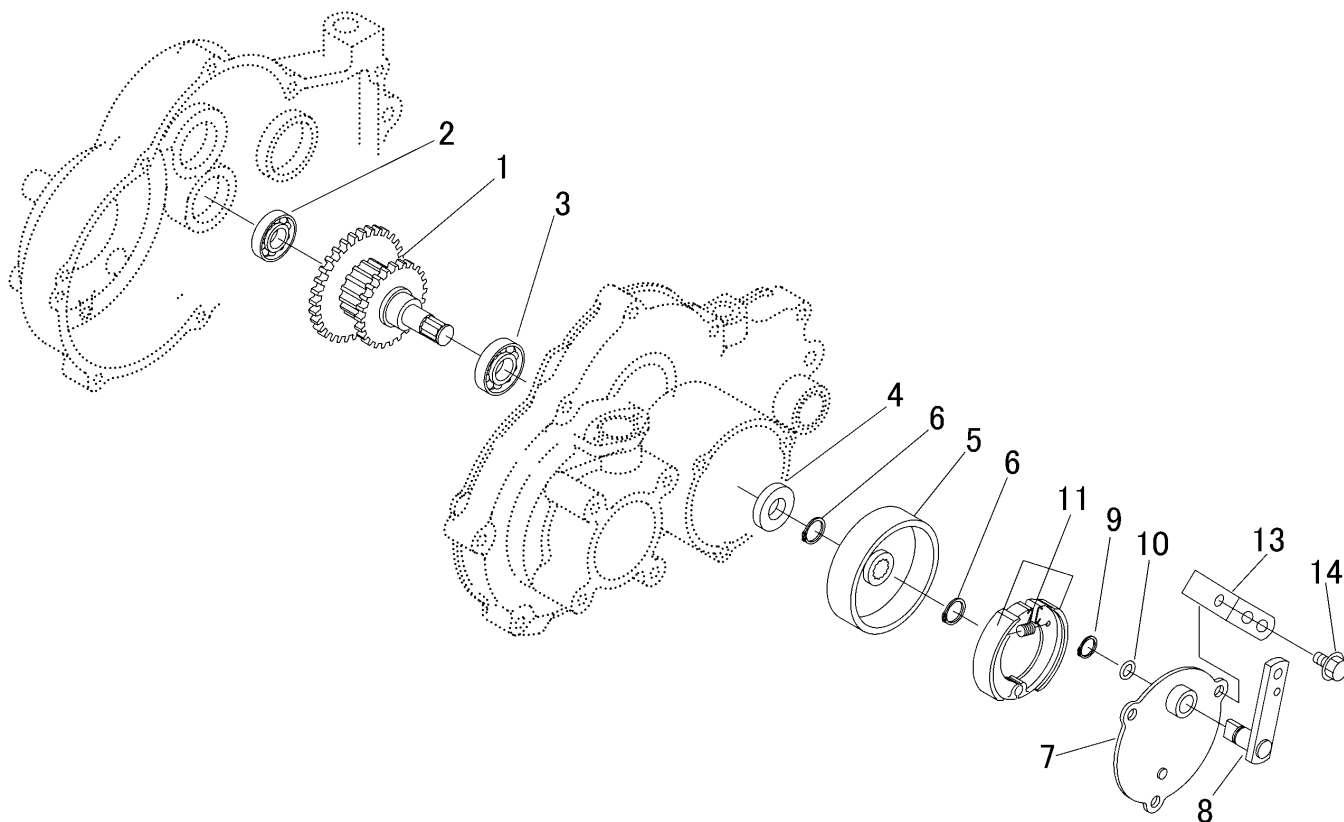

見出 NO.	部品番号 PART NO.	部品名称	PART NAME	個数 Q'ty	型 寸 DESCRIPTION	適用号機 FROM ~ UP TO SERIAL NO.	備 考 REMARKS
1	5313 8301 000	シャフト	SHAFT	1			
2	0750 0060 040	ﾊﾞｰﾘﾝｸﾞ	BEARING	1	6004		
3	0750 0060 050	ﾊﾞｰﾘﾝｸﾞ	BEARING	1	6005		
4	0840 1017 357	ｵｲﾙｼｰﾙ	SEAL OIL	1	UE17X35X7		
5	7306 4005 011	ﾌﾞﾚｰｷﾄﾞﾗﾑ	DRUM	1			
6	0740 0001 600	ﾘﾝｸﾞ	RING	2	S16		
7	7306 4009 000	ﾊﾞｯｷﾝｸﾞﾌﾟﾚｰﾄ	PLATE	1			
8	7306 4015 000	ﾌﾞﾚｰｷﾚﾊﾞ -	LEVER	1			
9	0740 0001 400	ﾘﾝｸﾞ	RING	1	S14		
10	0830 0500 120	ｵﾘﾝｸﾞ	O RING	1	S12		
11	7306 9901 000	ｼｰﾙ	SHOE set	1			
13	5313 8311 000	ﾌﾟﾚｰﾄ	PLATE	1			
14	K110 0108 016	ﾌﾞｰﾙﾄ	BOLT	3	M8 x 16(4T)		