

5332 200B ミッション (チャージポンプ付) Transmission (With Charge Pump)  
 减速机组装 (含电荷泵)

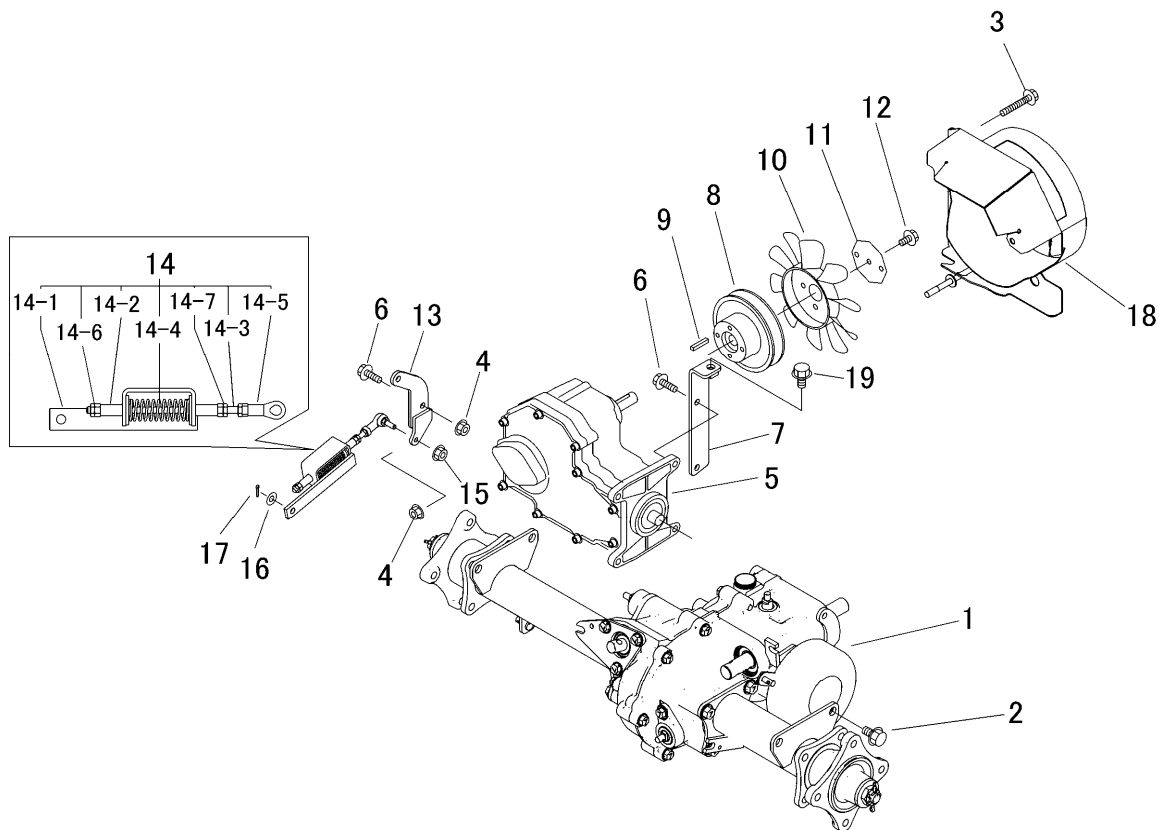

見出	部品番号	部品名称			個数	型 寸	互	適用号機	備 考
图片号码	零件号码		零件名称		数量	尺 寸	换	适用机型	备注
NO.	PART NO.	PART NAME			Q'ty	DESCRIPTION	R/P	FROM ~ UP TO SERIAL NO.	REMARKS
1	5332 800A 000	ミッションAssy	TRANSMISSION	减速机总装	1				
2	K710 0112 020	Fボルト	BOLT	螺栓	4	M12×20(P=1.75)		~NO.1850368	
2	K712 0112 025	Fボルト	BOLT	螺栓	4	M12×25(P=1.25)	D	NO.1850369~	
3	K814 0108 050	Fボルト	BOLT	螺栓	2	M8×50			
4	F301 0108 000	Fナット	NUT	螺母	4	M8			
5	5316 8105 001	HST	HST	HST装置总装	1	BDR-322			
6	K710 0108 025	Fボルト	BOLT	螺栓	5	M8×25(7T)			
7	5332 2003 000	プレート	PLATE	铁板	1				
8	3557 2031 001	プーリ	PULLEY	滑轮	1				
9	0572 0005 028	キー	KEY	销	1	5×28			
10	7306 1137 000	クーリングファン	FAN	冷却器	1				
11	5332 2004 000	プレート	PLATE	铁板	1				
12	K710 0106 014	Fボルト	BOLT	螺栓	5	M6×14			
13	5332 2005 000	リンク	LINK	连接	1				
14	5332 2008 000	HSTニュートラルアッソ	NEUTRALASSY	HST装置总装	1				
14-1	5332 2009 000	ブラケット	BRACKET	支架	1				
14-2	5310 3108 000	ガイド	GUIDE	导管	2				
14-3	5310 3109 000	ボルト	BOLT	螺栓	1				
14-4	5310 3109 500	スプリング	SPRING	弹簧	1				
14-5	3652 0702 000	リンクボール	JOINT	环状接头	1	M6			
14-6	A300 0106 001	ナット	NUT	螺母	2	M6			
14-7	A300 0106 003	ナット	NUT	螺母	3	M6			
15	F300 0106 000	Fナット	NUT	螺母	3	M6			
16	0350 0140 818	PW	WASHER	垫圈	1	8×18×1.6			
17	0520 0125 016	ワピン	PIN SPLIT	开销	1	2.5×16			