

目次

Table of Contents

5333	805A	ケース CASE	1
5332	810A	ダイ2ジク SECOND SHAFT	2
5332	812A	ダイ1ジク FIRST SHAFT	3
5347	813A	アクスル AXLE	4
5332	816A	デフ DIFFERENTIAL GEAR	5
5332	817A	ブレーキ BRAKE	6
5332	821A	シフター SHIFTER	7
5332	822A	デフシフト DIFF SHIFT	8
5347	849A	カリハジク BLADE SHAFT	9

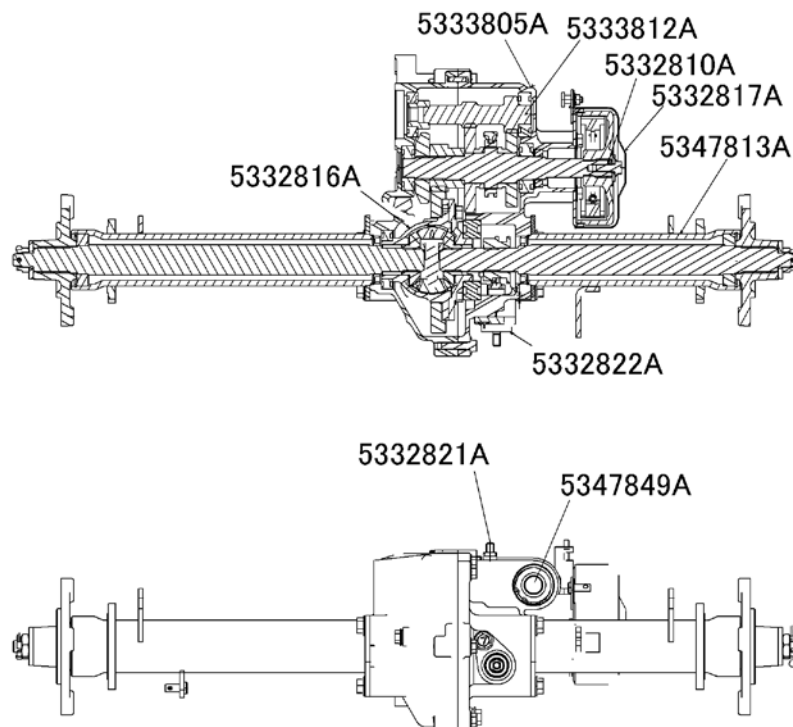

5333 805A ケース CASE

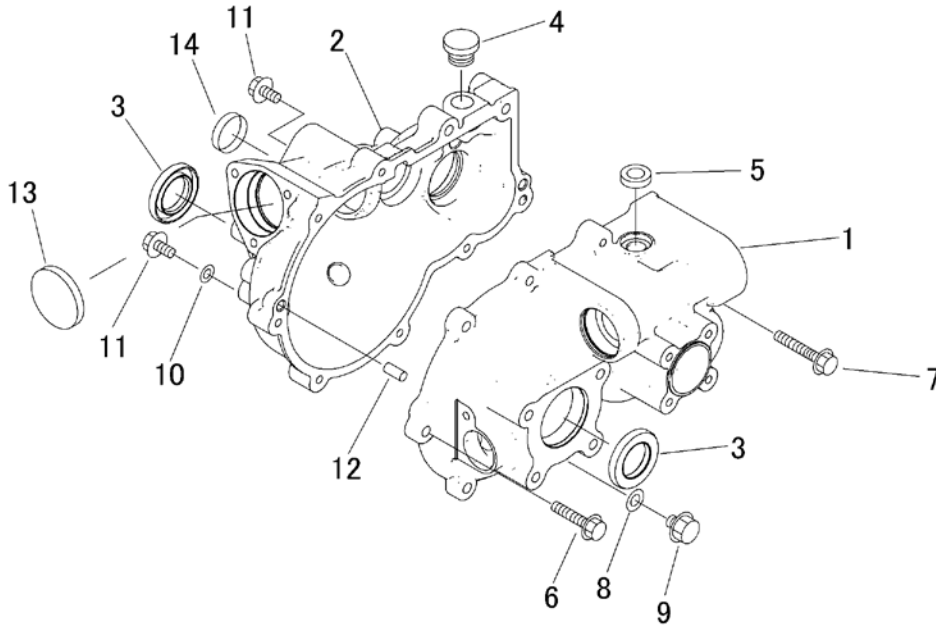

見出	部品番号	部品名称		個数	型 寸	互換性	適用号機	備 考
NO.	PART NO.	PART NAME		Q'ty	DESCRIPTION	R/P	FROM ~ UP TO SERIAL NO.	REMARKS
1	5332 8001 000	ケース	CASE	1				
2	5332 8002 000	ケース	CASE	1				
3	0840 1030 508	オイルシール	SEAL OIL	2	UE30*50*8			
4	7410 1004 000	チュウユセン	CAP	1				
5	0840 1014 246	オイルシール	SEAL OIL	1	UE14*24*6			
6	K710 0108 030	Fボルト	BOLT	6	M8*30(7T)			
7	K710 0108 050	Fボルト	BOLT	3	M8*50(7T)			
8	0833 0001 000	シールワツシヤ	SEAL WASHER	1	SW-10			
9	K712 0110 012	Fボルト	BOLT	1	M10*12 P=1.25			
10	0833 0000 800	シールワツシヤ	SEAL WASHER	1	SW-8			
11	K710 0108 016	Fボルト	BOLT	2	M8*16			
12	0541 1108 018	ヘイコウピン	PIN	2	8*18			
13	0834 0052 070	シールキャップ	SEAL CAP	1	52*7			
14	0834 0032 070	シールキャップ	SEAL CAP	1	32*7			

5332 810A ダイゾク SECOND SHAFT

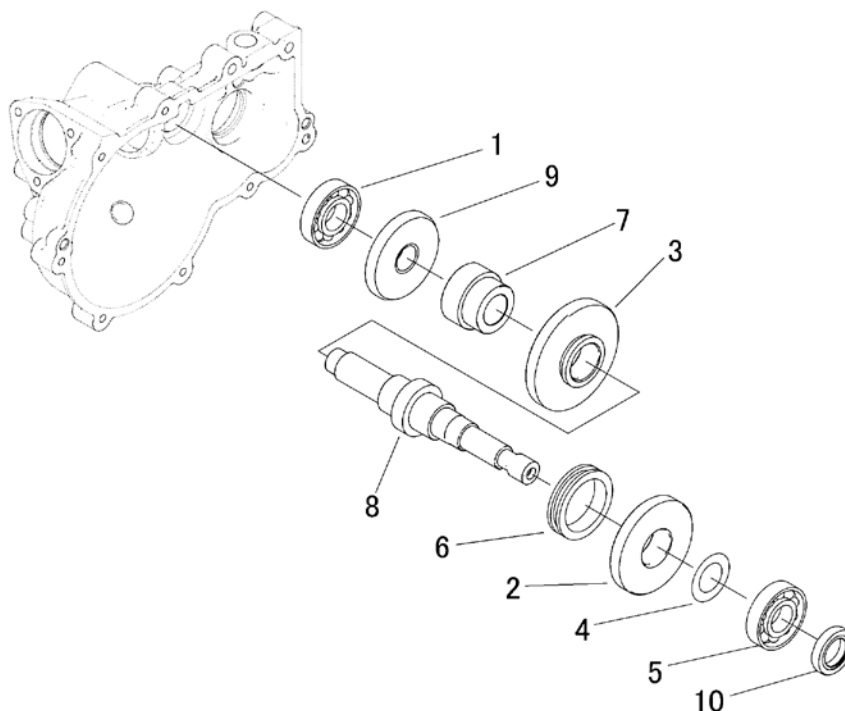

見出	部品番号	部品名称		個数	型 寸	互 換 性	適 用 号 機	備 考
NO.	PART NO.	PART NAME		Q'ty	DESCRIPTION	R/P	FROM ~ UP TO SERIAL NO.	REMARKS
1	0750 0062 040	ベアリング	BEARING	1	6204			
2	5332 8123 000	ギヤ 39	GEAR 39	1				
3	5332 8122 000	ギヤ 45	GEAR 45	1				
4	7202 2503 000	shim B	SHIM	1				
5	0750 0062 050	ベアリング	BEARING	1	6205			
6	5321 8124 000	クラッチ	CLUTCH	1				
7	5332 8125 000	ギヤ 14	GEAR 14	1				
8	5332 8121 000	シャフト	SHAFT	1				
9	5332 8126 000	ベベルギヤ 31	GEAR 31	1				
10	0840 1024 408	オイルシール	SEALOIL	1	UE24*40*8			

5332 812A ダイ1ジク FIRST SHAFT

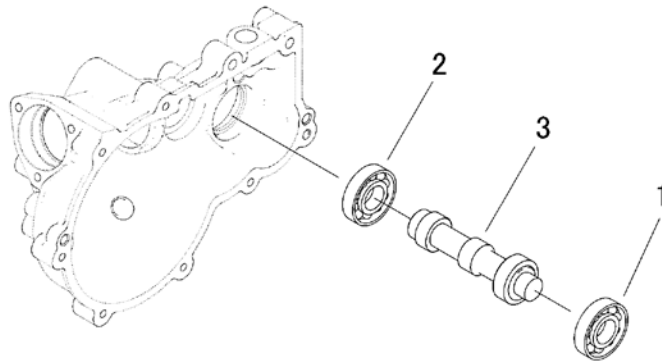

見出	部品番号	部品名称			個数	型 寸	互換性	適用号機	備 考
NO.	PART NO.	PART NAME			Q'ty	DESCRIPTION	R/P	FROM ~ UP TO SERIAL NO.	REMARKS
1	0750 0062 040	ベアリング	BEARING		1	6204			
2	0750 0060 050	ベアリング	BEARING		1	6005			
3	5332 8201 000	ギヤ 11-17	GEAR 11-17		1				

5347 813A アクスル AXLE
RH

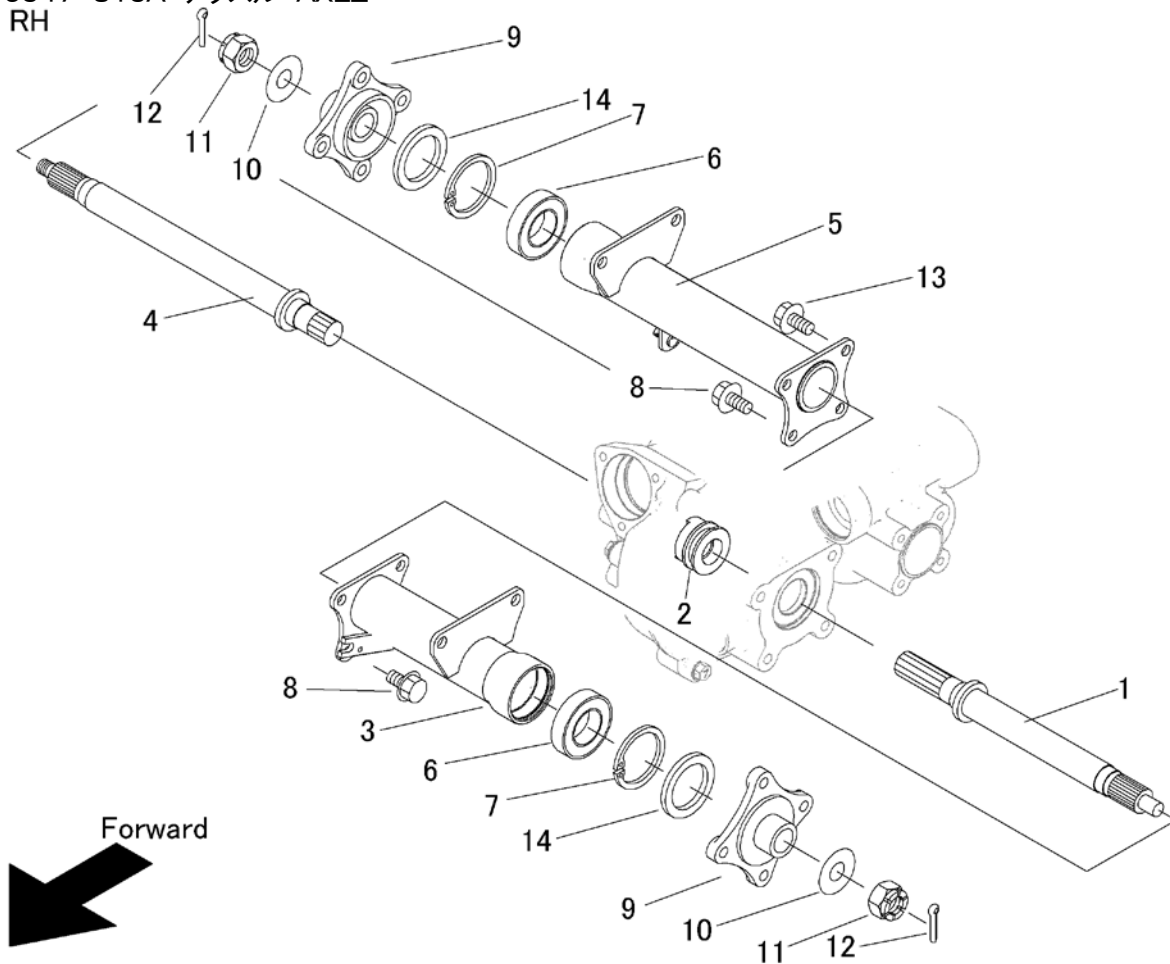

見出	部品番号	部品名称		個数	型 寸	互換性	適用号機	備 考
NO.	PART NO.	PART NAME		Q'ty	DESCRIPTION	R/P	FROM ~ UP TO SERIAL NO.	REMARKS
1	5347 8141 000	シャフト	SHAFT	1				ストップ付
2	5332 8133 000	デフロックツメ	CLUTCH	1				
3	5347 8143 000	パイプ	PIPE	1				ストップ付
4	5347 8142 000	シャフト	SHAFT	1				ストップ付
5	5347 8147 001	パイプ	PIPE	1				ストップ付
6	0750 0560 064	ベアリング	BEARING	2	6006DDU			
7	0741 0005 500	Oリング	RING	2	H55			
8	K712 0610 025	Fボルト	BOLT	7	M10*25			
9	5347 8136 000	ハブ	HUB	2				カバー付
10	0350 0171 640	PW	WASHER	2	16*40*4.5			
11	A312 0101 621	キャスルナット	NUT	2	M16			
12	0520 0140 032	ワリピン	PIN SPLIT	2	4.0*32			
13	K712 0610 020	Fボルト	BOLT	1	M10x20			
14	5332 8135 000	オイルシール	SEAL OIL	2	40*55*5			

5332 816A デフ DIFFERENTIAL GEAR

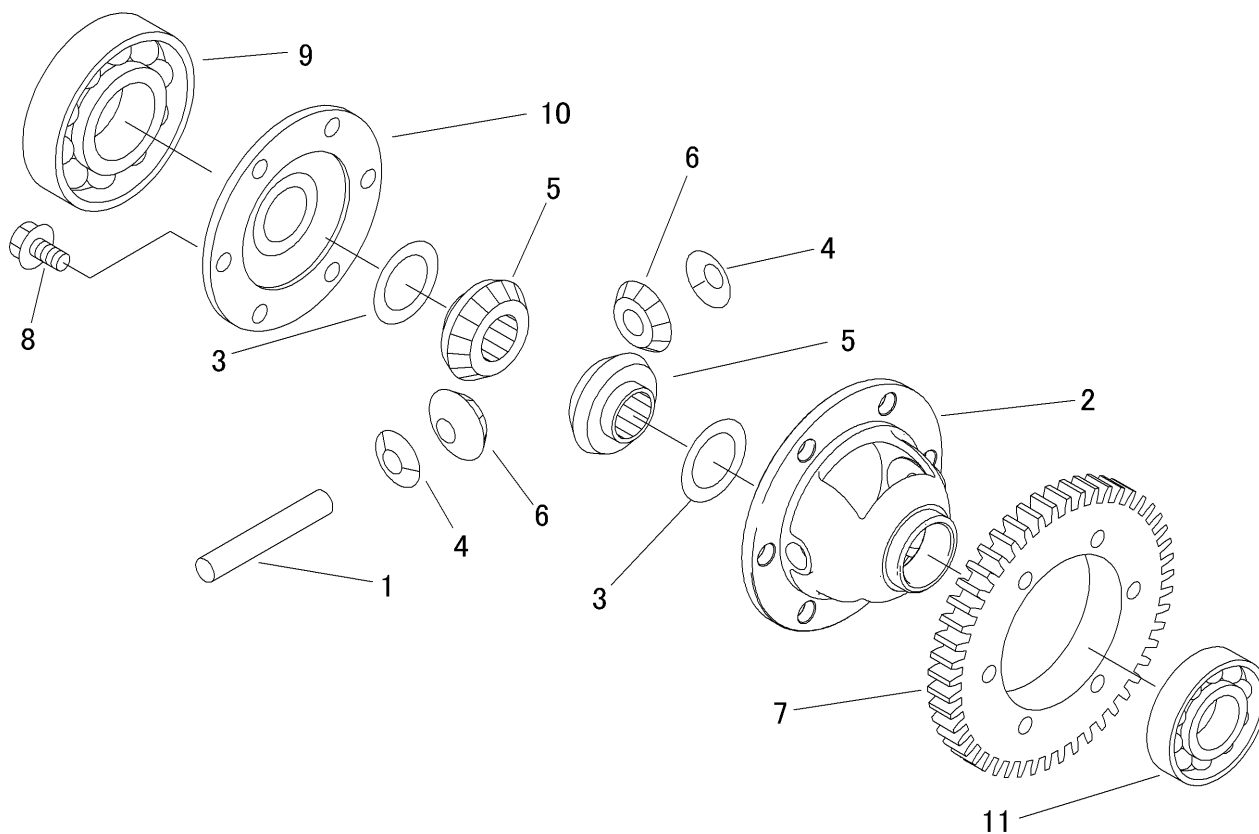

見出	部品番号	部品名称		個数	型 寸	互換性	適用号機	備 考
NO.	PART NO.	PART NAME		Q'ty	DESCRIPTION	R/P	FROM ~ UP TO SERIAL NO.	REMARKS
1	7201 2607 000	ピニオンシャフト	SHAFT	1				
2	5332 8162 000	デフケーシング	CASE	1				
3	7201 2608 000	シムC	SHIM	2				
4	7201 2609 000	シムD	SHIM	2				
5	5332 8164 000	ベベルギヤ	GEAR	2				
6	5332 8165 000	ベベルギヤ	GEAR	2				
7	5332 8131 000	ギヤ 50	GEAR 50	1				
8	K712 0610 025	Fボルト	BOLT	6	M10*25			
9	0750 0062 090	ベアリング	BEARING	1	6209			
10	5332 8163 000	デフフランジ	DIFF FLANGE	1				
11	0750 0069 080	ベアリング	BEARING	1	6908			

5332 817A ブレーキ BRAKE

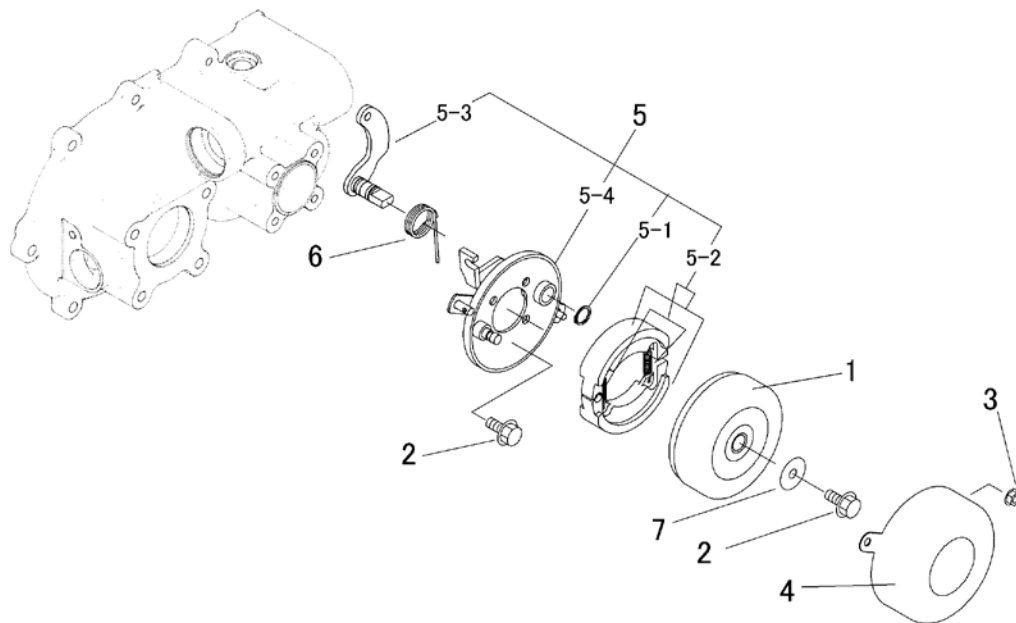

見出	部品番号	部品名称			個数	型 寸	互換性	適用号機	備 考
NO.	PART NO.	PART NAME			Q'ty	DESCRIPTION	R/P	FROM ~ UP TO SERIAL NO.	REMARKS
1	7201 4061 000	ブレーキドラム	DRUM		1				
2	K710 0608 020	Fボルト	BOLT		5	M8*20(7T)			
3	F300 0106 000	ナット	NUT		2	M6			
4	5332 8175 000	カバー	COVER		1				
5	5332 8172 001	ブレーキ	BRAKE		1				
5-1	0740 0001 600	Cリング	RING		1	S16			
5-2	7301 9901 000	シューセット	SHOE set		1				
5-3	5332 8171 000	レバー	LEVER		1				
5-4	5332 8173 001	ブレーキ	BRAKE		1				
6	5332 8177 100	スプリング	SPRING		1				
7	0350 0160 828	PW	WASHER		1	8*28*3.0			

5332 821A シフター SHIFTER

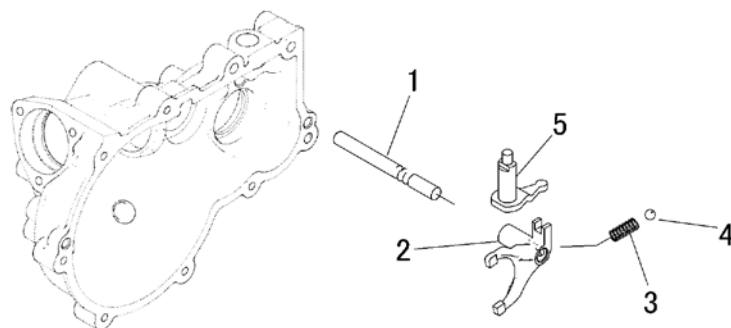

見出	部品番号	部品名称			個数	型 寸	互 換 性	適用号機	備 考
NO.	PART NO.	PART NAME			Q'ty	DESCRIPTION	R/P	FROM ~ UP TO SERIAL NO.	REMARKS
1	5332 8181 000	シャフト	SHAFT		1				
2	5332 8022 000	フォーク	FORK		1				
3	7305 3008 000	スプリング	SPRING		1				
4	0800 0000 800	ボール	BALL		1	(5/16)			
5	5332 8214 000	レバー	LEVER		1				

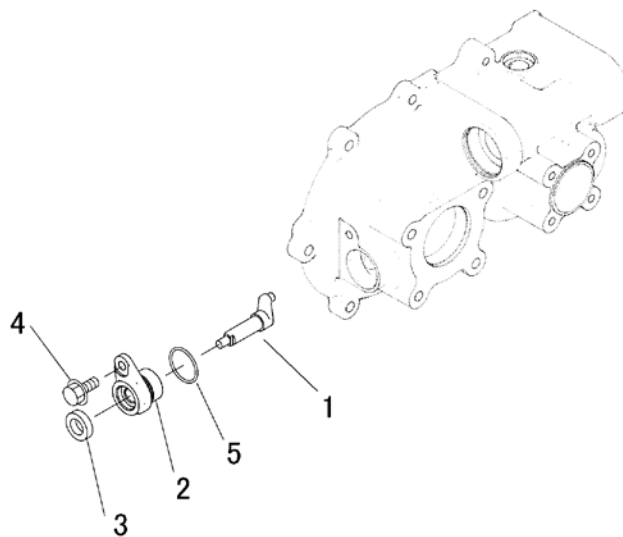

見出 NO.	部品番号 PART NO.	部品名称 PART NAME		個数 Q'ty	型 寸 DESCRIPTION	互 換 性 R/P	適 用 号 機 FROM ~ UP TO SERIAL NO.	備 考 REMARKS
1	5332 8222 000	シフター	SHFTER	1				
2	5332 8221 000	ボス	BOSS	1				
3	0840 1014 246	オイルシール	SEAL OIL	1	UE14*24*6			
4	K710 0108 016	Fボルト	BOLT	1	M8*16(7T)			
5	0830 0500 290	Oリング	O RING	1	S29			

5347 849A カリハジク BLADE SHAFT

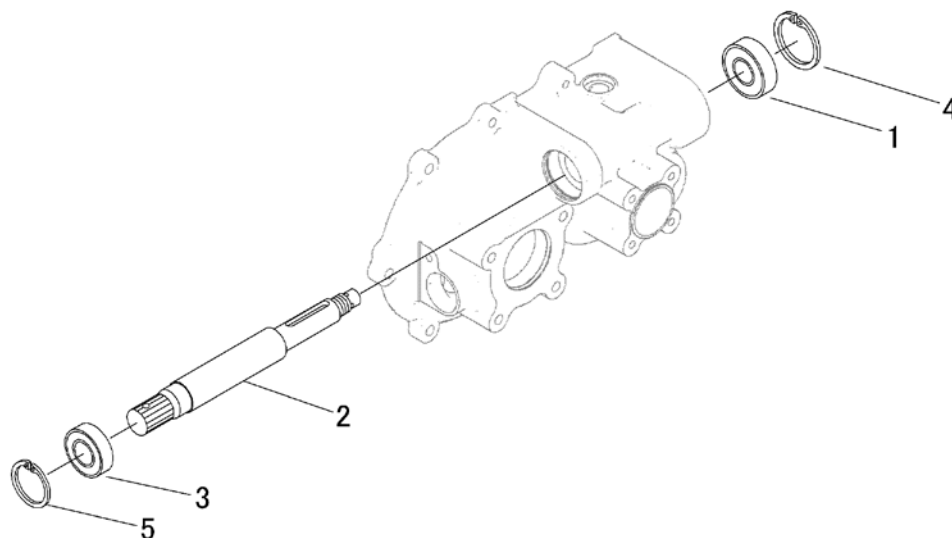

見出	部品番号	部品名称		個数	型 寸	互	適 用 号 機	備 考
NO.	PART NO.	PART NAME		Q'ty	DESCRIPTION	R/P	FROM ~ UP TO SERIAL NO.	REMARKS
1	0750 0562 044	ベアリング	BEARING	1	6204DDU			
2	5332 2451 000	ピン	PIN	1				旧部品
2	5347 8491 000	ピン	PIN	1		D		新部品
3	0750 0560 044	ベアリング	BEARING	1	6004			旧部品
3	0750 0569 054	ベアリング	BEARING	1	6905	D		新部品
4	0741 0004 700	Oリング	RING	1	H47			
5	0741 0004 200	Oリング	RING	1	H42			

注) 旧部品は、赤色プロペラシャフト用 新部品は、黄色プロペラシャフト用