

Robin Engine

PARTS CATALOG

MODEL EX170

SPEC.NO EX170DS7020

ご注文の際は部品番号の前に **ZR** をご記入下さい。

富士重工業株式会社
FUJI HEAVY INDUSTRIES LTD.

FIG. 100

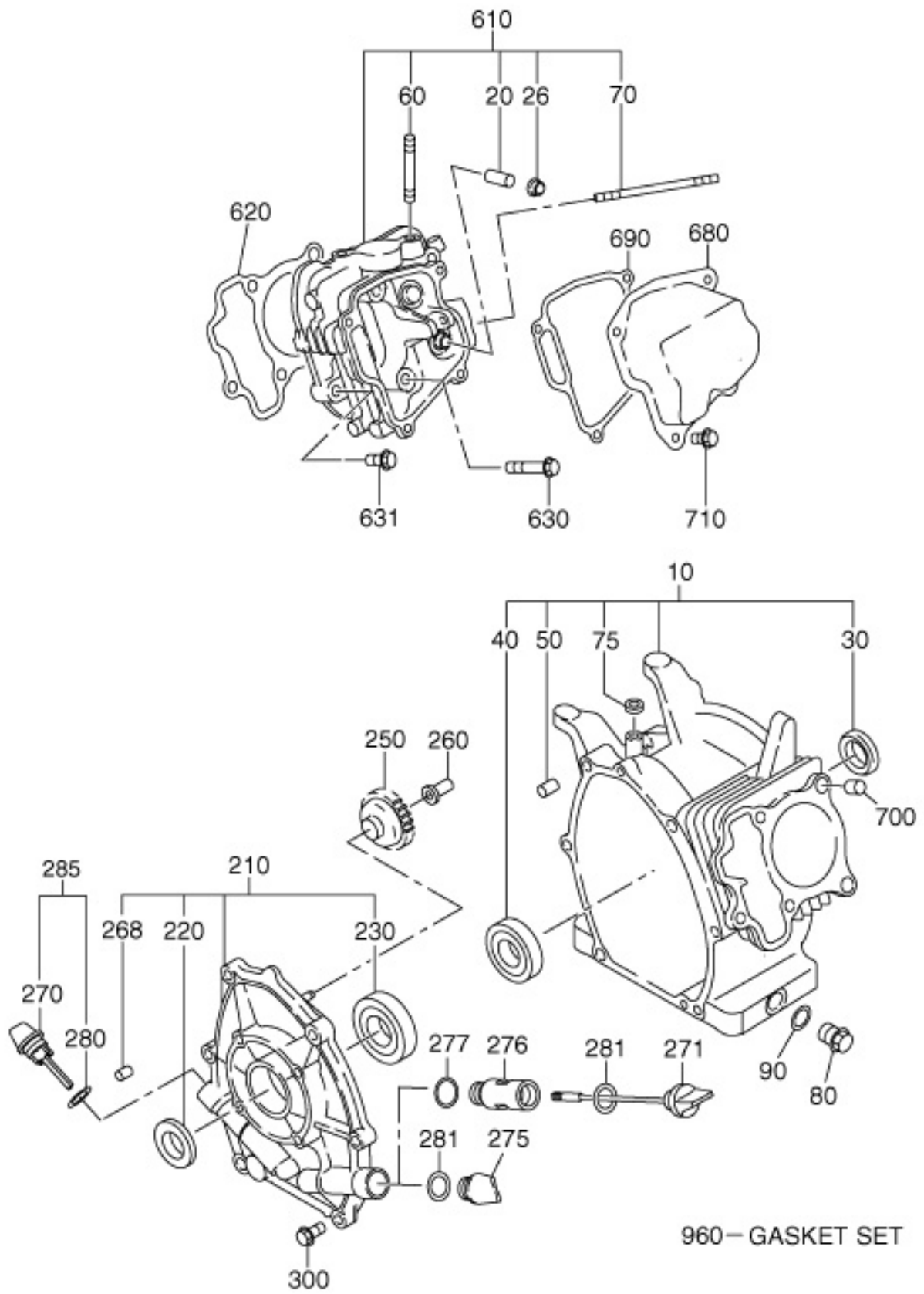

FIG. 200

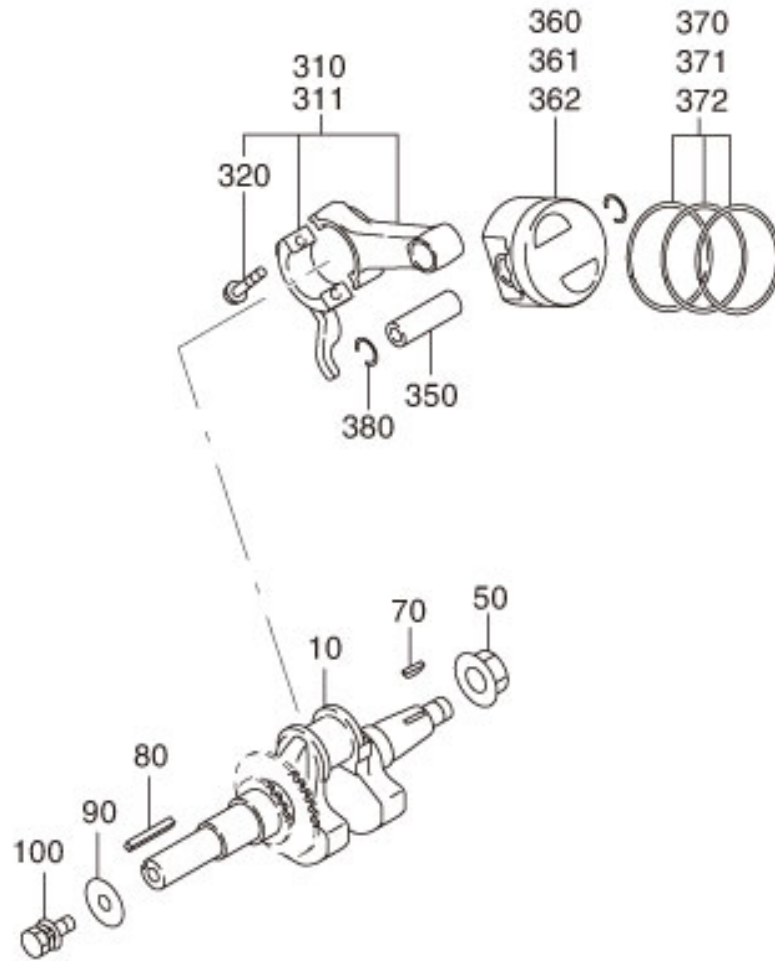
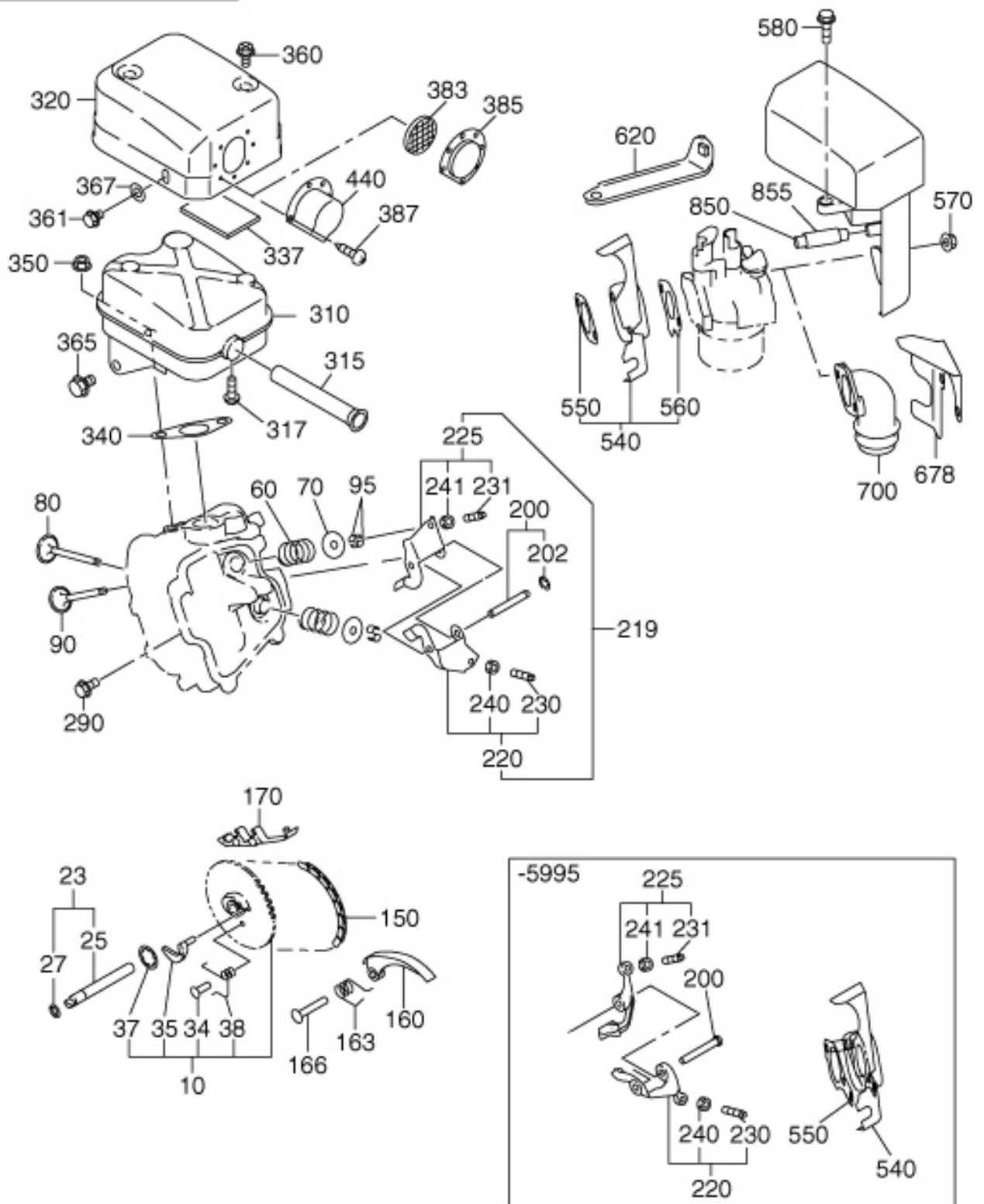
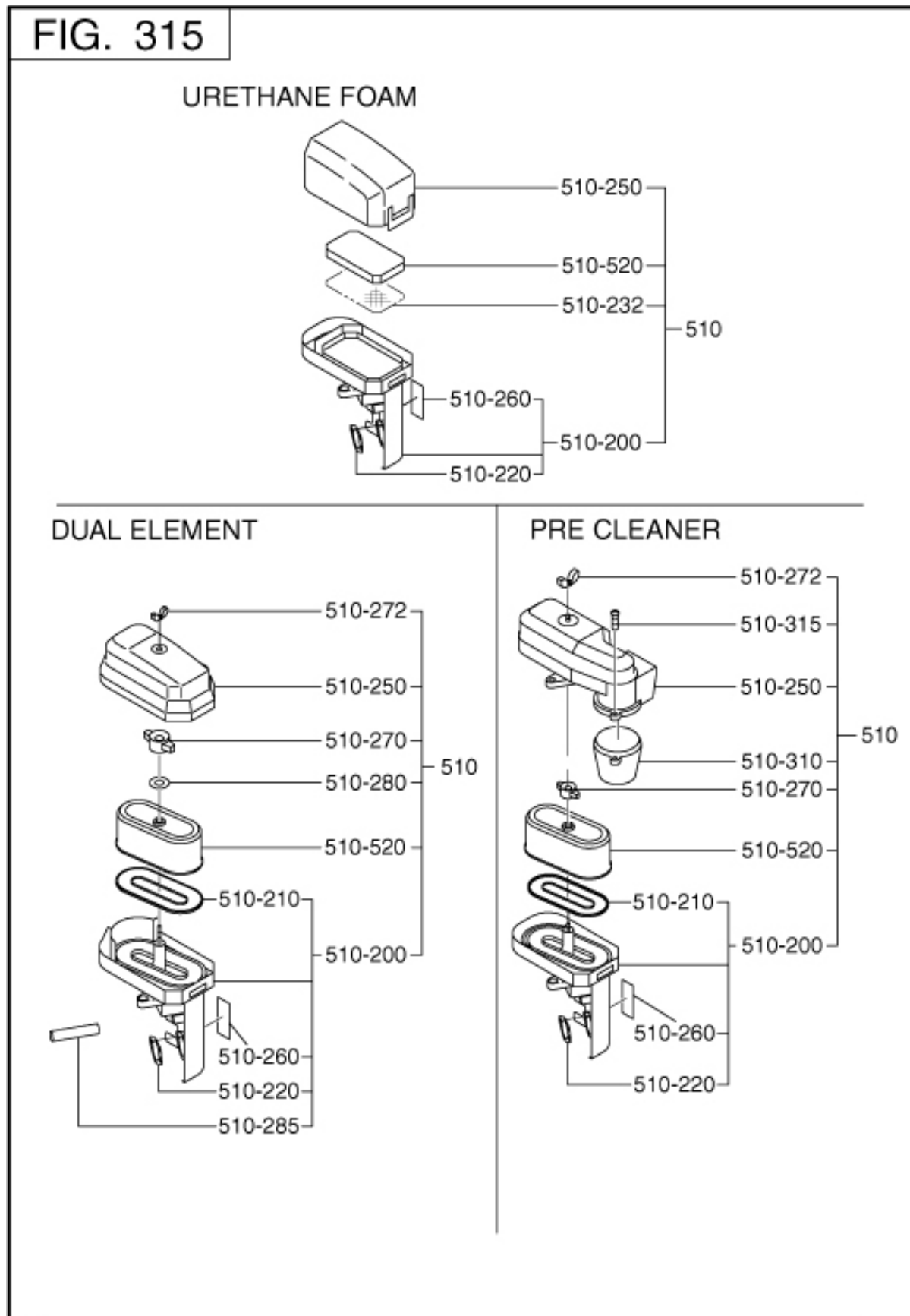

FIG. 300



3 インテーク,エクゾースト



REF	部品番号	部品名称	管理番号	数量	摘要	互換部品番号
510	277-32611-10	エアクリーナ AY	6666-	1	URETHANE FOAM	277-32611-20
	277-32611-00	エアクリーナ AY	-6665	1	URETHANE FOAM	277-32611-10
-200	277-32601-18	ベース CP	6666-	1		277-32601-28
-210	277-32610-08	パツキン	-6665	1		
-220	277-32604-08	パツキン	-	1		
-250	277-32602-08	カバー CP	-	1		277-32602-18
-260	277-32609-08	ラベル	-	1		
-520	277-32603-08	エレメント	-	1	URETHANE FOAM	

FIG. 400

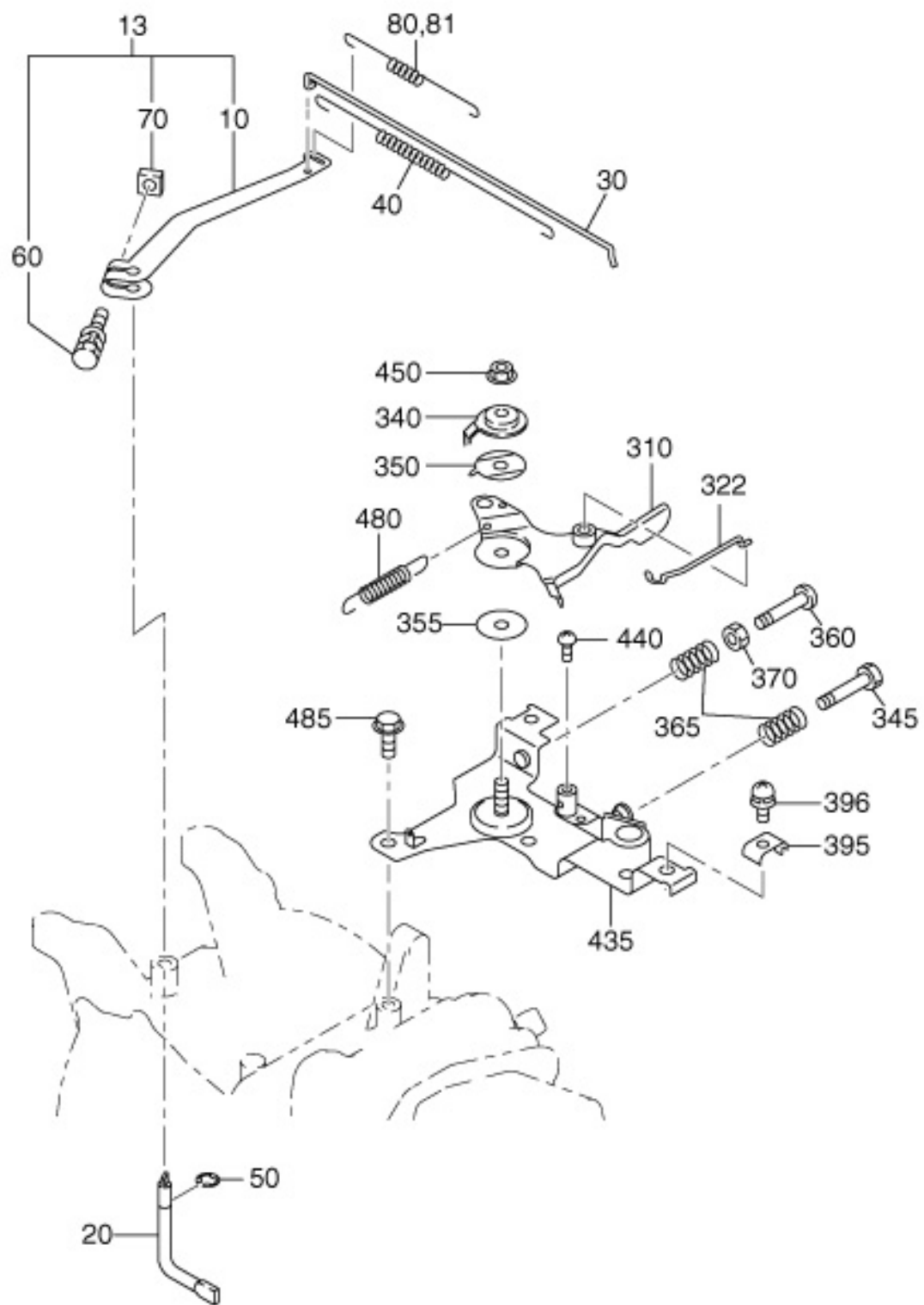

FIG. 500

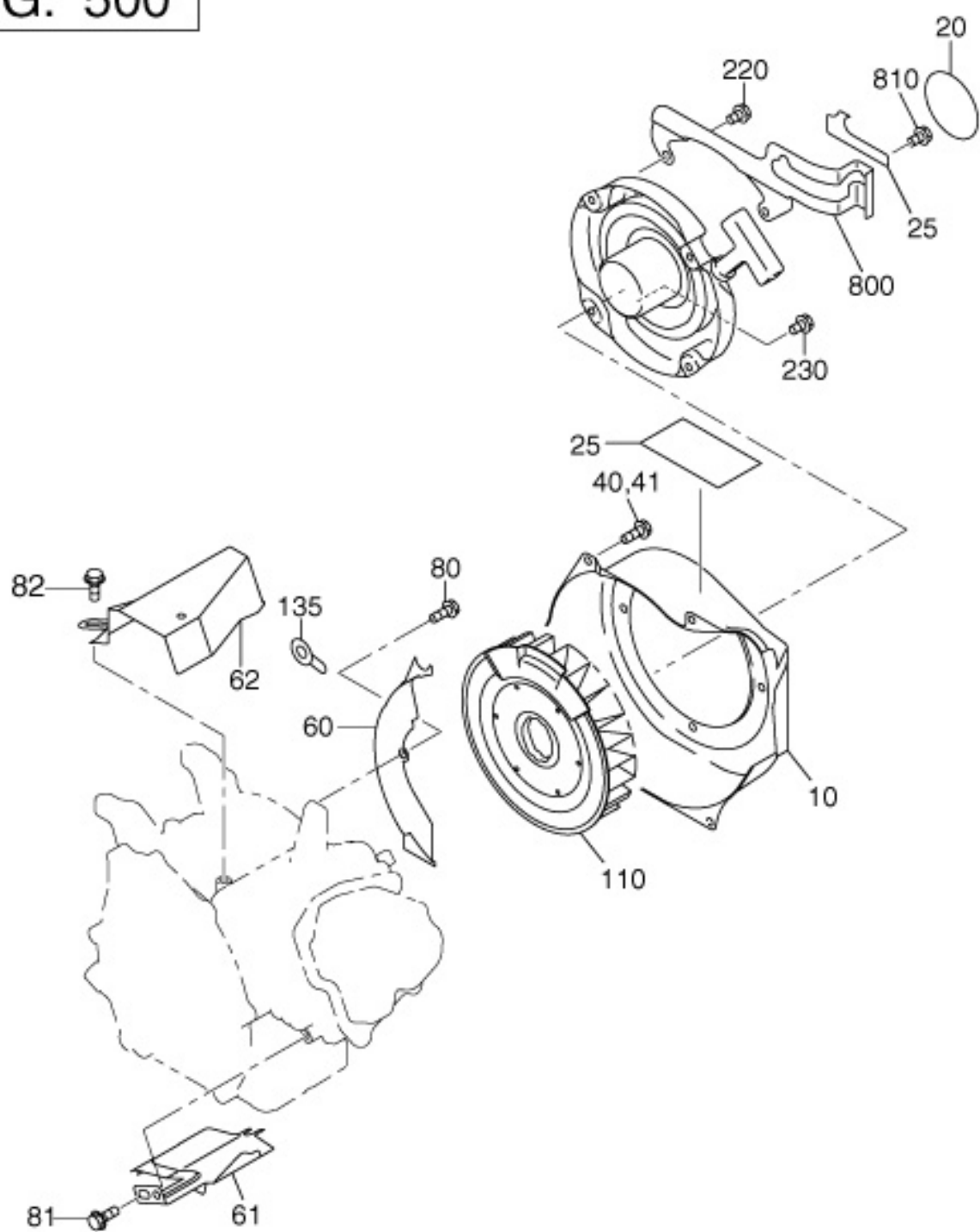
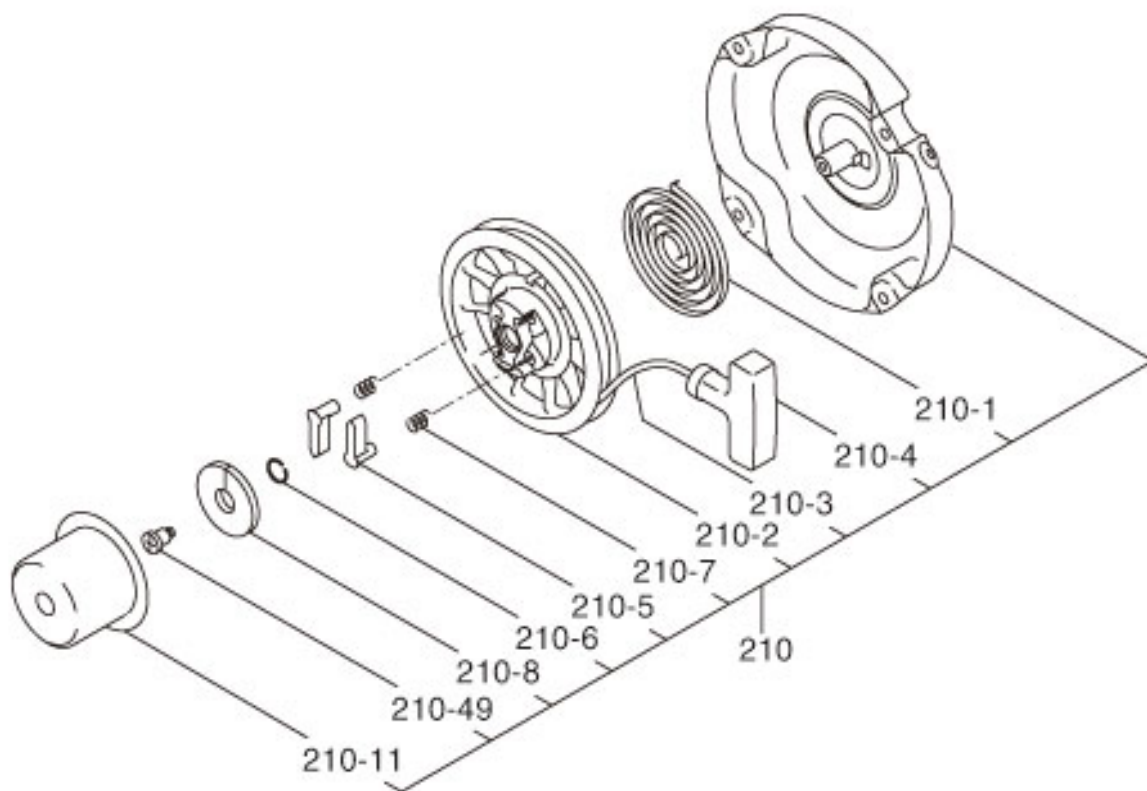

FIG. 520



RESIN

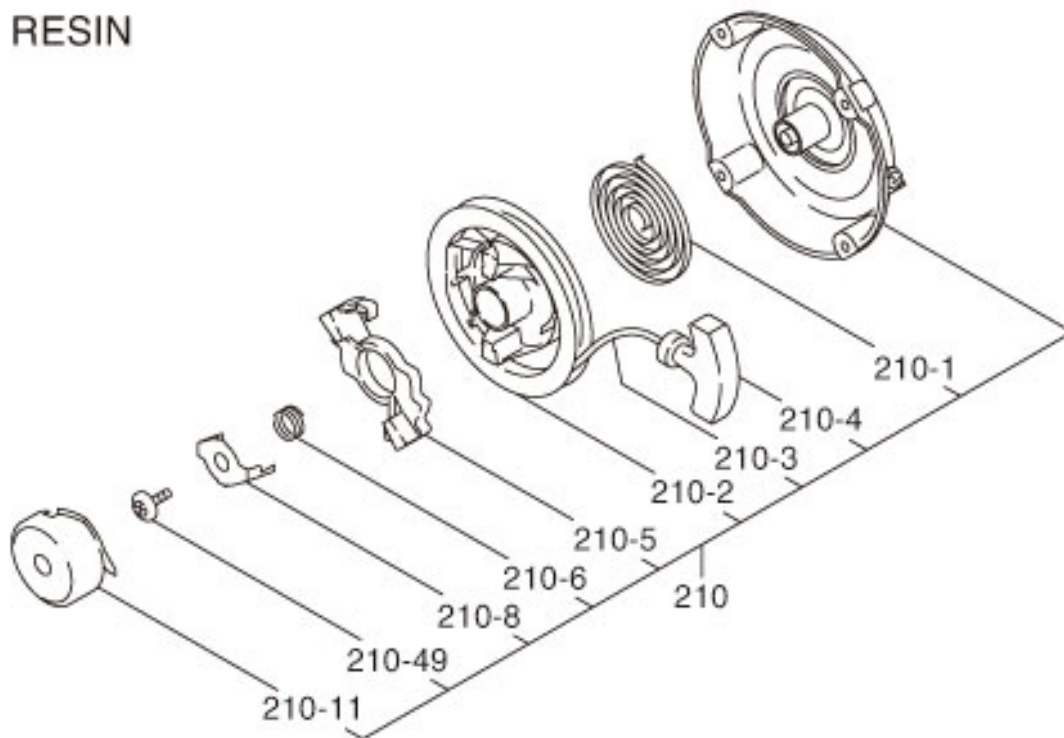

FIG. 600

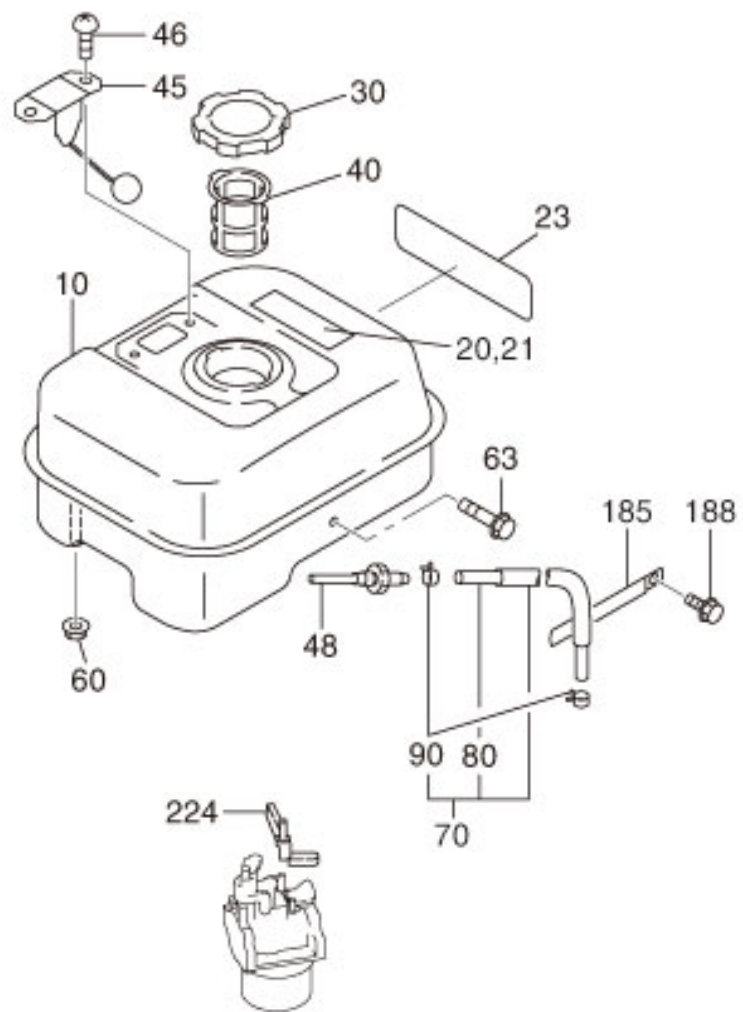

FIG. 640

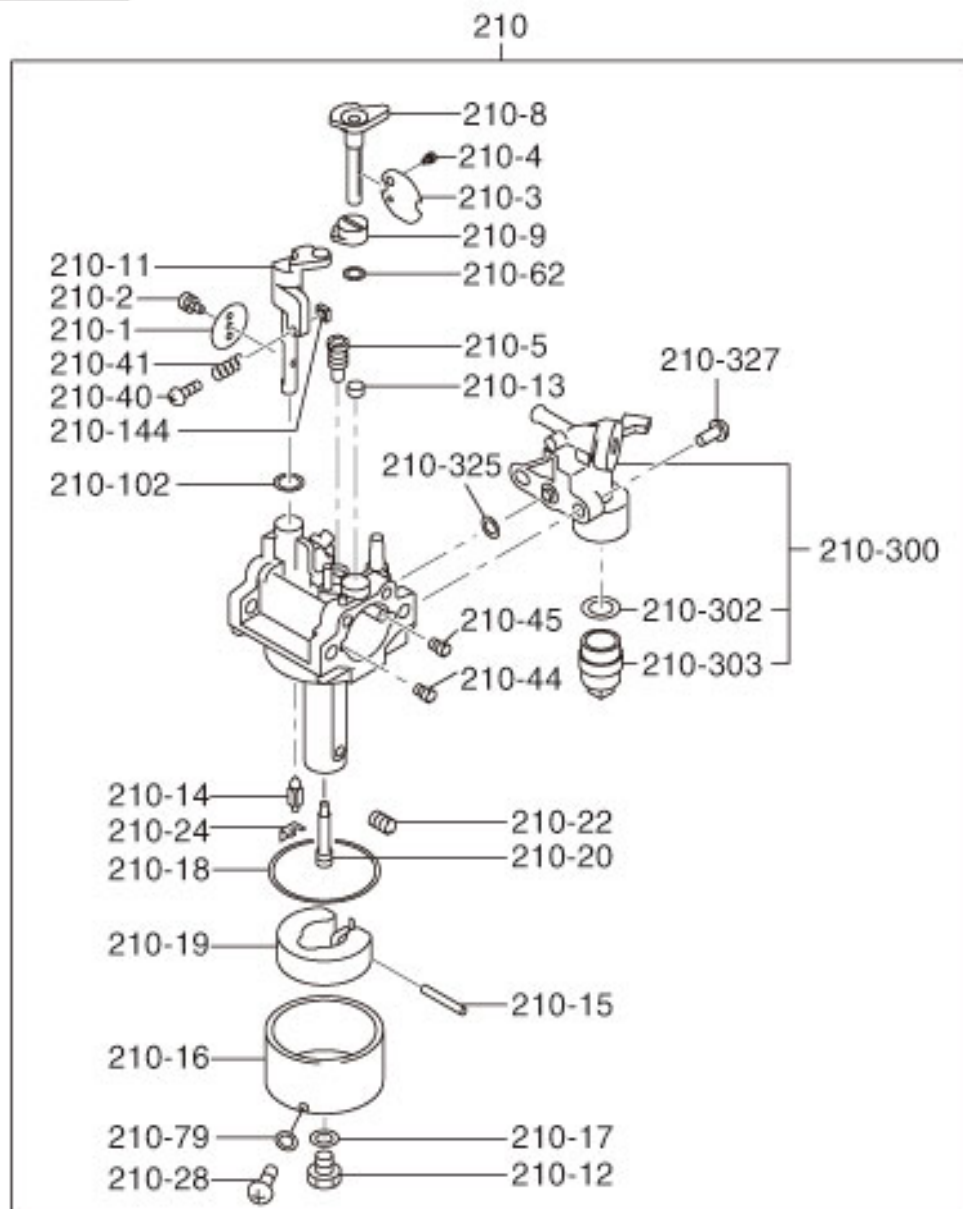

FIG. 700

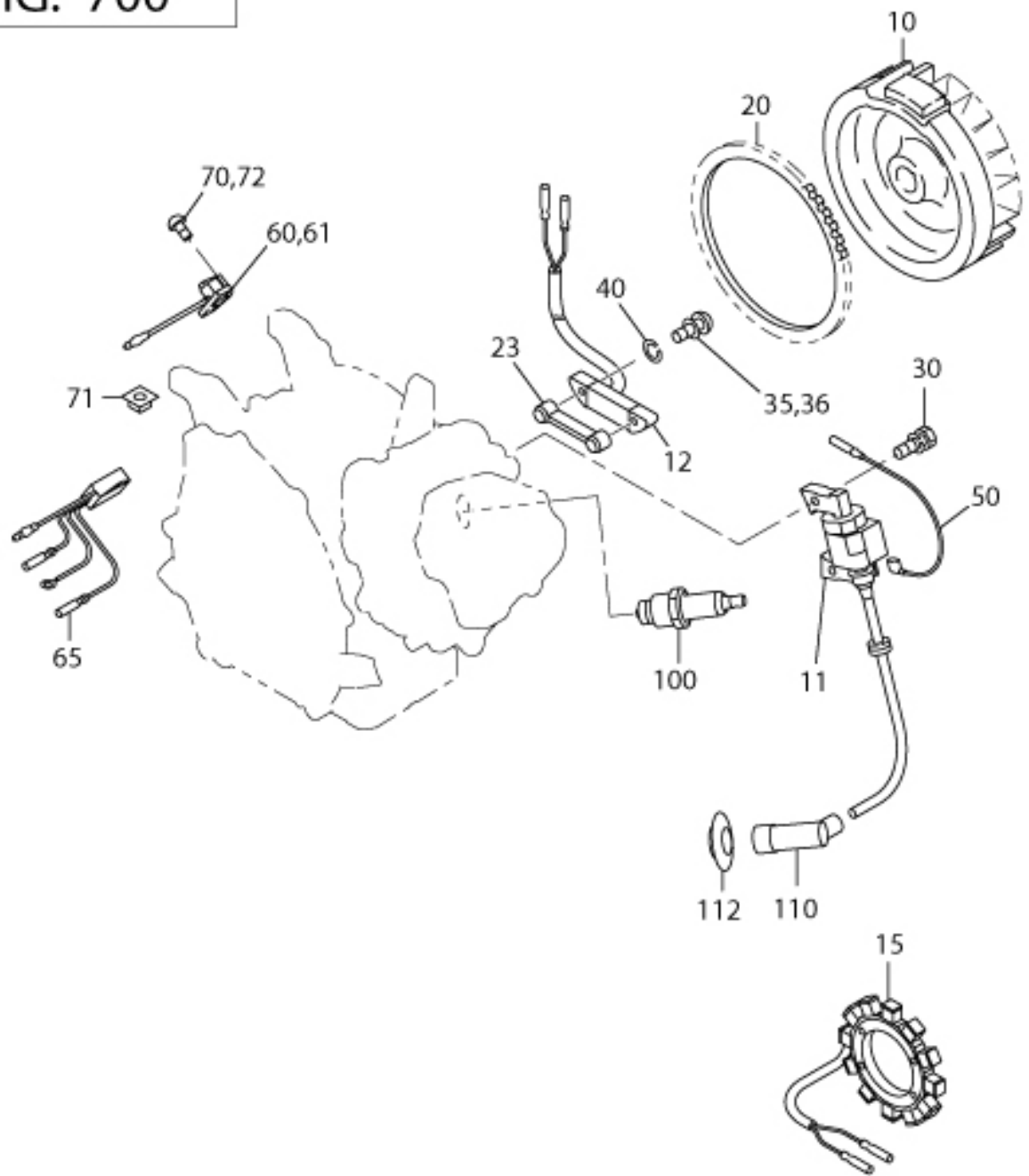

FIG. 720

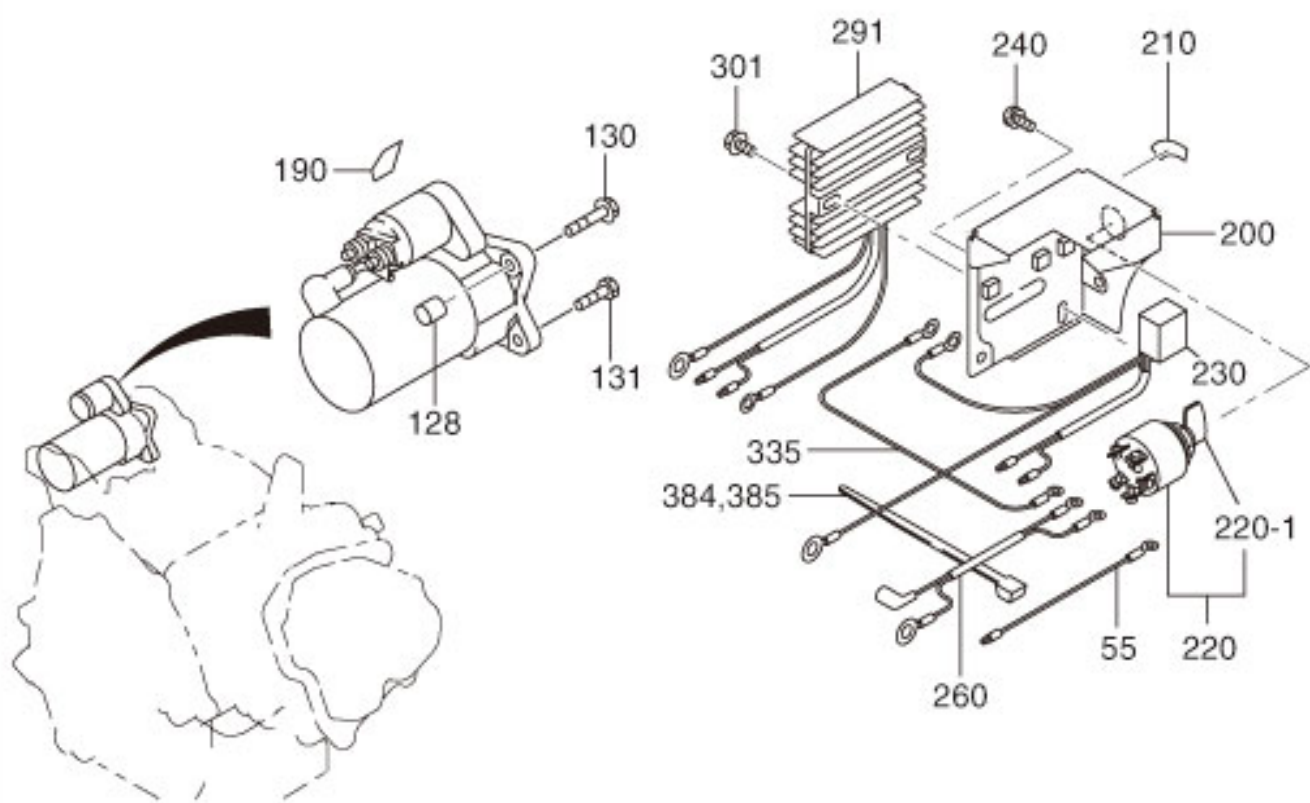

FIG. 730

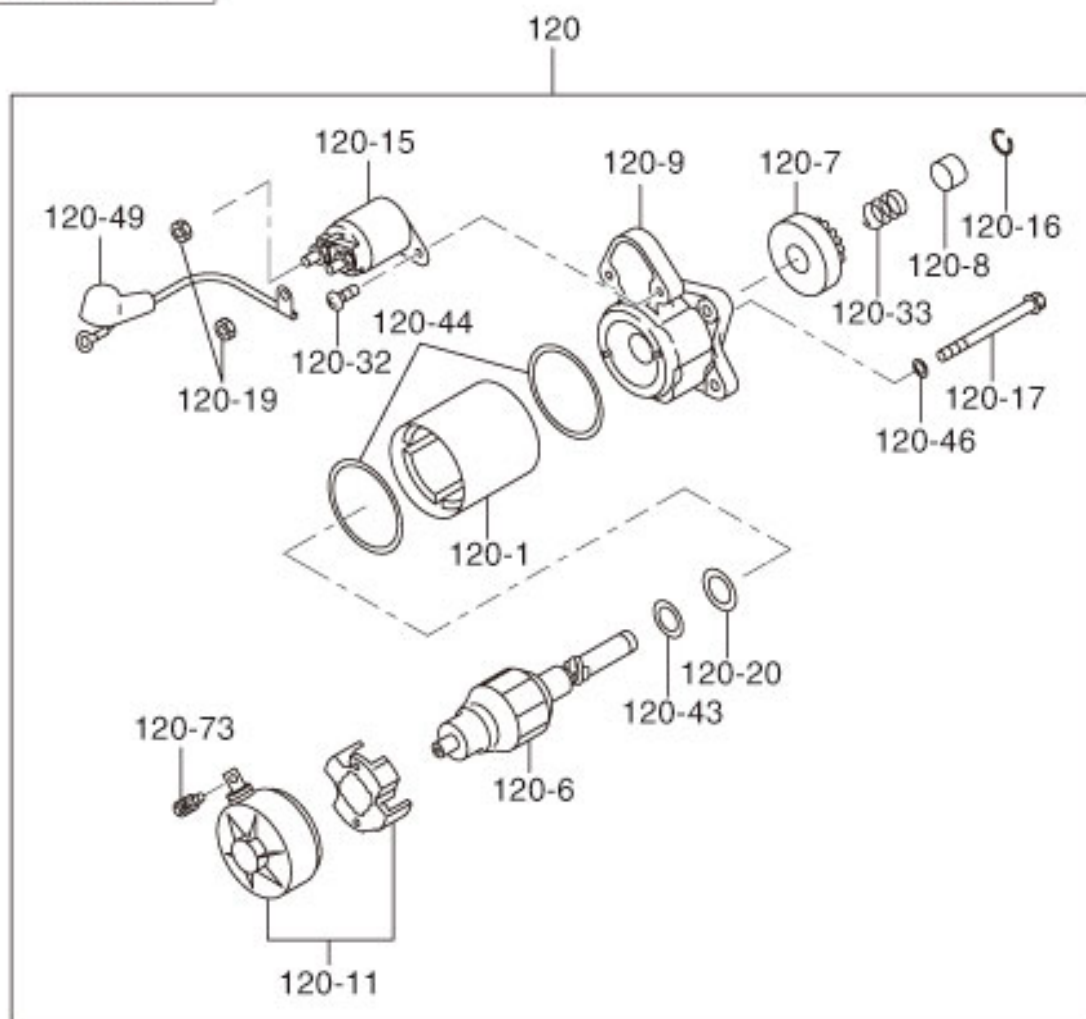

FIG. 900

