

3 5 7 0 4 5 0 A バケット ( 回転ダンプ ) BUCKET ( Slewing & Dumping )

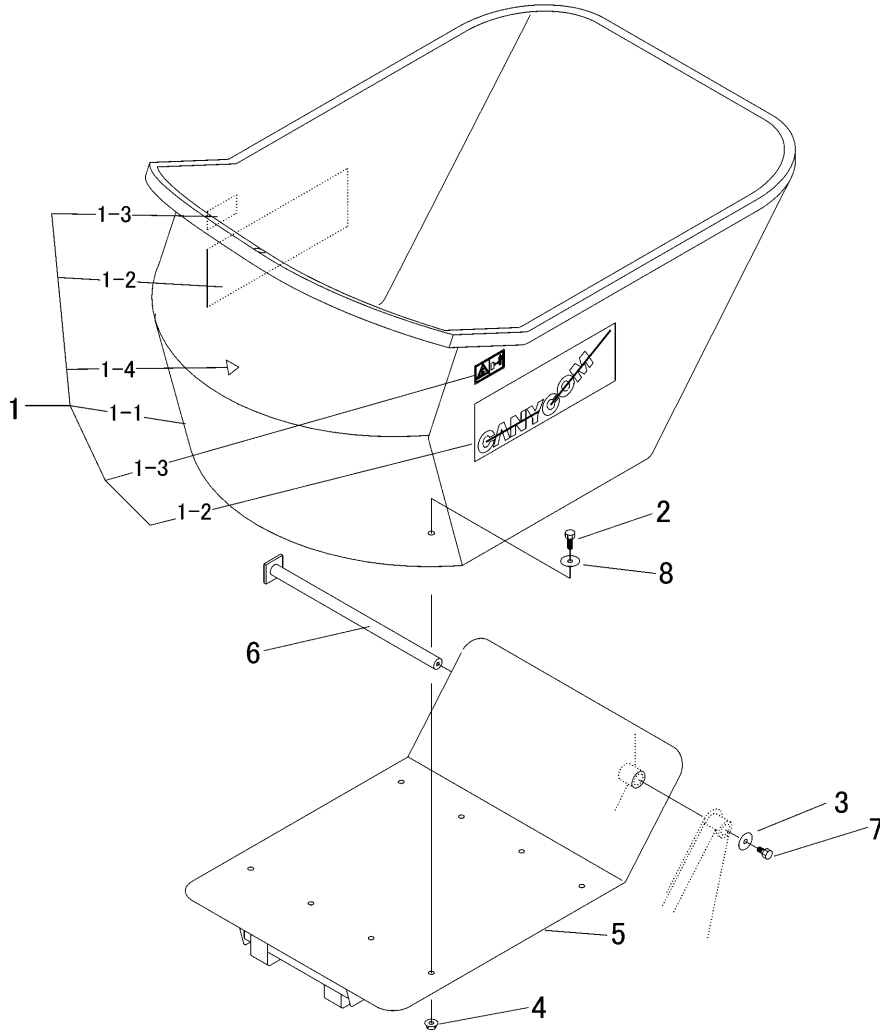

見出 NO.	部品番号 PART NO.	部品名称 PART NAME	個数 Q'ty	型 寸 DESCRIPTION	互 換 性 R/P	適 用 号 機 FROM ~ UP TO SERIAL NO.	備 考 REMARKS
1	3570 4501 100	ワゴンAssy	1	WAGON			
1-1	3570 4501 000	ワゴン	1	WAGON			
1-2	3670 5028 000	マーク	2	MARK			
1-3	3670 5114 000	マーク	2	MARK			
1-4	3661 5037 000	アイマーク	1	MARK			
2	A110 0510 040	ボルト	8	M10X40(SUS)			
3	0350 0561 040	PW	8	10×40×3.0(SUS)			
4	F301 0110 000	Fナット	8	M10			
5	3570 4505 000	フレーム	1	FRAME			
6	3570 4521 000	ピン	1	PIN			
7	K710 0110 020	Fボルト	1	M10X20			
8	0350 0161 040	PW	1	10×40×3.2			